

# The Conley index for fast-slow systems II: Multi-dimensional slow variable\*

Tomáš Gedeon<sup>†</sup>

Department of Mathematical Sciences  
Montana State University, Bozeman, MT 59717-0240, U.S.A.  
gedeon@math.montana.edu

Hiroshi Kokubu<sup>‡</sup>

Department of Mathematics  
Kyoto University, Kyoto 606-8502, Japan  
kokubu@math.kyoto-u.ac.jp

Konstantin Mischaikow

Center for Dynamical Systems and Nonlinear Studies  
School of Mathematics, Georgia Institute of Technology  
Atlanta, GA 30332, U.S.A.  
mishaik@math.gatech.edu

Hiroe Oka<sup>§</sup>

Department of Applied Mathematics and Informatics  
Faculty of Science and Technology  
Ryukoku University, Seta, Otsu 520-2194, Japan  
oka@rins.ryukoku.ac.jp

November 10, 2005

## Abstract

We use Conley index theory to develop a general method used to prove existence of periodic and heteroclinic orbits in a singularly perturbed system of ODE's. This is a continuation of the authors' earlier work [9] which

---

\*Supported by NSF Grant INT-0089631 and by JSPS Japan-U.S. Cooperative Science Program.

<sup>†</sup>Partially supported by NSF EIA-BITS grant 426411.

<sup>‡</sup>Partially supported by JSPS Grant-in-Aid for Scientific Research (No.14340055, 17340045), Ministry of Education, Science, Technology, Culture and Sports, Japan.

<sup>§</sup>Partially supported by JSPS Grant-in-Aid for Scientific Research (No.14540219, 17540206), Ministry of Education, Science, Technology, Culture and Sports, Japan.

is now extended to systems with multidimensional slow variables. The key new idea is the observation that the Conley index in fast-slow systems has a cohomological product structure. The factors in this product are slow index, which captures information about the flow in the slow direction transverse to the slow flow, and the fast index, which is analogous to the Conley index for fast-slow systems with one-dimensional slow flow [9].

**Key words:** Fast-slow system, periodic and heteroclinic orbits, Conley index

## 1 Introduction

Consider a family of differential equations on  $\mathbb{R}^n = \mathbb{R}^k \times \mathbb{R}^\ell$  given by

$$\dot{x} = f(x, y), \quad \dot{y} = \epsilon g(x, y), \quad (1.1)$$

where  $f : \mathbb{R}^k \times \mathbb{R}^\ell \rightarrow \mathbb{R}^k$  and  $g : \mathbb{R}^k \times \mathbb{R}^\ell \rightarrow \mathbb{R}^\ell$  are  $C^1$  and  $\epsilon \geq 0$ . Since  $\epsilon$  is assumed to be small there are effectively two time scales for this system. The fast dynamics is governed by  $\dot{x} = f(x, y)$  and the slow dynamics by  $\dot{y} = g(x, y)$  restricted to  $f(x, y) = 0$ . Concatenations of solutions of the fast and slow dynamics are called *singular solutions*. The mathematical challenge is to identify conditions for which there exists an  $\epsilon_0 > 0$  such that for all  $0 < \epsilon \leq \epsilon_0$  there are solutions to the full system (1.1) which lie near the singular solution.

Since these systems arise frequently in applications, problems of this nature have received considerable attention. A particularly powerful technique, called geometric singular perturbation theory, was developed by N. Fenichel, C. Jones and N. Kopell<sup>1</sup>. Based on extensions of the classical concepts of normal hyperbolicity and transversality, when applicable it provides sharp results.

Our goal is to develop an alternative approach, which we believe is more computable, using topological rather than geometrical methods. As will be explained in detail later, the ideas of the Conley index theory ([1, 3, 15, 19]) play a prominent role in this program; changes in the index substitute for transversality, and normal hyperbolicity is replaced by isolation. In an earlier paper [9], we developed a theory for fast-slow systems with a one dimensional slow variable ( $\ell = 1$ ). In this paper we go a step further and provide a method which is applicable to systems with a slow variable of arbitrary dimension, and from which one can conclude the existence of heteroclinic or periodic orbits. This requires a fundamentally new idea concerning the decomposition of the Conley index into slow and fast indices. In the vocabulary of the current paper, in the one dimensional slow manifold case, the Conley index consists only of the fast index. We hasten to add that we are not claiming credit for the idea of using topological tools in singular perturbation problems. In fact, we will include some isolated elements of the history of the approach not only to put the results

---

<sup>1</sup>The reader is referred to [1] for a survey and further references on the geometric perturbation theory. The closest analogy to the material of this paper is the exchange lemma introduced in [11].

of this paper into its proper context, but also to provide a reference for some of the more abstract ideas that are introduced here.

With this in mind, let us begin by introducing some of the fundamental ideas from the index theory. Consider for the moment an arbitrary flow  $\gamma : \mathbb{R} \times X \rightarrow X$  defined on  $X$ , a locally compact metric space. A compact set  $N \subset X$  is called an *isolating neighborhood* if

$$\text{Inv}(N, \gamma) := \{x \in X \mid \gamma(\mathbb{R}, x) \subset N\} \subset \text{int}N$$

where  $\text{int}N$  denotes the interior of  $N$ . If  $S = \text{Inv}(N, \gamma)$  for some isolating neighborhood  $N$ , then  $S$  is referred to as an *isolated invariant set*. The Conley index is an index of isolating neighborhoods with the property that if  $\text{Inv}(N, \gamma) = \text{Inv}(N', \gamma)$ , then the Conley index of  $N$  equals the Conley index of  $N'$ . In this way, one may also view the Conley index as an index of isolated invariant sets.

To compute the Conley index requires the existence of an index pair. To be more precise, let  $S$  be an isolated invariant set. A pair of compact sets

$(N, L)$  with  $L \subset N$  is an *index pair* for  $S$  if:

- (1)  $S = \text{Inv}(\text{cl}(N \setminus L))$  and  $N \setminus L$  is a neighborhood of  $S$ ;
- (2)  $L$  is positively invariant in  $N$ , i.e. given  $x \in L$  and  $\gamma([0, t], x) \subset N$  then  $\gamma([0, t], x) \subset L$ ;
- (3)  $L$  is an exit set for  $N$ , i.e. given  $x \in N$  and  $T > 0$  such that  $\gamma(T, x) \notin N$ , there is a  $t \in [0, T]$  such that  $\gamma([0, t], x) \subset N$  and  $\gamma(t, x) \in L$ .

The cohomological Conley index of  $S$  is given in terms of the relative Alexander-Spanier cohomology of the index pair; that is,

$$CH^*(S) := \bar{H}^*(N, L).$$

Given an isolating neighborhood, its Conley index carries some information on the dynamics of the associated isolated invariant set. In our case we will make use of theorems in which the cohomological Conley index guarantees the existence of periodic orbits ([14, Theorem 1.3]) and heteroclinic orbits ([1, Theorem 3.3.1]).

Returning to the context of fast-slow systems, for fixed  $\epsilon \geq 0$ , the solutions to system (1.1) generate a flow

$$\varphi^\epsilon : \mathbb{R} \times \mathbb{R}^n \rightarrow \mathbb{R}^n.$$

In the special case  $\epsilon = 0$ , (1.1) has a simpler form, since  $y$  becomes a constant, and hence, can be viewed as a parameter for the flows on  $\mathbb{R}^k$ . Namely, for each  $y \in \mathbb{R}^\ell$ , there exists a flow  $\psi_y : \mathbb{R} \times \mathbb{R}^k \rightarrow \mathbb{R}^k$  given by

$$(\psi_y(t, x), y) = \varphi^0(t, x, y). \tag{1.2}$$

For a fixed bounded region  $Y \subset \mathbb{R}^\ell$ , the *parameterized flow*

$$\psi_Y : \mathbb{R} \times \mathbb{R}^k \times Y \rightarrow \mathbb{R}^k \times Y$$

is defined by  $\psi_Y(t, x, y) := (\psi_y(t, x), y)$  for  $y \in Y$ .

Another way to simplify (1.1) is to first rescale time by  $\tau = \epsilon t$  and then in the new equations let  $\epsilon = 0$ :

$$0 = f(x, y), \quad \dot{y} = g(x, y). \quad (1.3)$$

The set of points  $(x, y) \in \mathbb{R}^{k+\ell}$  with  $f(x, y) = 0$  is called a *slow manifold* of the problem (1.1). If  $\frac{\partial f}{\partial x}$  is invertible for  $y$  in some bounded set  $Y$ , then by the implicit function theorem, there is a function  $x = m(y)$  such that  $f(m(y), y) = 0$ . The set  $M := \{(x, y) \in \mathbb{R}^{k+\ell} \mid x = m(y), y \in Y\}$  denotes a branch of the slow manifold over  $Y$ . Solutions of

$$\dot{y} = g(m(y), y)$$

determine the slow flow  $\varphi_M^{\text{slow}} : \mathbb{R} \times M \rightarrow M$ . If the branch  $M$  is clear from the context, the slow flow is denoted by  $\varphi^{\text{slow}}(y, t)$ .

**Example 1.1** As an extremely simple example that begins to suggest the philosophy behind our approach consider the fast-slow system

$$\dot{r} = r(1 - r), \quad \dot{\theta} = \epsilon \quad (1.4)$$

presented in polar coordinates which for each fixed value of  $\epsilon > 0$  generates a flow  $\varphi^\epsilon : \mathbb{R} \times \mathbb{R}^2 \rightarrow \mathbb{R}^2$ . For  $\epsilon = 0$ ,  $\theta$  can be viewed as a parameter, leading to the family of flows  $\psi_\theta : \mathbb{R} \times [0, \infty) \rightarrow [0, \infty)$ . Clearly, the slow manifold is given by  $M = \{(r, \theta) \mid r = 1\}$ . Observe that  $M$  becomes a periodic orbit for  $\epsilon > 0$ .

Turning now to the language of the Conley index, the sets

$$N = \{(r, \theta) \mid \frac{1}{2} \leq r \leq \frac{3}{2}\} \quad \text{and} \quad L = \{(r, \theta) \mid r = \frac{1}{2} \text{ or } r = \frac{3}{2}\}$$

define an index pair for all values of  $\epsilon \geq 0$ . A simple direct calculation shows that

$$CH^k(\text{Inv}(N, \varphi^\epsilon); \mathbb{Z}_2) \cong \begin{cases} \mathbb{Z}_2 & \text{if } k = 1, 2 \\ 0 & \text{otherwise,} \end{cases}$$

for all  $\epsilon \geq 0$ . This combined with the fact that for  $\epsilon > 0$  there exists a Poincaré section for  $N$  allows us to apply [14, Theorem 1.3] to prove that  $\text{Inv}(N, \varphi^\epsilon)$  contains a periodic orbit for all  $\epsilon > 0$ .

While all the information in the previous paragraph is correct, it fails to indicate how the theory is used in the context of a fast-slow system. Thus we repeat the calculations beginning with information that naturally arises from the singular flow  $\varphi^0$ . Consider a point  $K = (1, \theta_0) \in M$ . For the flow  $\psi_{\theta_0}$ ,

$$N(\theta_0) = \{r \mid \frac{1}{2} \leq r \leq \frac{3}{2}\} \quad \text{and} \quad L(\theta_0) = \{r \mid r = \frac{1}{2} \text{ or } r = \frac{3}{2}\}$$

is an index pair for  $K$ . Furthermore,

$$CH^k(K; \mathbb{Z}_2) \cong \begin{cases} \mathbb{Z}_2 & \text{if } k = 1 \\ 0 & \text{otherwise.} \end{cases}$$

Observe that the isolating neighborhood  $N$  is the product of the slow manifold  $M$  and an isolating neighborhood for a point on the slow manifold under the fast flow. More generally, we can describe  $N$  as a disk bundle with base consisting of the slow manifold where the dynamics on each fiber is determined by the fast flow. In particular, we can apply the Thom isomorphism theorem [20] to conclude that

$$CH^*(\text{Inv}(N, \varphi^\epsilon); \mathbb{Z}_2) \cong CH^*(K; \mathbb{Z}_2) \smile \bar{H}^*(M, \mathbb{Z}_2) \quad (1.5)$$

where  $\smile$  denotes the cup product. Observe that we have computed the Conley index of  $\text{Inv}(N, \varphi^\epsilon)$  using the fast dynamics at a single point on the slow manifold and the global topology of the slow manifold.

To obtain the existence of a Poincaré section, we use the slow flow  $\dot{\theta} = 1$  restricted to  $M$ . As was indicated earlier this provides us with sufficient information to conclude the existence of a periodic orbit in  $\text{Inv}(N, \varphi^\epsilon)$ .

This type of computation of the Conley index from the perturbation of a normally hyperbolic slow manifold can be found in [5]. However, it is quite common for the slow manifolds of (1.1) to be unbounded. In particular, this means that given a compact set  $N$  which intersects the slow manifold,  $\text{Inv}(N, \varphi^0) \cap \partial N \neq \emptyset$ . In other words, unlike the example of (1.4) an isolating neighborhood and, hence, an index pair cannot be obtained for the singular flow  $\varphi^0$ . Conley [4] resolved the first part of this problem by providing a characterization of a *singular isolating neighborhood*; that is, a compact neighborhood which is an isolating neighborhood for  $\varphi^\epsilon$  for all sufficiently small  $\epsilon > 0$ . The latter issue was addressed by Mrozek, Reineck and the third author with a description [16, Theorem 1.15] of a *singular index pair*; that is, a pair of sets  $(N, L)$  such that

$$CH^*(\text{Inv}(\text{cl}(N \setminus L)), \varphi^\epsilon) \cong H^*(N, L)$$

for all sufficiently small  $\epsilon > 0$ .

**Example 1.2** While the above mentioned results provide the foundations upon which this work is based they do not, in themselves, possess sufficient computational power. To see this consider the question of the existence of periodic travelling waves to a system of reaction diffusion equations of the form

$$\begin{aligned} \epsilon u_t &= \epsilon^2 u_{xx} + uf(u, v) \\ v_t &= v_{xx} + vg(u, v) \end{aligned} \quad (1.6)$$

where  $u$  and  $v$  are population densities of a prey and a predator species and  $\epsilon > 0$  but small. It is assumed that

$$\frac{\partial f}{\partial v} < 0 \quad \text{and} \quad \frac{\partial g}{\partial u} > 0$$

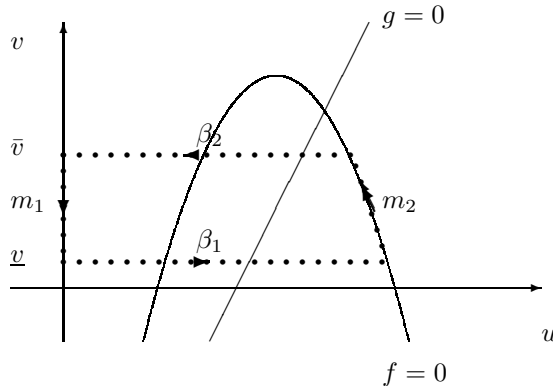

Figure 1: Zero sets for the functions  $f$  and  $g$ . The dotted curve and arrows indicate the location and direction of the singular periodic orbit whose existence was demonstrated in [8]. The  $v$ -axis and the right branch of  $f = 0$  are branches of the slow manifolds  $M_1$  and  $M_2$ , respectively. The singular orbits on the branches of the slow manifold are labeled by  $m_i \subset M_i$ . The connecting orbits  $\beta_1$  and  $\beta_2$  are the heteroclinic orbits defined by the fast flow that belong to the singular orbit.

and that the zero sets of  $f$  and  $g$  are as indicated in Figure 1. This system was investigated by Gardner and Smoller [8] using Conley index techniques and, in part, motivated the work of this paper.

Choosing the travelling wave coordinate  $\xi = (x - \theta t)/\epsilon$ , (1.6) reduces to the fast-slow system

$$\begin{aligned}
 \dot{u} &= w \\
 \dot{w} &= -\theta w - uf(u, v) \\
 \dot{v} &= \epsilon z \\
 \dot{z} &= -\epsilon(\theta z + vg(u, v))
 \end{aligned} \tag{1.7}$$

Clearly, both the fast and slow variables are two dimensional and thus it is impossible to capture the dynamics in a single drawing. However, Figure 1 indicates the projection onto the  $u$  and  $v$  coordinates of the periodic orbit whose existence was shown in [8]. This orbit is obtained as the concatenation of four orbits, two from the fast system (the horizontal dotted lines) denoted by  $\beta_i$ ,  $i = 1, 2$ , and two from the slow system (the vertical dotted lines) denoted by  $m_1$  and  $m_2$ . In particular, the horizontal dotted lines are projections of the connecting orbits indicated in Figure 2.

Our construction of the singular isolating neighborhood is similar in spirit to that of [8]. The major difference arises from the way the Conley index of the associated isolating neighborhood is computed. In [8] the computation is performed by the construction of a homotopy to the van der Pol equation. This

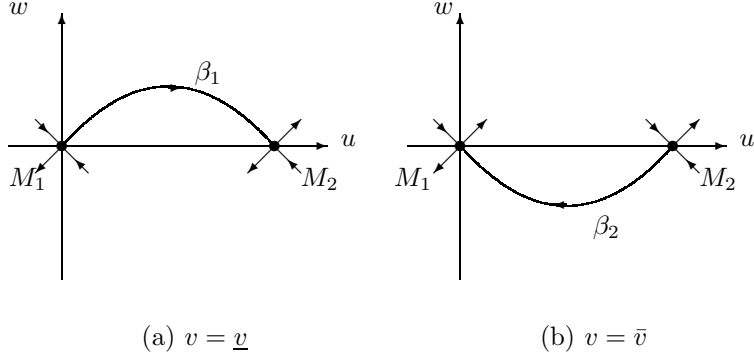

Figure 2: Connecting orbit in the fast dynamics at  $v = \underline{v}$  and  $v = \bar{v}$ . Observe that in both cases the two equilibria lie on the slow manifolds  $M_1$  and  $M_2$ .

makes specific use both of the equation under consideration and of the orbit being investigated. In contrast we provide a direct means of computing the index similar in spirit to that of Example 1.1.

To be more precise, Examples 1.2 and 1.1 are obviously different in that the singular orbit of the first consists of both segments from the slow manifold and orbits from the fast dynamics. Therefore it is impossible to construct an isolating neighborhood that can be viewed as a vector bundle with fibers defined in terms of the fast dynamics and the base consisting of a subset of the slow manifold. This observation motivates the following more general concept.

**Definition 1.3** A pair of compact sets  $(N, L)$  with a continuous surjection  $p : N \rightarrow A$  forms an *index bundle* over the base space  $A$ , if there exists an open covering  $\{U\}$  of  $A$ , such that, for any  $a \in A$  and an element  $U_a$  of the cover containing  $a$ , the inclusion map

$$j_{U_a} : (N(a), L(a)) \rightarrow (N(U_a), L(U_a))$$

induces an isomorphism

$$j_{U_a}^* : H^*(N(U_a), L(U_a)) \rightarrow H^*(N(a), L(a)), \quad (1.8)$$

where  $N(a) = p^{-1}(a)$ ,  $N(U) = p^{-1}(U)$  and  $L(a) = L \cap N(a)$ .

The construction of these bundles occupies much of this paper. The base of the bundle will be defined in terms of the singular orbit on the slow manifold. Furthermore, for each fiber the key information is  $H^*(N(a), L(a))$  which is meant to suggest that we are keeping track of the Conley index information derived from the fast flow at a point on the slow manifold. As will become clear our construction of an index depends only on the dynamics near the singular orbit. In fact it is constructed by combining local information from the segments of the solutions to the slow and fast dynamics.

The fact that we only need the dynamics in the neighborhood of the singular orbit to perform the computations allows us to consider finite coverings of the neighborhood. For a particular example of (1.7) it can be shown using a numerically rigorous computation that another singular periodic orbit which shares the segments  $\beta_1$  and  $\beta_2$  exists. Using covering space arguments we can concatenate these singular orbits and construct associated index bundles. This allows us to directly conclude the existence of a full two shift of bounded solutions where the symbols correspond to the two simplest singular periodic orbits [10].

Our construction of index bundles requires considerable notation. As an aid to the reader we have adopted the following convention. Capital bold letters denote neighborhoods in  $\mathbb{R}^k \times \mathbb{R}^\ell$  while capital calligraphed letters indicate the corresponding subsets obtained by projecting onto  $\mathbb{R}^\ell$ . More precisely, let  $\Pi : \mathbb{R}^k \times \mathbb{R}^\ell \rightarrow \mathbb{R}^\ell$  denote the canonical projection map, then for  $\mathbf{U} \subset \mathbb{R}^k \times \mathbb{R}^\ell$ ,  $\mathcal{U} := \Pi(\mathbf{U})$ . The strategy of this paper is to first construct an abstract theory of index bundles from which the Conley index can be computed and then to prove that under a general set of hypotheses an index bundle for a fast-slow system can be constructed. We will indicate sets of the first type by adding a circle and the latter type by adding a dagger; that is,  $\dagger\mathbf{U}$  indicates a set in  $\mathbb{R}^k \times \mathbb{R}^\ell$  that is constructed from a given fast slow system, whereas  $\circ\mathbf{U}$  denotes the corresponding set in an abstract index bundle.

To obtain an index bundle for a system such as (1.7) requires two ingredients:

- (1) we need to be able to construct the sets  $\dagger\mathbf{N}$  and  $\dagger\mathbf{L}$ , and
- (2) we need to be able to identify the Conley indices of the elements on different branches of the slow manifold that are connected by heteroclinic orbits of the fast dynamics.

We now provide an outline of the key ingredients to these steps with the details being provided in the sections that follow.

The construction of  $\dagger\mathbf{N}$  over a branch of the slow manifold  $M$  is in some sense the easiest. We begin with the following concept.

**Definition 1.4** Let  $\Sigma$  be an  $(\ell - 1)$ -dimensional disc which is a local section for a slow flow  $\varphi^{\text{slow}}$  on a slow manifold  $M$ . A *slow sheet* is a normally hyperbolic subset  $E \subset M$  defined by

$$E := \bigcup_{z \in \Sigma} \varphi^{\text{slow}}([0, T(z)], z)$$

where  $T : \Sigma \rightarrow (0, \infty)$  is a bounded continuous function.

**Remark 1.5** The requirement that  $E$  is normally hyperbolic seemingly contradicts our philosophy that our assumptions should be topological rather than geometrical. The assumptions that we need are slightly weaker. We need to assume that the slow manifold is a manifold and the Conley index in the normal



direction to the slow manifold is that of a hyperbolic fixed point. More precisely, we need to assume, for the fast-slow system (1.1) that the derivative  $D_x f(x, y)$  is non-singular, which by the Implicit Function Theorem guarantees existence of a slow manifold  $x = h(y)$ , and the and that for each  $y$  the fixed point  $x = h(y)$  of the fast flow has the Conley index of a hyperbolic fixed point. Since we do not know at this point of any application where this weaker assumption can be verified without normal hyperbolicity, we chose to simplify the exposition by assuming normal hyperbolicity.

In practice the slow sheet contains the segment of the singular orbit that lies on the slow manifold. For technical reasons, the slow sheets may be too large and thus, as is described in Section 5, we choose  $U \subset E$ . To produce a neighborhood in  $\mathbb{R}^k \times \mathbb{R}^\ell$  define the *tube*

$$\dagger\mathbf{U} := [-r, r]^k \times U$$

where  $0 < r \ll 1$ .

Sets of this form define  $\dagger\mathbf{N}$  in the region of the segments that lie on the slow manifold. Of course we also need to identify  $\dagger\mathbf{L}_{\dagger\mathbf{U}} = \dagger\mathbf{L} \cap \dagger\mathbf{U}$ , the associated subsets of  $\dagger\mathbf{L}$ . As will be made clear shortly, this is more subtle.

Clearly, the next step is to construct neighborhoods that contain the heteroclinic orbits of the fast flow that join the singular segments in the slow flow. However, the existence of the heteroclinic orbits is not in itself sufficient. What is necessary is that these fast orbits carry the index information from one tube to the next. We check for this additional information by means of the *topological transition matrix* (see [12, 13]) which is described below.

Let  $S$  be an isolated invariant set. A pair of disjoint compact invariant subsets  $(M(1), M(2))$  form an *attractor repeller pair decomposition* of  $S$  if for every  $x \in S \setminus (M(1) \cup M(2))$ , the alpha and omega limit sets of  $x$  are contained in  $M(2)$  and  $M(1)$ , respectively.<sup>2</sup>

In the context of a parameterized flow  $\psi_Y : \mathbb{R} \times \mathbb{R}^k \times Y \rightarrow \mathbb{R}^k \times Y$ , an attractor repeller pair *continues over*  $Y$ , if there is an isolated invariant set  $S = \text{Inv}(N, \psi_Y)$  with an attractor repeller pair decomposition  $(M(1), M(2))$ . It is fairly easy to show that attractors and repellers are isolated invariant sets. Observe that if one defines

$$S_y := S \cap (\mathbb{R}^k \times \{y\}),$$

then  $S_y$  is an isolated invariant set for  $\psi_y$ . Similarly,  $(M_y(1), M_y(2))$  is an attractor repeller pair decomposition for  $S_y$ .

Since  $S$  is an isolated invariant set for  $\psi_Y$ , there exists an index pair  $(N, L)$  and  $CH^*(S) = \bar{H}^*(N, L)$ . It can be checked that  $(N_y, L_y)$  is an index pair for  $S_y$ . Furthermore, the continuation theory of the Conley index guarantees that for

---

<sup>2</sup>An attractor repeller pair decomposition is a special case of a Morse decomposition [3]. We have chosen to present the material of the paper in the setting of an attractor repeller for the sake of notational simplicity. The results extend in the obvious way to arbitrary Morse decompositions.

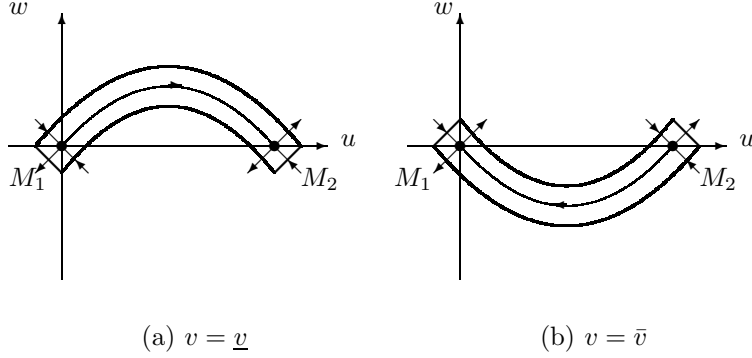

Figure 3: Boxes that contain the Connecting orbit in the fast dynamics at  $v = \underline{v}$  and  $v = \bar{v}$ . For  $v \approx \underline{v}$ ,  $(M_1, M_0)$  is an attractor-repeller pair while  $(M_0, M_1)$  is an attractor-repeller pair for  $v \approx \bar{v}$

all  $y \in Y$  the inclusion map  $j_y : (N_y, L_y) \rightarrow (N, L)$  induces an isomorphism  $j_y^* : H^*(N, L) \rightarrow H^*(N_y, L_y)$ . The same result applies to attractors and repellers.

Let us return for a moment to (1.7). Fix  $y = (v, z)$  and consider an isolating neighborhood  $N$  for the fast flow  $\psi_y$  for which  $M_y(1)$  and  $M_y(2)$  form an attractor repeller pair. An easy computation shows that the dimension of the unstable manifolds of these equilibria are the same. Thus one expects that for a typical point  $y \in Y$ , there is no connecting orbit between  $M_y(1)$  and  $M_y(2)$ . Stated differently

$$\text{Inv}(N, \psi_y) = \bigcup_{p=1,2} M_y(p).$$

Now consider  $Y$  and an isolating neighborhood  $N$  such that  $M(1)$  and  $M(2)$  form an attractor-repeller pair for  $\text{Inv}(N, \psi_Y)$  and choose  $y_0, y_1 \in Y$  such that

$$\text{Inv}(N, \psi_{y_i}) = \bigcup_{p=1,2} M_{y_i}(p), \quad i = 0, 1.$$

In this case there exists a topological transition matrix from  $y_0$  to  $y_1$  which is a lower triangular, degree zero isomorphism

$$T_{y_0, y_1}^* : CH^*(M_{y_1}(1)) \oplus CH^*(M_{y_1}(2)) \rightarrow CH^*(M_{y_0}(1)) \oplus CH^*(M_{y_0}(2))$$

If the  $(2, 1)$  off-diagonal entry of  $T_{y_1, y_0}^*$  is non-zero, then for any continuous curve  $y = y(\lambda)$ ,  $\lambda \in [0, 1]$  with  $y(0) = y_0$  and  $y(1) = y_1$  in the parameter space, there is a  $\lambda \in [0, 1]$  such that, for the parameter value  $y(\lambda)$ , there exists a heteroclinic orbit from  $M_{y(\lambda)}(2)$  and  $M_{y(\lambda)}(1)$ .

We codify this discussion into the context of the fast-slow systems via the following definition.

**Definition 1.6** A set  $\dagger\mathbf{B} \subset \mathbb{R}^k \times \mathbb{R}^\ell$  is a *box*, if the following conditions are satisfied:

- (1)  $\dagger\mathbf{B}$  is an isolating neighborhood for the parameterized flow  $\psi_{\dagger\mathcal{B}}$  defined by

$$\begin{aligned} \psi_{\dagger\mathcal{B}} : \mathbb{R} \times \mathbb{R}^k \times \dagger\mathcal{B} &\rightarrow \mathbb{R}^k \times \dagger\mathcal{B} \\ (t, x, y) &\mapsto (\psi_y(t, x), y), \end{aligned}$$

where  $\dagger\mathcal{B} := \Pi(\dagger\mathbf{B})$ .

- (2) Let  $S(\dagger\mathbf{B}) := \text{Inv}(\dagger\mathbf{B}, \psi_{\dagger\mathcal{B}})$ . There exists an attractor-repeller decomposition

$$\mathcal{M}(S(\dagger\mathbf{B})) := \{M(p, \dagger\mathbf{B}) \mid p = 1, 2 \ (2 > 1)\}.$$

- (3) There are isolating neighborhoods  $V(p, \dagger\mathbf{B})$  for  $M(p, \dagger\mathbf{B})$ ,  $p = 1, 2$ , such that

$$V(p, \dagger\mathbf{B}) \subset \text{int } \dagger\mathbf{B} \quad \text{and} \quad V(1, \dagger\mathbf{B}) \cap V(2, \dagger\mathbf{B}) = \emptyset.$$

- (4) Let  $\dagger\mathbf{B}_y = \dagger\mathbf{B} \cap (\mathbb{R}^k \times \{y\})$ ,  $S_y(\dagger\mathbf{B}) := \text{Inv}(\dagger\mathbf{B}_y, \psi_y)$  and let  $\{M_y(p, \dagger\mathbf{B}) \mid p = 1, 2\}$  be the corresponding attractor-repeller decomposition of  $S_y(\dagger\mathbf{B})$ . There are subsets  $\dagger\mathcal{B}^0$  and  $\dagger\mathcal{B}^1$  open relative to the subset topology on  $\dagger\mathcal{B}$  such that for fixed  $i = 0, 1$  the invariant sets  $S_y(\dagger\mathbf{B})$  are related by continuation for all  $y \in \dagger\mathcal{B}^i$ .

- (5) For each  $y \in \dagger\mathcal{B}$ , the set  $\dagger\mathbf{B}_y$  is a  $k$ -dimensional disc.

Notice that Definition 1.6(4) implies that there are no heteroclinic orbits between the Morse sets at the parameter values  $y \in \dagger\mathcal{B}^0 \cup \dagger\mathcal{B}^1$ . By the construction, the sets  $S_{y_0}(\dagger\mathbf{B})$ ,  $y_0 \in \dagger\mathcal{B}^0$  and  $S_{y_1}(\dagger\mathbf{B})$ ,  $y_1 \in \dagger\mathcal{B}^1$  are related by continuation. It follows that a topological transition matrix

$$\begin{aligned} T_{y_0, y_1}^* : CH^*(M_{y_1}(1, \dagger\mathbf{B})) \oplus CH^*(M_{y_1}(2, \dagger\mathbf{B})) \\ \rightarrow CH^*(M_{y_0}(1, \dagger\mathbf{B})) \oplus CH^*(M_{y_0}(2, \dagger\mathbf{B})) \end{aligned}$$

is defined for every  $y_0 \in \dagger\mathcal{B}^0$  and  $y_1 \in \dagger\mathcal{B}^1$ . We note that by the continuation argument, topological transition matrices between  $y_0$  and  $y'_0 \in \dagger\mathcal{B}^0$  or between  $y_1$  and  $y'_1 \in \dagger\mathcal{B}^1$  are identity maps, therefore,  $T_{y_0, y_1}^*$  does not depend on the choice of  $y_0 \in \dagger\mathcal{B}^0$  and  $y_1 \in \dagger\mathcal{B}^1$ , hence may be denoted by  $T_{\dagger\mathbf{B}}^*$ .

Let us return to the setting of Example 1.2. Let  $\dagger\mathbf{U}_i$  and  $\dagger\mathbf{B}_i$  denote the tube and box containing  $m_i$  and  $\beta_i$ , respectively, and set

$$\dagger\mathbf{N} = \bigcup_{i=1}^2 \dagger\mathbf{U}_i \cup \bigcup_{i=1}^2 \dagger\mathbf{B}_i.$$

As was indicated earlier, the proof of the existence of a periodic orbit depends upon the construction of an index bundle  $(\dagger\mathbf{N}, \dagger\mathbf{L})$ . This requires the construction of an appropriate singular exit set  $\dagger\mathbf{L}$  which, as will be explained shortly,

is a nontrivial task. For the moment observe that since the singular isolating neighborhood is constructed using tubes and boxes it is reasonable to assume that they must intersect in an appropriate manner. This intersection is measured in  $\mathbb{R}^\ell$ , the space of slow variables, that is, the compatibility of tubes and boxes involves conditions expressed on the intersections  $\dagger\mathcal{U}_1 \cap \dagger\mathcal{B}_1 \cap \dagger\mathcal{U}_2$  and  $\dagger\mathcal{U}_2 \cap \dagger\mathcal{B}_2 \cap \dagger\mathcal{U}_1$ . This is made precise in Definition 5.3 where the notion of a *periodic corridor* involving  $I$  boxes  $\{\dagger\mathbf{B}_i \mid i = 1, \dots, I\}$  is introduced.

Now consider sequential tubes  $\dagger\mathbf{U}_i$  and  $\dagger\mathbf{U}_{i+1}$  in the periodic corridor joined by the box  $\dagger\mathbf{B}_i$ . In Section 5 we prove three essential results. The first is that  $\dagger\mathbf{N}$  is a singular isolating neighborhood. The second is that a slight modification allows one to verify that  $(\dagger\mathbf{N}, \dagger\mathbf{L})$ , where construction of  $\dagger\mathbf{L}$  is described below, is a singular index pair. The third is that if

$$T_{\dagger\mathbf{B}_i}^*(2, 1) : CH^*(M_{y_{i+1}}(1, \dagger\mathbf{B}_i)) \rightarrow CH^*(M_{y_i}(2, \dagger\mathbf{B}_i))$$

is non-zero for every  $i = 1, \dots, I$ , then,  $(\dagger\mathbf{N}, \dagger\mathbf{L})$  is an index bundle with a projection onto the slow segments of the singular orbit. This allows us to compute  $H^*(\dagger\mathbf{N}, \dagger\mathbf{L})$  and prove the following theorem.

**Theorem 1.7** *Consider the fast-slow system (1.1) and a periodic corridor containing boxes  $\{\dagger\mathbf{B}_i\}_{i=1, \dots, I}$ . If  $T_{\dagger\mathbf{B}_i}^*(2, 1)$  is an isomorphism for all  $i = 1, \dots, I$ , then for sufficiently small  $\epsilon > 0$ , there exists a periodic solution to (1.1).*

To explain the difficulty in constructing  $\dagger\mathbf{L}$  consider the simpler setting where the slow variable is 1-dimensional. Given a periodic corridor the transition matrix information provides sufficient information to demonstrate the existence of a periodic orbit [9, Theorem 1.6]. A heuristic description of this result is as follows. Given a tube  $\dagger\mathbf{U}_i$  in the periodic corridor,  $\dagger\mathcal{U}_i = \Pi(\dagger\mathbf{U}_i)$  is an interval. For each point  $m \in M \cap \dagger\mathbf{U}_i$ , let  $y = \Pi(m) \in \dagger\mathcal{U}_i$ . Using the fast flow  $\psi_y$  we can construct an index pair  $(\dagger\mathbf{N}_y, \dagger\mathbf{L}_y^{\text{fast}})$ . The continuation theory of the Conley index guarantees that for all  $y \in \dagger\mathcal{U}_i$  the inclusion map  $j_{\dagger\mathcal{U}_i} : (\dagger\mathbf{N}_y, \dagger\mathbf{L}_y^{\text{fast}}) \rightarrow (\dagger\mathbf{N}_{\dagger\mathcal{U}_i}, \dagger\mathbf{L}_{\dagger\mathcal{U}_i}^{\text{fast}})$  induces an isomorphism  $j_{\dagger\mathcal{U}_i}^* : H^*(\dagger\mathbf{N}_{\dagger\mathcal{U}_i}, \dagger\mathbf{L}_{\dagger\mathcal{U}_i}^{\text{fast}}) \rightarrow H^*(\dagger\mathbf{N}_y, \dagger\mathbf{L}_y^{\text{fast}})$ . Now consider sequential tubes  $\dagger\mathbf{U}_i$  and  $\dagger\mathbf{U}_{i+1}$  in the periodic corridor joined by the box  $\dagger\mathbf{B}_i$ . If

$$T_{\dagger\mathbf{B}_i}^*(2, 1) : CH^*(M_{y_{i+1}}(1, \dagger\mathbf{B}_i)) \rightarrow CH^*(M_{y_i}(2, \dagger\mathbf{B}_i))$$

is non-zero, then we have an isomorphism from  $H^*(\dagger\mathbf{N}_{y_{i+1}}, \dagger\mathbf{L}_{y_{i+1}}^{\text{fast}})$  to  $H^*(\dagger\mathbf{N}_{y_i}, \dagger\mathbf{L}_{y_i}^{\text{fast}})$ .

This observation leads to the conclusion that  $(\dagger\mathbf{N}, \dagger\mathbf{L}^{\text{fast}})$  is an index bundle with projection  $\Pi : \dagger\mathbf{N} \rightarrow \cup_{i=1}^I \dagger\mathcal{U}_i$ .

In the previous example the singular exit set is essentially defined by the expanding directions of the fast flow. This is not the case for higher dimensional slow manifolds, since there is no natural expansion or contraction rate around typical orbits. In fact the tubes were constructed using flow boxes which explicitly eliminates any sense of expansion or contraction. The expanding and contracting dimensions in the slow dynamics must be determined globally, but

matched locally via the fast dynamics within the box. We resolve this dichotomy in Section 2 by introducing the notion of local models (Definition 2.2) and their compatibility (Definition 2.3). In Section 3 these local models are used to construct a slow index bundle  $(\circ\mathbf{N}, \circ\mathbf{L}^{\text{slow}})$  and a fast index bundle  $(\circ\mathbf{N}, \circ\mathbf{L}^{\text{fast}})$ . These are then combined to create the total index bundle  $(\circ\mathbf{N}, \circ\mathbf{L})$ . Finally, in Section 4 the cohomology of the total index bundle is computed. It should be remarked that these are abstract constructions. In Section 5 we show that given a specific fast slow system for which the compatibility conditions can be checked, the pair  $(\dagger\mathbf{N}, \dagger\mathbf{L})$  defines an index bundle from which the index can be computed for all sufficiently small  $\epsilon > 0$

The techniques developed in this paper can also be applied to proving the existence of connecting orbits. To be more precise consider an example where the slow flow exhibits isolated invariant sets on different branches. There are two obvious questions. First, do the invariant sets for the slow flow persist as invariant sets for  $\varphi^\epsilon$  for sufficiently small  $\epsilon > 0$ , and if so does there exist a connecting orbit from one to the other? The first question was addressed by Conley and Fife [5]. A minor modification of the above mentioned techniques can be used to answer the second question.

As in the periodic case the basic building blocks are tubes and boxes though we need to include one other concept to capture the isolated invariant sets of the slow dynamics.

**Definition 1.8** A subset  $C$  of a slow manifold  $M$  is a *cap*, if it is an isolating block under the slow flow  $\varphi^{\text{slow}}$  on  $M$ .

Using caps it is easy to modify the definition of a periodic corridor to obtain a *heteroclinic corridor* (see Definition 5.4). In particular, a heteroclinic corridor contains a repelling cap  $C_R$  and an attracting cap  $C_A$ . Let

$$\dagger\mathbf{C}_R := [-r, r]^k \times C_R \quad \text{and} \quad \dagger\mathbf{C}_A := [-r, r]^k \times C_A.$$

In Section 5 the proof of the following result is provided.

**Theorem 1.9** *Consider the fast-slow system (1.1) and a heteroclinic corridor containing boxes  $\{\dagger\mathbf{B}_i\}_{i=1, \dots, I}$ . If  $T_{\dagger\mathbf{B}_i}^*(2, 1) \neq 0$  for all  $i = 1, \dots, I$ , then for all sufficiently small  $\epsilon, r > 0$ , there exists a connecting orbit from  $\text{Inv}(\dagger\mathbf{C}_R, \varphi^\epsilon)$  to  $\text{Inv}(\dagger\mathbf{C}_A, \varphi^\epsilon)$ .*

The outline of the rest of this paper is as follows. As is indicated earlier, in Section 2, we define abstractly *local models* and their compatibility conditions. The notion of compatible local model isolates conditions under which the cohomology  $H^*(\circ\mathbf{N}, \circ\mathbf{L})$  has a product structure. In Section 3, we exhibit this product structure using the notion of an index bundle. We compute the cohomology of an index bundle using a version of Leray-Hirsh Theorem in Section 4. In Section 5, we define the periodic and heteroclinic corridors, show how to build from them a singular isolating neighborhood  $\dagger\mathbf{N}$  and the exit set  $\dagger\mathbf{L}$ , and

furthermore, we show how  $(\dagger\mathbf{N}, \dagger\mathbf{L})$  can be decomposed to form a collection of compatible local models, thus allowing us to compute  $\bar{H}^*(\dagger\mathbf{N}, \dagger\mathbf{L})$ . We postpone the proofs of several results from this section to Appendix B. In Appendix A, we provide some background in the Conley index theory.

## 2 Local and global models

In this section we introduce the notion of a local model and its compatibility. A collection of compatible local models gives an ideal model for computing the index of a singular index pair. Once a singular index pair is identified as described in Section 5, one obtains a collection of compatible local models which facilitates the index computation, with the aid of the notion of index bundle which will be introduced in Section 3.

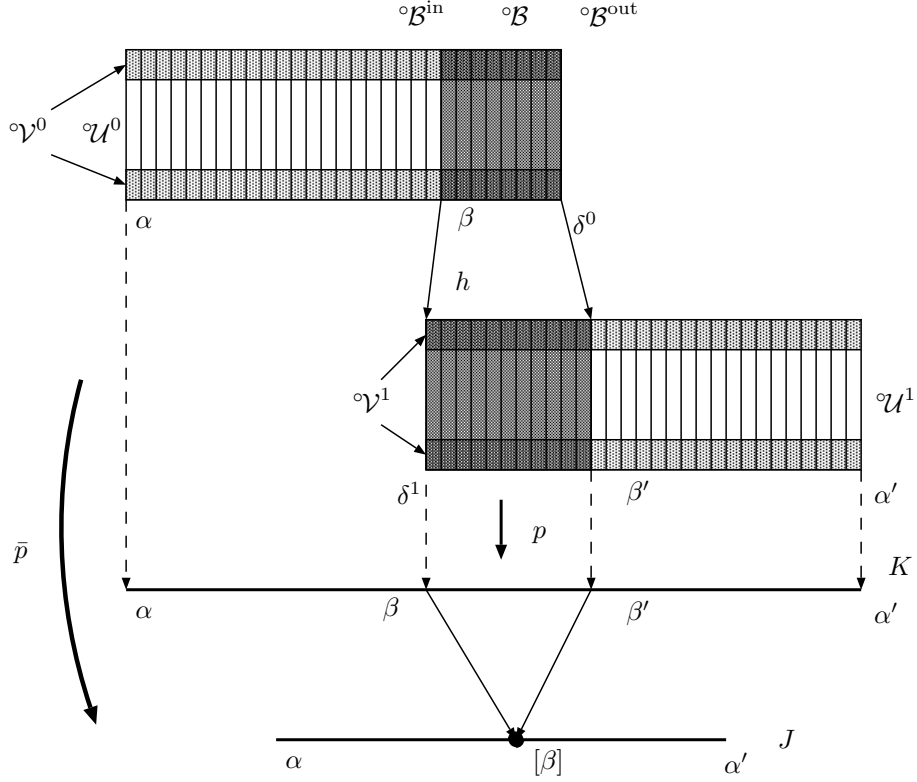

Figure 4: Slow local model.

**Definition 2.1** A *slow local model*  $(\mathcal{U}^0, \mathcal{U}^1, \mathcal{V}^0, \mathcal{V}^1, \mathcal{B}, h, p)$  consists of a collection of compact subsets  $(\mathcal{U}^0, \mathcal{U}^1, \mathcal{V}^0, \mathcal{V}^1, \mathcal{B})$  in  $\mathbb{R}^\ell$  together with a map

$h : \circ\mathcal{B} \rightarrow \circ\mathcal{B}'$  and a fibration  $p : \circ\mathcal{U}^0 \rightarrow K$ ,  $\circ\mathcal{B}'$  and  $K$  being defined below, that satisfy the following properties:

- (1)  $\circ\mathcal{V}^j \subset \circ\mathcal{U}^j$  for  $j = 0, 1$ .
- (2)  $\circ\mathcal{B} \subset \circ\mathcal{U}^0$  and there is a set  $\circ\mathcal{B}' \subset \circ\mathcal{U}^1$  which is homeomorphic to  $\circ\mathcal{B}$  under a map  $h : \circ\mathcal{B} \rightarrow \circ\mathcal{B}'$  that satisfies  $h(\circ\mathcal{B} \cap \circ\mathcal{V}^0) = \circ\mathcal{B}' \cap \circ\mathcal{V}^1$ . Let  $\circ\mathcal{U}$  be the union of  $\circ\mathcal{U}^0$  and  $\circ\mathcal{U}^1$  with  $\circ\mathcal{B}$  and  $\circ\mathcal{B}'$  identified by the homeomorphism  $h$ . Similarly, let  $\circ\mathcal{V}$  be the union of  $\circ\mathcal{V}^0$  and  $\circ\mathcal{V}^1$  with the same identification by  $h$ .
- (3) There exist fibrations  $p_0 : \circ\mathcal{U}^0 \rightarrow [\alpha, \delta^0]$  and  $p_1 : \circ\mathcal{U}^1 \rightarrow [\delta^1, \alpha']$  such that  $\circ\mathcal{B}' = p_1^{-1}([\delta^1, \beta'])$  for some  $\beta' \in (\delta^1, \alpha')$  and  $\circ\mathcal{B} = p_0^{-1}([\beta, \delta^0])$  for some  $\beta \in (\alpha, \delta^0)$ . Let  $\circ\mathcal{B}^{\text{in}} = p_0^{-1}(\beta)$  and  $\circ\mathcal{B}^{\text{out}} = p_1^{-1}(\beta')$ .
- (4) There exists a homeomorphism  $\pi : [\beta, \delta^0] \rightarrow [\delta^1, \beta']$  such that  $p_1 \circ h = \pi \circ p_0$ . The map  $\pi$  induces a fibration  $p : \circ\mathcal{U} \rightarrow K$ , where  $K = [\alpha, \alpha']$  is given by identifying  $[\alpha, \delta^0]$  and  $[\delta^1, \alpha']$  under the map  $\pi$ . Let  $J$  be given by further collapsing the interval in  $K$  that corresponds to  $[\beta, \delta^0]$  for  $p_0$  (or equivalently  $[\delta^1, \beta']$  for  $p_1$ ) to a point, which will be denoted by  $[\beta]$ , and  $\bar{p} : \circ\mathcal{U} \rightarrow J$  be the resulting fibration. Observe that the fiber  $\bar{p}^{-1}([\beta])$  is  $\circ\mathcal{B}$  (or equivalently  $\circ\mathcal{B}'$ ).
- (5) For each  $\lambda \in K$ , a pair  $(\circ\mathcal{U}(\lambda), \circ\mathcal{V}(\lambda))$  given by

$$\circ\mathcal{U}(\lambda) = \circ\mathcal{U} \cap p^{-1}(\lambda), \quad \circ\mathcal{V}(\lambda) = \circ\mathcal{V} \cap p^{-1}(\lambda)$$

in a fiber is assumed to be homeomorphic to any other such pair  $(\circ\mathcal{U}(\mu), \circ\mathcal{V}(\mu))$  for  $\mu \in K$ .

**Definition 2.2** A local model  $(\circ\mathcal{U}^0, \circ\mathcal{U}^1, \circ\mathcal{V}^0, \circ\mathcal{V}^1, \circ\mathbf{U}^0, \circ\mathbf{U}^1, \circ\mathbf{B}, \circ\mathbf{L}, q)$  associated to a given slow local model  $(\circ\mathcal{U}^0, \circ\mathcal{U}^1, \circ\mathcal{V}^0, \circ\mathcal{V}^1, \circ\mathcal{B}, h, p)$  on  $\mathbb{R}^\ell$  consists of a collection of subsets  $(\circ\mathcal{U}^0, \circ\mathcal{U}^1, \circ\mathcal{V}^0, \circ\mathcal{V}^1, \circ\mathbf{U}^0, \circ\mathbf{U}^1, \circ\mathbf{B}, \circ\mathbf{L})$  in  $\mathbb{R}^n$  and a map  $q : \circ\mathbf{U}^0 \cup \circ\mathbf{B} \cup \circ\mathbf{U}^1 \rightarrow \circ\mathcal{U}$  that satisfy the following properties:

- (1)  $\circ\mathcal{V}^j \subset \circ\mathcal{U}^j \subset \circ\mathbf{U}^j \subset \mathbb{R}^{k+\ell}$  for  $j = 0, 1$ .
- (2) The map  $q$  is a fibration with a fiber homeomorphic to the  $k$ -disc ( $k = n - \ell$ ), such that  $q(\circ\mathbf{U}^0 \cup \circ\mathbf{B}) = \circ\mathcal{U}^0$ ,  $q(\circ\mathbf{B} \cup \circ\mathbf{U}^1) = \circ\mathcal{U}^1$ , and  $q(\circ\mathbf{B}) = \circ\mathcal{B}$ . Assume also that, for each  $j = 0, 1$ , the map  $q$  restricted to  $\circ\mathcal{U}^j$  is a homeomorphism onto  $\circ\mathcal{U}^j$  with  $q(\circ\mathcal{V}^j) = \circ\mathcal{V}^j$ . Consequently,  $q$  restricted to  $\circ\mathbf{B} = \circ\mathcal{U}^0 \cap \circ\mathbf{B}$  and  $\circ\mathbf{B}' = \circ\mathcal{U}^1 \cap \circ\mathbf{B}$  is a homeomorphism onto  $\circ\mathcal{B}^0$  and  $\circ\mathcal{B}^1$ , respectively. Define  $\circ\mathbf{B}^{\text{out}} = q^{-1}(\circ\mathcal{B}^{\text{out}}) \cap \circ\mathbf{B}$ .
- (3) For each  $y \in \circ\mathcal{U}$ , there exists a flow  $\psi_y$  such that
  - (a)  $\circ\mathbf{U}^j$  ( $j = 0, 1$ ) is an isolating neighborhood for the parametrized flow  $\{\psi_y\}_{y \in \circ\mathcal{U}^j}$  with  $\text{Inv}_{\psi_{\circ\mathcal{U}^j}}(\circ\mathbf{U}^j) = \circ\mathcal{U}^j$ . Let  $\circ\mathbf{U}_y^j$  denote  $q^{-1}(y)$  for  $y \in \circ\mathcal{U}^j \setminus \circ\mathcal{B}$ , and  $\circ\mathbf{U}_y^{j,-}$  the corresponding exit set. Similarly, let  $\circ\mathbf{B}_y$  denote  $q^{-1}(y)$  for  $y \in \circ\mathcal{B}$ . Let  $\circ\mathbf{U}^{j,-} = \cup_{y \in \circ\mathcal{U}^j} \circ\mathbf{U}_y^{j,-}$  for  $j = 0, 1$ .

- (b) For each  $y \in \mathcal{U}^0$ ,  ${}^\circ\mathbf{U}_y^0$  is homeomorphic to  $[-r, r]^k$  and  ${}^\circ\mathbf{U}_y^{0,-}$  is homeomorphic to  $[-r, r]^s \times \partial[-r, r]^{k-s}$  for some  $r > 0$ . Also  ${}^\circ\mathcal{U}_y^0 = q^{-1}(y) \cap {}^\circ\mathcal{U}^0$  has a  $(k-s)$ -dimensional unstable manifold.
- (c)  ${}^\circ\mathbf{B}_y$  is an isolating neighborhood of the parametrized flow  $\{\psi_y\}_{y \in {}^\circ\mathcal{B}}$  whose exit set is denoted by  ${}^\circ\mathbf{B}_y^-$ . Let  ${}^\circ\mathbf{B}^- = \cup_{y \in {}^\circ\mathcal{B}} {}^\circ\mathbf{B}_y^-$ .  ${}^\circ\mathbf{B}_y$  admits an attractor-repeller decomposition  $\{M_y(2), M_y(1)\}$ , where  $M_y(2) = {}^\circ\mathcal{U}_y^0$  and  $M_y(1) = {}^\circ\mathcal{U}_y^1$ . Moreover, there is no connecting orbits for any  $y \in {}^\circ\mathcal{B}^{\text{in}} \cup {}^\circ\mathcal{B}^{\text{out}}$ .

- (4) The set  ${}^\circ\mathbf{L}$  is the union of  ${}^\circ\mathbf{V}^j$  ( $j = 0, 1$ ) and  ${}^\circ\mathbf{P}$ , where

$${}^\circ\mathbf{V}^j = q^{-1}({}^\circ\mathcal{V}^j) \quad (j = 0, 1)$$

and

$$\begin{aligned} {}^\circ\mathbf{P} = & \left( \bigcup_{j=0,1} \bigcup_{y \in \mathcal{U}^j \setminus {}^\circ\mathcal{B}} {}^\circ\mathbf{U}_y^{j,-} \right) \cup {}^\circ\mathbf{B}^- \cup W_{\circ\mathbf{B}}^u({}^\circ\mathcal{B}^{\text{out}}) \cup \\ & \rho(\text{cl}({}^\circ\mathbf{U}^{0,-} \setminus {}^\circ\mathbf{B}), {}^\circ\mathbf{B}, \psi) \cup \rho(\text{cl}({}^\circ\mathbf{U}^{1,-} \setminus {}^\circ\mathbf{B}), {}^\circ\mathbf{B}, \psi). \end{aligned}$$

Note that, in general, for given an invariant set  $Y \subset N$  of a parametrized flow  $\varphi$ , the set  $\rho(Y, N, \varphi)$  denotes the push forward set of  $Y$  in  $N$  under  $\varphi$ . See Appendix A for the precise definition.

**Definition 2.3** Let  $\text{LM}_i = ({}^\circ\mathcal{U}_i^0, {}^\circ\mathcal{U}_i^1, {}^\circ\mathcal{V}_i^0, {}^\circ\mathcal{V}_i^1, {}^\circ\mathbf{U}_i^0, {}^\circ\mathbf{U}_i^1, {}^\circ\mathbf{B}_i, {}^\circ\mathbf{L}_i, q_i)$ ,  $i = 1, \dots, I$  be a collection of local models associated with the corresponding slow local models  $({}^\circ\mathcal{U}_i^0, {}^\circ\mathcal{U}_i^1, {}^\circ\mathcal{V}_i^0, {}^\circ\mathcal{V}_i^1, \mathcal{P}_i, h_i)$  together with the associated fibrations  $p_i : {}^\circ\mathcal{U}_i \rightarrow K_i = [\alpha_i, \alpha'_i]$ . Let  ${}^\circ\mathbf{U}_i(\alpha'_i) := q_i^{-1}(p_i^{-1}(\alpha'_i))$  and  ${}^\circ\mathbf{V}_i(\alpha'_i) := {}^\circ\mathbf{V}_i^1 \cap {}^\circ\mathbf{U}_i(\alpha'_i)$ . We say the collection of local models is *compatible*, if, for any  $i = 2, \dots, I$ , each  $\text{LM}_i$  is compatible with  $\text{LM}_{i-1}$  in the sense that there is an identification homeomorphism

$$\xi_i : {}^\circ\mathbf{U}_i(\alpha'_i) \rightarrow {}^\circ\mathbf{U}_{i-1}(\alpha_{i-1})$$

that maps  ${}^\circ\mathbf{V}_i(\alpha'_i)$  to  ${}^\circ\mathbf{V}_{i-1}(\alpha_{i-1})$ , homeomorphically, and that induces a homeomorphism  $\tilde{\xi}_i : {}^\circ\mathcal{U}_i(\alpha'_i) \rightarrow {}^\circ\mathcal{U}_{i-1}(\alpha_{i-1})$ .

Note that this identification homeomorphism may very well be the identity map. However, in practice, we want to connect the local models by these identification maps and make an isolating neighborhood, in which case, simply taking the union of these local models may cause a problem, because part of a local model might intersect with some other local model. Therefore it is theoretically better to abstractly connect the local models by identifying their ends with the adjacent ones. This is simply the purpose of introducing the identification homeomorphism  $\xi_i$ .



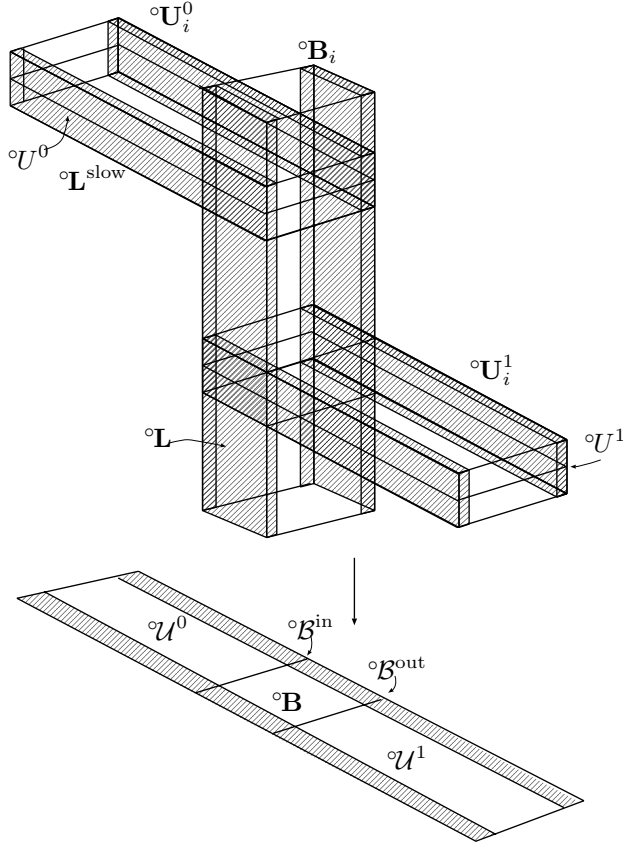

Figure 5: Local model.

If a collection of compatible local models  $\{\mathbf{LM}_i\}_{i=1,\dots,I}$  is such that  $\mathbf{LM}_I$  is also compatible with  $\mathbf{LM}_1$ , then we say that the collection is of *periodic* type. Otherwise it is said to be of *heteroclinic* type. For periodic case, it will be convenient to define  $\mathbf{LM}_0 = \mathbf{LM}_I$  and consider compatible local models  $\{\mathbf{LM}_i\}_{i=0,\dots,I}$ .

Given a compatible collection of local models

$$\mathbf{LM}_i = (\circ U_i^0, \circ U_i^1, \circ V_i^0, \circ V_i^1, \circ \mathbf{U}_i^0, \circ \mathbf{U}_i^1, \circ \mathbf{B}_i, \circ \mathbf{L}_i, q_i) \quad i = 1, \dots, I,$$

be it periodic or heteroclinic, define

$$\begin{aligned} \circ \mathbf{N}_i &= \circ \mathbf{U}_i^0 \cup \circ \mathbf{B}_i \cup \circ \mathbf{U}_i^1, \\ \circ \mathbf{N} &= \left( \bigsqcup_{i=1}^I \circ \mathbf{N}_i \right) / \sim_\xi, & \circ \mathbf{L} &= \left( \bigsqcup_{i=1}^I \circ \mathbf{L}_i \right) / \sim_\xi, \end{aligned}$$

where  $\sim_\xi$  stands for the identification by the homeomorphisms  $\{\xi_i\}_{i=1,\dots,I}$ . We also define the auxiliary sets as follows:

$$\begin{aligned}\mathcal{U} &= \left( \bigsqcup_{i=1}^I \mathcal{U}_i \right) / \sim_\xi, & \mathcal{V} &= \bigsqcup_{i=1}^I \mathcal{V}_i / \sim_\xi, \\ \circ\mathbf{L}^{\text{slow}} &= \left( \bigsqcup_{i=1}^I (\circ\mathbf{V}_i^0 \cup \circ\mathbf{V}_i^1) \right) / \sim_\xi, \\ \circ\mathbf{L}^{\text{fast}} &= \bigsqcup_{i=1}^I \circ\mathbf{P}_i / \sim_\xi.\end{aligned}$$

Here the identification  $\sim_\xi$  for  $\mathcal{U}$  and  $\mathcal{V}$  must be understood as identification by the corresponding maps  $\{\tilde{\xi}_i\}_{i=1,\dots,I}$ .

Our goal is to show that the pair  $(\circ\mathbf{N}, \circ\mathbf{L})$  is a singular index pair for a periodic or heteroclinic orbit of the fast-slow system, and that the existence of such an orbit can be detected by the information of the associated index. The former will be done in Section 5. In order to obtain the index information, in Section 3, we introduce the notion of an *index bundle*, which is a language that relates index information of the slow dynamics and fast dynamics. We show, step by step, that the pairs  $(\mathcal{U}, \mathcal{V})$ ,  $(\circ\mathbf{N}, \circ\mathbf{L}^{\text{slow}})$ ,  $(\circ\mathbf{N}, \circ\mathbf{L}^{\text{fast}})$ , and then  $(\circ\mathbf{N}, \circ\mathbf{L})$  are index bundles, under an appropriate condition.

Once the collection of compatible local models  $\text{LM}_i$  is pasted together, the result of index computation strongly depends on how the exit set of one local model be related to the next. This kind of information can be built in as the sequence of transition matrices associated with each box. More precisely, for every  $i$ , choose  $y_i \in \circ\mathcal{B}_i^{\text{in}} \setminus \mathcal{V}$  and  $y'_i \in \circ\mathcal{B}'_i{}^{\text{out}} \setminus \mathcal{V}$ . From the assumption on the absence of connecting orbit at  $y_i$  and  $y'_i$ , the transition matrix  $T_i^*$  between  $y_i$  and  $y'_i$  is well-defined. We can define a map  $\Theta$  for a global model by

$$\Theta(j, m) := T_m^*(2, 1) \circ T_{m-1}^*(2, 1) \circ \dots \circ T_{j+1}^*(2, 1) \circ T_j^*(2, 1), \quad (2.1)$$

and

$$\Theta := \Theta(1, I),$$

where

$$T_i^*(2, 1) : CH^*(M_{z_i}(1, \circ\mathbf{B}_i)) \rightarrow CH^*(M_{y_i}(2, \circ\mathbf{B}_i))$$

denotes the corresponding off-diagonal entry (or more generally the submatrix) in  $T_i^*$ .

Clearly, if all  $T_j^*(2, 1)$ ,  $j = 1, \dots, I$  are isomorphisms, then  $\Theta$  is an isomorphism, and if all  $T_j^*(2, 1) \neq 0$ ,  $j = 1, \dots, I$ , then  $\Theta \neq 0$ .

### 3 Index bundles for compatible local models

In this section, given compatible local models  $\{\text{LM}_i\}_{i=1,\dots,I}$ , we show that the pair  $(\circ\mathbf{N}, \circ\mathbf{L})$  decomposes into fast and slow pairs and that the slow pair forms

an index bundle. The fast pair forms an index bundle as well, provided the map  $\Theta$  is an isomorphism. This information is then summarized in a commutative diagram in Theorem 3.17.

Recall that we have already introduced the notion of index bundle in Introduction. If  $(X, Y)$  is an index bundle over a base space  $A$  which is path-connected, then  $H^*(X(a), Y(a))$  and  $H^*(X(a'), Y(a'))$  are isomorphic for any  $a, a' \in A$ . From now on, the base space of an index bundle is assumed to be path-connected.

**Definition 3.1** A pair  $(F, F')$  is a *fiber* of an index bundle  $(X, Y)$  over  $A$ , if

$$H^*(F, F') \cong H^*(X(a), Y(a))$$

for all  $a \in A$ .

**Definition 3.2** A *cohomological extension* of an index bundle  $(X, Y)$  over  $A$  is a homomorphism

$$e : H^*(F, F') \rightarrow H^*(X, Y)$$

such that for each  $a \in A$

$$H^*(F, F') \xrightarrow{e} H^*(X, Y) \rightarrow H^*(X(a), Y(a))$$

is an isomorphism.

### 3.1 Slow index bundle

#### 3.1.1 Local slow index bundle

Let  $(\mathcal{U}_i^0, \mathcal{U}_i^1, \mathcal{V}_i^0, \mathcal{V}_i^1, \mathcal{B}_i, h_i, p_i)$  be a slow local model. In Section 2, we have defined a fibration  $\bar{p}_i : \mathcal{U}_i \rightarrow J_i$  from the fibration  $p_i : \mathcal{U}_i \rightarrow K_i$ .

**Lemma 3.3** *Each pair  $(\mathcal{U}_i, \mathcal{V}_i)$  is an index bundle over base  $K_i$  with the projection  $p_i$ , and an index bundle over base  $J_i$  with the projection  $\bar{p}_i$ .*

*Proof.* This immediately follows from the condition (2) of Definition 2.1, and the definition of  $\bar{p}_i$ .  $\square$

#### 3.1.2 Slow index bundle

Given a collection of slow local models  $(\mathcal{U}_i^0, \mathcal{U}_i^1, \mathcal{V}_i^0, \mathcal{V}_i^1, \mathcal{B}_i, h_i, p_i)$ ,  $i = 1, \dots, I$ , recall

$$\mathcal{U} = \bigsqcup_{i=1}^I \mathcal{U}_i / \sim_\xi, \quad \mathcal{V} = \bigsqcup_{i=1}^I \mathcal{V}_i / \sim_\xi,$$

where  $\sim_\xi$  is the identification by  $\{\tilde{\xi}_i\}_{i=1, \dots, I}$ , see Definition 2.3. Let  $K$  and  $J$  be similarly defined by concatenating the intervals  $K_i$  and  $J_i$  respectively. Note that, if the collection of compatible local models is of heteroclinic type,  $K$  and

$J$  are both homeomorphic to an interval. If however it is of periodic type, then they are homeomorphic to a circle. Define a projection  $p : \mathcal{U} \rightarrow K$  by

$$p(x) = p_i(x) \quad \text{for } x \in \mathcal{U}_i$$

and, similarly, define  $\bar{p} : \mathcal{U} \rightarrow J$  by

$$\bar{p}(x) = \bar{p}_i(x) \quad \text{for } x \in \mathcal{U}_i.$$

**Lemma 3.4** *The pair  $(\mathcal{U}, \mathcal{V})$  is an index bundle over  $K$  with the projection  $p$  and an index bundle over  $J$  with the projection  $\bar{p}$ .*

*Proof.* In view of Lemma 3.3, we need to show that there is a homotopy equivalence between the pairs  $(\mathcal{U}(\lambda), \mathcal{V}(\lambda))$  and  $(\mathcal{U}(W), \mathcal{V}(W))$  for each  $\lambda \in W$ , where  $W$  is an open subset of  $K$  such that  $W$  intersects both  $K_{i-1}$  and  $K_i$  for some  $i$ . Assume without loss of generality that  $\lambda \in K_i$ . By Definition 2.1,  $(\mathcal{U}(W) \cap \mathcal{U}_i, \mathcal{V}(W) \cap \mathcal{U}_i)$  is homotopically equivalent to the fiber  $(\mathcal{U}_i(\alpha'_i), \mathcal{V}_i(\alpha'_i))$ , which by Definition 2.3 is homeomorphic to the pair  $(\mathcal{U}_{i-1}(\alpha_{i-1}), \mathcal{V}_{i-1}(\alpha_{i-1}))$ . By Lemma 3.3, this is equivalent to  $(\mathcal{U}(W) \cap \mathcal{U}_{i-1}, \mathcal{V}(W) \cap \mathcal{U}_{i-1})$  and, therefore, to  $(\mathcal{U}(\lambda), \mathcal{V}(\lambda))$  for any  $\lambda \in K_{i-1}$ . The result for base  $J$  follows immediately.  $\square$

### 3.1.3 Extension of the slow index bundle

We want to extend the bundle structure of  $\mathcal{U}$  with projection  $p : \mathcal{U} \rightarrow J$  to a bundle structure of the set  ${}^\circ\mathbf{N}$ . Let

$$\bar{q}_i = \bar{p}_i \circ q_i : {}^\circ\mathbf{N}_i \rightarrow J_i$$

be a projection map, and

$$\bar{q} : {}^\circ\mathbf{N} \rightarrow J \tag{3.1}$$

be a projection map defined by

$$\bar{q}(z) = \bar{q}_i(z) \quad \text{if } z \in {}^\circ\mathbf{N}_i.$$

**Theorem 3.5** *The pair  $({}^\circ\mathbf{N}, {}^\circ\mathbf{L}^{\text{slow}})$  is an index bundle over  $J$  with the projection  $\bar{q}$ .*

*Proof.* From Lemma 3.3,  $(\mathcal{U}_i, \mathcal{V}_i)$  with projection  $\bar{p}_i : \mathcal{U}_i \rightarrow J_i$  is an index bundle. Since  $\bar{q}_i = \bar{p}_i \circ q_i$ , it is enough to show that for each fiber  $\Upsilon(\lambda)$  ( $\lambda \in J_i$ ), there is an isomorphism

$$H^*({}^\circ\mathbf{N} \cap \Upsilon(\lambda), {}^\circ\mathbf{L}^{\text{slow}} \cap \Upsilon(\lambda)) \cong H^*(\mathcal{U}_i(\lambda), \mathcal{V}_i(\lambda)). \tag{3.2}$$

By definition of the set  ${}^\circ\mathbf{L}_i^{\text{slow}}$ , we have  $q_i({}^\circ\mathbf{L}_i^{\text{slow}}) = \mathcal{V}_i$  and by definition of  ${}^\circ\mathbf{N}_i$ , we have  $q_i({}^\circ\mathbf{N}_i) = \mathcal{U}_i$ . Now we construct a homotopy inverse to the map  $q_i$ . First recall that, for each  $y \in \mathcal{U}_i$ , we denote by  ${}^\circ\mathbf{N}_y$  the set  ${}^\circ\mathbf{N} \cap (\mathbb{R}^k \times \{y\})$ . We

can view  ${}^\circ\mathbf{N}_i$  as a bundle with projection  $q_i$  and fibers  ${}^\circ\mathbf{N}_y$ . Let  $s_i : \mathcal{U}_i \rightarrow {}^\circ\mathbf{N}_i$  be a continuous section of this bundle. Then  $q_i \circ s_i : \mathcal{U}_i \rightarrow \mathcal{U}_i$  is the identity and  $s_i \circ q_i : {}^\circ\mathbf{N}_i \rightarrow {}^\circ\mathbf{N}_i$  is homotopic to the identity, since every fiber is a  $k$ -disc. This last fact follows directly from the construction for  $y \in \mathcal{U}_i \setminus \mathcal{B}_i$  and by assumption (1) of Definition 2.2 for  $y \in \mathcal{B}_i$ . Therefore the map  $s_i$  is a homotopy inverse to  $q_i$  on  ${}^\circ\mathbf{N}_i$ . Since  ${}^\circ\mathbf{L}_i^{\text{slow}}$  consists of entire fibers over  $\mathcal{V}_i$ , we see that in fact  $q_i$  maps the pair  $({}^\circ\mathbf{N}_i, {}^\circ\mathbf{L}_i^{\text{slow}})$  to the pair  $(\mathcal{U}_i, \mathcal{V}_i)$  and  $s_i$  maps  $(\mathcal{U}_i, \mathcal{V}_i)$  to  $({}^\circ\mathbf{N}_i, {}^\circ\mathbf{L}_i^{\text{slow}})$ . This shows that each pair  $({}^\circ\mathbf{N}_i(\lambda), {}^\circ\mathbf{L}_i^{\text{slow}}(\lambda))$  has the same cohomology as the corresponding pair  $(\mathcal{U}_i(\lambda), \mathcal{V}_i(\lambda))$ . Since  $({}^\circ\mathbf{N}, {}^\circ\mathbf{L}^{\text{slow}})$  and  $(\mathcal{U}, \mathcal{V})$  are the unions of  $({}^\circ\mathbf{N}_i, {}^\circ\mathbf{L}_i^{\text{slow}})$  and  $(\mathcal{U}_i, \mathcal{V}_i)$  respectively, the result follows for the total pair  $({}^\circ\mathbf{N}, {}^\circ\mathbf{L}^{\text{slow}})$ .  $\square$

**Theorem 3.6** *The index bundle  $({}^\circ\mathbf{N}, {}^\circ\mathbf{L}^{\text{slow}})$  admits a cohomological extension  $e_s$ .*

*Proof.* We first define a cohomological extension of the index bundle  $(\mathcal{U}, \mathcal{V})$ . By Definition 2.1, for each  $i$ , there are homotopy equivalences

$$e_i(\alpha_i) : (\mathcal{U}_i(\alpha_i), \mathcal{V}_i(\alpha_i)) \rightarrow (\mathcal{U}_i, \mathcal{V}_i)$$

and

$$e'_i(\alpha'_i) : (\mathcal{U}_i, \mathcal{V}_i) \rightarrow (\mathcal{U}_i(\alpha'_i), \mathcal{V}_i(\alpha'_i)).$$

We denote the homeomorphism given in Definition 2.3 by

$$h_i : (\mathcal{U}_i(\alpha'_i), \mathcal{V}_i(\alpha'_i)) \rightarrow (\mathcal{U}_{i-1}(\alpha_{i-1}), \mathcal{V}_{i-1}(\alpha_{i-1})).$$

Then, for each  $j$ , the map

$$e_j = e'_1(\alpha'_1) \circ e_1(\alpha_1) \circ h_2 \circ e'_2(\alpha'_2) \circ \dots \circ e'_{j-1}(\alpha'_{j-1}) \circ e_{j-1}(\alpha_{j-1}) \circ h_j \circ e'_j(\alpha'_j) \\ : (\mathcal{U}_j, \mathcal{V}_j) \rightarrow (\mathcal{U}_1(\alpha'_1), \mathcal{V}_1(\alpha'_1))$$

is a homotopy equivalence. Let  $e : (\mathcal{U}, \mathcal{V}) \rightarrow (\mathcal{U}_1(\alpha'_1), \mathcal{V}_1(\alpha'_1))$  be defined by  $e = e_j$  on  $\mathcal{U}_j$ , then it is a homotopy equivalence as well.

We designate  $(\mathcal{U}_1(\alpha'_1), \mathcal{V}_1(\alpha'_1))$  to be a fiber of the index bundle  $(\mathcal{U}, \mathcal{V})$ . By construction above the induced map

$$e^* : H^*(\mathcal{U}_1(\alpha'_1), \mathcal{V}_1(\alpha'_1)) \rightarrow H^*(\mathcal{U}, \mathcal{V})$$

is a cohomological extension of the index bundle  $(\mathcal{U}, \mathcal{V})$ .

Now, corresponding to the fiber  $(\mathcal{U}_1(\alpha'_1), \mathcal{V}_1(\alpha'_1))$  of the bundle  $(\mathcal{U}, \mathcal{V})$ , let

$$({}^\circ\mathbf{N}^{\text{fib}}, {}^\circ\mathbf{L}^{\text{fib,slow}}) := ({}^\circ\mathbf{N}_1(\alpha'_1), {}^\circ\mathbf{L}_1^{\text{slow}}(\alpha'_1)) = \bar{q}^{-1}(\mathcal{U}_1(\alpha'_1), \mathcal{V}_1(\alpha'_1))$$

be the fiber of the bundle  $({}^\circ\mathbf{N}, {}^\circ\mathbf{L}^{\text{slow}})$ . By (3.2), for any  $\lambda \in J$ , we have that the cohomology of the fiber of the bundle  $(\mathcal{U}, \mathcal{V})$  over  $\lambda \in J$  is the same as the

cohomology of the fiber of the bundle  $(\circ\mathbf{N}, \circ\mathbf{L}^{\text{slow}})$  over  $\lambda$ . Therefore  $e^*$  induces a cohomological extension of the index bundle  $(\circ\mathbf{N}, \circ\mathbf{L}^{\text{slow}})$

$$e_s : H^*(\circ\mathbf{N}^{\text{fib}}, \circ\mathbf{L}^{\text{fib,slow}}) \rightarrow H^*(\circ\mathbf{N}, \circ\mathbf{L}^{\text{slow}}).$$

□

## 3.2 Fast index bundle

### 3.2.1 Local fast index bundle

Let  $\gamma$  be a section of the bundle  $p : \mathcal{U} \rightarrow K$ , and let  $\gamma_i$  be a restriction of this section to the bundle  $p_i : \mathcal{U}_i \rightarrow K_i$ . We select the section  $\gamma$  in such a way that  $\gamma_i(K_i) \subset \mathcal{U}_i \setminus \mathcal{V}_i$ . Recall that, by Definition 2.3, there is an identification between the pairs  $(\mathcal{U}_i(\alpha'_i), \mathcal{V}_i(\alpha'_i))$  and  $(\mathcal{U}_{i-1}(\alpha_{i-1}), \mathcal{V}_{i-1}(\alpha_{i-1}))$ . We assume, without loss of generality, that the section  $\gamma$  is selected in such a way that  $\gamma_i(K_i) \cap \mathcal{U}_i(\alpha'_i)$  maps by this identification to  $\gamma_{i-1}(K_{i-1}) \cap \mathcal{U}_{i-1}(\alpha_{i-1})$ .

Let

$$\circ\mathbf{N}_{i,\gamma} := q_i^{-1}(\gamma_i(K_i)) \cap \circ\mathbf{N}_i,$$

and let  $\bar{q}_{i,\gamma} : \circ\mathbf{N}_{i,\gamma} \rightarrow J_i$  be the restriction of the projection  $\bar{q}_i$  to  $\circ\mathbf{N}_{i,\gamma}$ , namely,  $\bar{q}_{i,\gamma} := \bar{p}_i \circ (q_i|_{\circ\mathbf{N}_{i,\gamma}})$ .

The part of the box  $\circ\mathbf{B}_i$  over the segment  $\gamma_i \cap \circ\mathcal{B}_i$ , namely  $\circ\mathbf{B}_{i,\gamma} := \circ\mathbf{B}_i \cap \circ\mathbf{N}_{i,\gamma}$ , is a single fiber of the bundle over  $J_i$ . Let  $[\beta_i]$  be the point in  $J_i$  corresponding to the fiber. We denote by  $\circ\mathbf{U}_{i,\gamma}$  the collection of fibers

$$\circ\mathbf{U}_{i,\gamma}^j := \circ\mathbf{U}_i^j \cap \circ\mathbf{N}_{i,\gamma} \quad (j = 0, 1).$$

Let

$$\begin{aligned} \circ\mathbf{L}_{i,\gamma} &:= \circ\mathbf{L}_i \cap \circ\mathbf{N}_{i,\gamma} = \circ\mathbf{L}_i^{\text{fast}} \cap \circ\mathbf{N}_{i,\gamma} \\ \circ\mathbf{L}_{\circ\mathbf{U}_{i,\gamma}^j} &:= \circ\mathbf{U}_{i,\gamma}^j \cap \circ\mathbf{L}_i = \circ\mathbf{U}_{i,\gamma}^j \cap \circ\mathbf{U}_i^{j,-} \quad (j = 0, 1) \\ \circ\mathbf{L}_{\circ\mathbf{B}_{i,\gamma}} &:= \circ\mathbf{B}_{i,\gamma} \cap \circ\mathbf{L}_i = \circ\mathbf{B}_{i,\gamma} \cap \circ\mathbf{L}_i^{\text{fast}}, \end{aligned} \quad (3.3)$$

where the second equality in each line comes from the fact that  $\gamma_i \subset \mathcal{U}_i \setminus \mathcal{V}_i$  and the definition of  $\circ\mathbf{L}_i^{\text{slow}}$  and  $\circ\mathbf{L}_i^{\text{fast}}$ .

Recall (2.1) that  $\Theta$  is defined as a composition of transition matrices  $T_i^*(2, 1)$  with domain being the sum of the indices at  $y \in \circ\mathcal{B}_i^{\text{in}} \setminus \circ\mathcal{V}$  and range the sum of indices at  $y' \in \circ\mathcal{B}_i^{\text{out}} \setminus \circ\mathcal{V}$ . We can identify  $y$  with the point  $y_i := \gamma_i \cap (\circ\mathcal{B}_i^{\text{in}} \setminus \circ\mathcal{V})$ , and  $y'$  with the point  $y'_i := \gamma_i \cap (\circ\mathcal{B}_i^{\text{out}} \setminus \circ\mathcal{V})$ . Therefore the map  $T_i^*(2, 1)$  can be identified with the map  $\bar{T}_i^*(2, 1)$  within  $(\circ\mathbf{N}_{i,\gamma}, \circ\mathbf{L}_{i,\gamma})$ . Let  $\bar{\Theta}_i = \bar{T}_i^*(2, 1)$  be a map defined in (2.1) for a single box  $\circ\mathbf{B}_{i,\gamma}$ .

**Lemma 3.7** *If  $\bar{\Theta}_i$  is an isomorphism, then the pair  $(\circ\mathbf{N}_{i,\gamma}, \circ\mathbf{L}_{i,\gamma})$  is an index bundle over  $J_i$  with the projection  $\bar{q}_{i,\gamma}$ .*

*Proof.* The goal of the construction of  $(\circ\mathbf{N}_{i,\gamma}, \circ\mathbf{L}_{i,\gamma})$  lies in realization that the computation of the index for parameterized flow  $\psi_{i,\gamma}$  on  $(\circ\mathbf{N}_{i,\gamma}, \circ\mathbf{L}_{i,\gamma})$  is identical to computation carried out in [9]. Indeed,  $(\circ\mathbf{U}_{i,\gamma}, \circ\mathbf{L}_{\circ\mathbf{U}_{i,\gamma}})$  is a *tube* and  $(\circ\mathbf{B}_{i,\gamma}, \circ\mathbf{L}_{\circ\mathbf{B}_{i,\gamma}})$  is the  $i$ -th box of the tube and box collection (see [9] for terminology).

We want to show that  $(\circ\mathbf{N}_{i,\gamma}, \circ\mathbf{L}_{i,\gamma})$  is a bundle over  $J_i$ . By construction,  $H^*(\circ\mathbf{B}_{i,\gamma}, \circ\mathbf{L}_{\circ\mathbf{B}_{i,\gamma}})$  is a single fiber of this bundle. We first take an open set  $W \subset J_i$  which does not contain  $b_i \in J_i$ ; for such an open set, the “natural tube continuation” (see Remark 2.11 in [9]) proves the required property (1.8). For an open set  $W \subset J_i$  which does contain  $b_i$ , we need the result of Proposition 4.6 of [9], which, in the present notation, shows that

$$H^*(\circ\mathbf{B}_{i,\gamma}, \circ\mathbf{L}_{\circ\mathbf{B}_{i,\gamma}}) \cong H^*(\circ\mathbf{N}_{i,\gamma}(\alpha'_i), \circ\mathbf{L}_{i,\gamma}(\alpha'_i)) \cong CH^*(M(1, i)). \quad (3.4)$$

Here  $\circ\mathbf{N}_{i,\gamma}(\alpha'_i) = \circ\mathbf{N}_{i,\gamma} \cap q_i^{-1}(\circ\mathcal{U}_i(\alpha'_i))$  and  $\circ\mathbf{L}_{i,\gamma}(\alpha'_i) = \circ\mathbf{N}_{i,\gamma}(\alpha'_i) \cap \circ\mathbf{L}_i$ . By assumption,  $\Theta_i : CH^*(M(1, i)) \rightarrow CH^*(M(2, i))$  is an isomorphism and therefore

$$CH^*(M(1, i)) \cong CH^*(M(2, i)) \cong H^*(\circ\mathbf{N}_{i,\gamma}(\beta'), \circ\mathbf{L}_{i,\gamma}(\beta')).$$

Finally, by the tube continuation

$$H^*(\circ\mathbf{N}_{i,\gamma}(\beta'), \circ\mathbf{L}_{i,\gamma}(\beta')) \cong H^*(\circ\mathbf{N}_{i,\gamma}(\lambda), \circ\mathbf{L}_{i,\gamma}(\lambda))$$

for any  $\lambda \in W$ . □

### 3.2.2 Fast index bundle

We want to join the local index bundles  $(\circ\mathbf{N}_{i,\gamma}, \circ\mathbf{L}_{i,\gamma})$  to a global index bundle  $(\circ\mathbf{N}_\gamma, \circ\mathbf{L}_\gamma)$  over the parameter spaces  $K$  or  $J$ . The above identification between the pairs  $(\circ\mathcal{U}_i(\alpha'_i), \circ\mathcal{V}_i(\alpha'_i))$  and  $(\circ\mathcal{U}_{i-1}(\alpha_{i-1}), \circ\mathcal{V}_{i-1}(\alpha_{i-1}))$  identifies the endpoint  $\gamma_i(K_i) \cap \circ\mathcal{U}_i(\alpha'_i)$  with the endpoint  $\gamma_{i-1}(K_{i-1}) \cap \circ\mathcal{U}_{i-1}(\alpha_{i-1})$ . Since the pair  $(\circ\mathbf{N}_{i,\gamma}(\alpha'_i), \circ\mathbf{L}_{i,\gamma}(\alpha'_i))$  is the intersection of  $(\circ\mathbf{N}_i(\alpha'_i), \circ\mathbf{L}_i(\alpha'_i))$  with the set  $\circ\mathbf{N}_{i,\gamma}$  and  $(\circ\mathbf{N}_{i-1,\gamma}(\alpha_{i-1}), \circ\mathbf{L}_{i-1,\gamma}(\alpha_{i-1}))$  is the intersection of  $(\circ\mathbf{N}_{i-1}(\alpha_{i-1}), \circ\mathbf{L}_{i-1}(\alpha_{i-1}))$  with  $\circ\mathbf{N}_{i-1,\gamma}$ , there is a natural identification

$$(\circ\mathbf{N}_{i-1,\gamma}(\alpha_{i-1}), \circ\mathbf{L}_{i-1,\gamma}(\alpha_{i-1})) \rightarrow (\circ\mathbf{N}_{i,\gamma}(\alpha'_i), \circ\mathbf{L}_{i,\gamma}(\alpha'_i)).$$

Observe that this construction is independent of the map  $\Theta_i$ . Let

$$\circ\mathbf{N}_\gamma := \bigcup_{i=1}^I \circ\mathbf{N}_{i,\gamma}, \quad \circ\mathbf{L}_\gamma := \bigcup_{i=1}^I \circ\mathbf{L}_{i,\gamma}.$$

We note that, as with the global slow index bundle,  $\circ\mathbf{N}_\gamma$  is a bundle over  $J$  which is an interval for the case of heteroclinic corridor and a circle  $S^1$  for the case of periodic corridor.

Let  $\bar{q}_\gamma : \circ\mathbf{N}_\gamma \rightarrow J$  be a projection defined by  $\bar{q}_\gamma(x) = \bar{q}_{i,\gamma}(x)$  for  $x \in \circ\mathbf{N}_{i,\gamma}$ .

**Lemma 3.8** *If  $\bar{\Theta}_i$  is an isomorphism for all  $i = 1, \dots, I$ , then  $({}^\circ\mathbf{N}_\gamma, {}^\circ\mathbf{L}_\gamma)$  is an index bundle over  $J$  with projection  $\bar{q}_\gamma$ .*

*Proof.* Similarly as in Theorem 3.5 for the slow index bundle, we need to connect the local index bundles  $({}^\circ\mathbf{N}_{i,\gamma}, {}^\circ\mathbf{L}_{i,\gamma})$  to make a global index bundle  $({}^\circ\mathbf{N}_\gamma, {}^\circ\mathbf{L}_\gamma)$ . To do this, we only need to show that there is an isomorphism

$$H^*({}^\circ\mathbf{N}_\gamma(W), {}^\circ\mathbf{L}_\gamma(W)) \cong H^*({}^\circ\mathbf{N}_\gamma(\lambda), {}^\circ\mathbf{L}_\gamma(\lambda))$$

for any  $\lambda \in W$ , where  $W$  is an open set in  $J$  which intersects  $J_i$  and  $J_{i-1}$  for some  $i$ . Assume without loss of generality again that  $\lambda \in J_{i-1}$ . By (3.4),

$$\begin{aligned} H^*({}^\circ\mathbf{N}_{i,\gamma}(W \cap J_i), {}^\circ\mathbf{L}_{i,\gamma}(W \cap J_i)) &\cong H^*({}^\circ\mathbf{N}_{i,\gamma}(\alpha'_i), {}^\circ\mathbf{L}_{i,\gamma}(\alpha'_i)) \\ &\cong CH^*(M(1, i-1)) \\ &\cong H^*({}^\circ\mathbf{N}_{i-1,\gamma}(\alpha_{i-1}), {}^\circ\mathbf{L}_{i-1,\gamma}(\alpha_{i-1})), \end{aligned}$$

where by Definition 2.2(2), the last group is isomorphic, via the continuation isomorphism, to  $H^*({}^\circ\mathbf{N}_{i-1,\gamma}(\lambda), {}^\circ\mathbf{L}_{i-1,\gamma}(\lambda))$  for any  $\lambda \in J_{i-1}$ .  $\square$

**Lemma 3.9** *There is a map*

$$e_f : ({}^\circ\mathbf{N}_{1,\gamma}(\alpha'_1), {}^\circ\mathbf{L}_{1,\gamma}(\alpha'_1)) \rightarrow ({}^\circ\mathbf{N}_\gamma, {}^\circ\mathbf{L}_\gamma)$$

*which is a cohomological extension, provided  $\bar{\Theta} := \bar{\Theta}_I \circ \dots \circ \bar{\Theta}_1$  is an isomorphism.*

*Proof.* From Proposition 4.6 in [9], there is an isomorphism

$$\Psi := \Psi(I) : H^*({}^\circ\mathbf{N}_\gamma, {}^\circ\mathbf{L}_\gamma) \rightarrow H^*({}^\circ\mathbf{N}_{1,\gamma}(\alpha'_1), {}^\circ\mathbf{L}_{1,\gamma}(\alpha'_1)).$$

We designate  $({}^\circ\mathbf{N}_{1,\gamma}(\alpha'_1), {}^\circ\mathbf{L}_{1,\gamma}(\alpha'_1))$  as a fiber of the index bundle  $({}^\circ\mathbf{N}_\gamma, {}^\circ\mathbf{L}_\gamma)$ . Define

$$e_f := \Psi^{-1} : H^*({}^\circ\mathbf{N}_{1,\gamma}(\alpha'_1), {}^\circ\mathbf{L}_{1,\gamma}(\alpha'_1)) \rightarrow H^*({}^\circ\mathbf{N}_\gamma, {}^\circ\mathbf{L}_\gamma).$$

Let  $j_\gamma(\lambda)$  be the inclusion map  $j_\gamma(\lambda) : ({}^\circ\mathbf{N}_\gamma(\lambda), {}^\circ\mathbf{L}_\gamma(\lambda)) \rightarrow ({}^\circ\mathbf{N}_\gamma, {}^\circ\mathbf{L}_\gamma)$  for some  $\lambda \in J \setminus \cup_{i=1}^I \{[\beta_i]\}$ . Using natural tube identification, it has been shown in [9] that all maps  $j_\gamma(\lambda)$  for  $\lambda \in J_k$  are homotopic and thus can be identified as a single map  $j_{k,\gamma}$ .

By Proposition 4.8 in [9], we have that

$$j_{k,\gamma} := \bar{\Theta}(k) \circ \Psi.$$

Consequently the composition

$$H^*({}^\circ\mathbf{N}_{1,\gamma}(\alpha'_1), {}^\circ\mathbf{L}_{1,\gamma}(\alpha'_1)) \xrightarrow{\Psi^{-1}} H^*({}^\circ\mathbf{N}_\gamma, {}^\circ\mathbf{L}_\gamma) \xrightarrow{j_{k,\gamma}} H^*({}^\circ\mathbf{N}_\gamma(\lambda), {}^\circ\mathbf{L}_\gamma(\lambda))$$

is equal to

$$H^*({}^\circ\mathbf{N}_{1,\gamma}(\alpha'_1), {}^\circ\mathbf{L}_{1,\gamma}(\alpha'_1)) \xrightarrow{\bar{\Theta}(k)} H^*({}^\circ\mathbf{N}_\gamma(\lambda), {}^\circ\mathbf{L}_\gamma(\lambda)).$$

Since  $\bar{\Theta}(k)$  is an isomorphism for each  $k$ ,  $e_f$  is a cohomological extension.  $\square$



### 3.2.3 Extension of the fast bundle

As we have done with a pair  $(\circ\mathbf{N}, \circ\mathbf{L}^{\text{slow}})$ , we can view  $(\circ\mathbf{N}, \circ\mathbf{L}^{\text{fast}})$  as a bundle with projection  $\bar{q} : \circ\mathbf{N} \rightarrow J$ . Recall that this means that, for each  $\lambda \in J \setminus \bigcup_{i=1}^I \{[\beta_i]\}$ , where  $[\beta_i]$  is the point in  $J_i$  whose fiber is  $\circ\mathbf{B}_i$ , the fiber of the bundle is

$$(\circ\mathbf{N}(\lambda), \circ\mathbf{L}^{\text{fast}}(\lambda)) := (\circ\mathbf{N} \cap \Upsilon(\lambda), \circ\mathbf{L}^{\text{fast}} \cap \Upsilon(\lambda)),$$

and for  $\lambda = [\beta_i]$ , the fiber of this bundle is

$$(\circ\mathbf{B}_i, \circ\mathbf{L}^{\text{fast}} \cap \circ\mathbf{B}_i).$$

We want to relate the cohomology of a fiber of the bundle  $(\circ\mathbf{N}, \circ\mathbf{L}^{\text{fast}})$  to the cohomology of the corresponding fiber of the bundle  $(\circ\mathbf{N}_\gamma, \circ\mathbf{L}_\gamma)$ . To this end we define the projection  $\bar{q}_i^{\text{fast}} : \circ\mathbf{N}_i \rightarrow \circ\mathbf{N}_{i,\gamma}$  by the requirement that

$$\bar{q}_{i,\gamma} \circ \bar{q}_i^{\text{fast}} = \bar{q}_i.$$

Let  $\bar{q}^{\text{fast}} : \circ\mathbf{N} \rightarrow \circ\mathbf{N}_\gamma$  be defined by  $\bar{q}^{\text{fast}}(z) = \bar{q}_i^{\text{fast}}(z)$  if  $z \in \circ\mathbf{N}_i$ .

**Lemma 3.10**

$$H^*(\circ\mathbf{N}_\gamma(\lambda), \circ\mathbf{L}_\gamma(\lambda)) \cong H^*(\circ\mathbf{N}(\lambda), \circ\mathbf{L}^{\text{fast}}(\lambda)) \quad (3.5)$$

for all  $\lambda \in J$ .

*Proof.* We first take  $\lambda \neq [\beta_i]$  for any  $i$ . Then, by the construction of the fibration, we have  $q^{-1}(\lambda) \cap \circ\mathbf{B}_i = \emptyset$ . It follows that

$$(\circ\mathbf{N}(\lambda), \circ\mathbf{L}^{\text{fast}}(\lambda)) = (\circ\mathbf{U}_i^j \cap q^{-1}(\lambda), \circ\mathbf{U}_i^{j,-} \cap q^{-1}(\lambda)),$$

where  $j = 0$  if  $\lambda \in [\alpha_i, \beta_i]$ , and  $j = 1$  if  $\lambda \in [\beta'_i, \alpha'_i]$ . Take  $y \in \gamma \cap q^{-1}(\lambda)$ . By the construction of  $\circ\mathbf{U}_i^j$  and  $\circ\mathbf{U}_i^{j,-}$  we get

$$\bar{q}^{\text{fast}}(\circ\mathbf{U}_i^j) = \circ\mathbf{U}_y^j \quad \text{and} \quad \bar{q}^{\text{fast}}(\circ\mathbf{U}_i^{j,-}) = \circ\mathbf{U}_y^{j,-}.$$

Finally we have

$$\circ\mathbf{U}_y^j = \circ\mathbf{N}_\gamma(\lambda), \quad \text{and} \quad \circ\mathbf{U}_y^{j,-} = \circ\mathbf{N}_\gamma^-(\lambda),$$

which proves (3.5).

Now we consider  $\lambda = [\beta_i]$ , in which case  $(\circ\mathbf{N}([\beta_i]), \circ\mathbf{L}^{\text{fast}}([\beta_i])) = (\circ\mathbf{B}_i, \circ\mathbf{L}^{\text{fast}} \cap \circ\mathbf{B}_i)$ . We first prove some preliminary results.

**Claim 3.11**

$$\circ\mathbf{B}_i \cong \mathcal{U}_i(\alpha'_i) \times \circ\mathbf{B}_{i,\gamma}.$$

*Proof.* Since the projection  $\circ\mathcal{B}_i$  of the box  $\circ\mathbf{B}_i$  is the set of the form  $\circ\mathcal{B}_i = \bigcup_{\lambda \in [\beta_i, \beta'_i]} \mathcal{U}_i(\lambda)$  and  $\gamma_i$ , as a section of the bundle with fibers  $\mathcal{U}_i(\lambda)$ , intersects each fiber exactly once, the result follows.  $\square$

**Claim 3.12**

$${}^{\circ}\mathbf{L}^{\text{fast}} \cap {}^{\circ}\mathbf{B}_i \cong \mathcal{U}_i(\beta'_i) \times {}^{\circ}\mathbf{L}_{\circ\mathbf{B}_i, \gamma}.$$

*Proof.* We describe the pair

$$(\bar{q}^{\text{fast}}({}^{\circ}\mathbf{B}_i), \bar{q}^{\text{fast}}({}^{\circ}\mathbf{L}^{\text{fast}} \cap {}^{\circ}\mathbf{B}_i)).$$

Obviously,  $\bar{q}^{\text{fast}}({}^{\circ}\mathbf{B}_i) = {}^{\circ}\mathbf{B}_{i, \gamma}$  by construction of  $\bar{q}^{\text{fast}}$ . The set  ${}^{\circ}\mathbf{L}^{\text{fast}} \cap {}^{\circ}\mathbf{B}_i$  consists of three sets

$$\begin{aligned} {}^{\circ}\mathbf{L}^{\text{fast}} \cap {}^{\circ}\mathbf{B}_i &= \rho({}^{\circ}\mathbf{U}_i^{0, -} \setminus \mathring{\mathbf{B}}_i, \mathring{\mathbf{B}}_i, \psi^{\beta_i}) \cup \rho({}^{\circ}\mathbf{U}_i^{1, -} \setminus \mathring{\mathbf{B}}_i, \mathring{\mathbf{B}}_i, \psi^{\beta'_i}) \\ &\cup W_{\circ\mathbf{B}_i}^u({}^{\circ}\mathcal{U}_i(\beta'_i)) \cup \mathring{\mathbf{B}}_i^-. \end{aligned}$$

It is easy to see that, by definition of the fast exit set  $\mathring{\mathbf{B}}_i^-$ , we get  $\bar{q}^{\text{fast}}(\mathring{\mathbf{B}}_i^-) = \mathring{\mathbf{B}}_{i, \gamma}^-$ .

By assumption  $q_i({}^{\circ}\mathcal{U}_i(\beta'_i)) = \mathcal{U}_i(\beta'_i)$ . Recall that  $\mathcal{U}_i(\beta'_i) \subset \mathring{\mathcal{B}}_i^{\text{in}} \cup \mathring{\mathcal{B}}_i^{\text{out}}$ . Since  $\mathring{\mathcal{B}}_i^{\text{in}} \cap \mathring{\mathcal{B}}_i^{\text{out}} = \emptyset$ ,  $\mathring{\mathcal{B}}_i^{\text{in}}, \mathring{\mathcal{B}}_i^{\text{out}}$  are both open and  $\mathcal{U}_i(\beta'_i)$  is connected, we have  $\mathcal{U}_i(\beta'_i) \subset \mathring{\mathcal{B}}_i^{\text{in}}$  or  $\mathcal{U}_i(\beta'_i) \subset \mathring{\mathcal{B}}_i^{\text{out}}$ . Therefore it takes a finite time for a point  $z \in W_{\circ\mathbf{B}_i}^u({}^{\circ}\mathcal{U}_i(\beta'_i))$  to leave  $\mathring{\mathbf{B}}_i$ . It follows that  $W_{\circ\mathbf{B}_i}^u({}^{\circ}\mathcal{U}_i(\beta'_i))$  is homotopic to  ${}^{\circ}\mathcal{U}_i(\beta'_i)$ . The image of the set  ${}^{\circ}\mathcal{U}_i(\beta'_i)$  under the projection  $\bar{q}^{\text{fast}}$  is the point  $y'_i$ . Thus  $\bar{q}^{\text{fast}}(W_{\circ\mathbf{B}_i}^u({}^{\circ}\mathcal{U}_i(\beta'_i)))$  is homotopic to  $W_{\circ\mathbf{B}_i}^u(y'_i)$ .

A similar argument can be applied to the set  $\rho({}^{\circ}\mathbf{U}_i^{0, -} \setminus \mathring{\mathbf{B}}_i, \mathring{\mathbf{B}}_i, \psi^{\beta_i})$ . Since  $\Pi(\rho({}^{\circ}\mathbf{U}_i^{0, -} \setminus \mathring{\mathbf{B}}_i, \mathring{\mathbf{B}}_i, \psi^{\beta_i})) \subset \mathcal{U}_i(\beta_i)$ , we can get by a similar argument as above that  $\mathcal{U}_i(\beta_i) \subset \mathring{\mathcal{B}}_i^{\text{in}}$  or  $\mathcal{U}_i(\beta_i) \subset \mathring{\mathcal{B}}_i^{\text{out}}$ . It follows that it takes a finite time for a point  $z \in {}^{\circ}\mathbf{U}_i^{0, -}$  to leave  $\mathring{\mathbf{B}}_i$  and therefore  $\rho({}^{\circ}\mathbf{U}_i^{0, -} \setminus \mathring{\mathbf{B}}_i, \mathring{\mathbf{B}}_i, \psi^{\beta_i})$  is homotopically equivalent to  $\rho({}^{\circ}\mathbf{U}_{i, y}^{0, -} \setminus \mathring{\mathbf{B}}_{i, y}, \mathring{\mathbf{B}}_{i, y}, \psi_y^{\beta_i})$  where  $y := y_i$ . An analogous argument works for  $\rho({}^{\circ}\mathbf{U}_i^{1, -} \setminus \mathring{\mathbf{B}}_i, \mathring{\mathbf{B}}_i, \psi^{\beta'_i})$ .

Thus taken together

$$\begin{aligned} \bar{q}^{\text{fast}}({}^{\circ}\mathbf{L}^{\text{fast}} \cap {}^{\circ}\mathbf{B}_i) &\cong \mathring{\mathbf{B}}_{i, \gamma}^- \cup \rho({}^{\circ}\mathbf{U}_{i, y}^{0, -} \setminus \mathring{\mathbf{B}}_{i, y}, \mathring{\mathbf{B}}_{i, y}, \psi_y^{\beta_i}) \\ &\cup \rho({}^{\circ}\mathbf{U}_{i, y}^{1, -} \setminus \mathring{\mathbf{B}}_{i, y}, \mathring{\mathbf{B}}_{i, y}, \psi_y^{\beta'_i}) \cup W_{\circ\mathbf{B}_i}^u(y'_i) \\ &\cong {}^{\circ}\mathbf{L}_{\circ\mathbf{B}_i, \gamma}. \end{aligned}$$

This, together with the definition of  $\bar{q}^{\text{fast}}$  and the foliation  $\{\Upsilon(\lambda)\}$ , implies that

$${}^{\circ}\mathbf{L}^{\text{fast}} \cap {}^{\circ}\mathbf{B}_i \cong {}^{\circ}\mathbf{L}_{\circ\mathbf{B}_i, \gamma} \times \mathcal{U}_i(\beta'_i).$$

This finishes the proof of the Claim.  $\square$

It follows from Claim 3.11 and 3.12 that

$$({}^{\circ}\mathbf{B}, {}^{\circ}\mathbf{L}^{\text{fast}} \cap {}^{\circ}\mathbf{B}_i) \cong ({}^{\circ}\mathbf{B}_{i, \gamma} \times \mathcal{U}_i(\beta'_i), {}^{\circ}\mathbf{L}_{i, \gamma} \times \mathcal{U}_i(\beta'_i)).$$

Since  $\mathcal{U}_i(\beta'_i)$  is homeomorphic to a disc  $D^{l-1}$ , (3.5) follows for  $\lambda = [\beta_i]$ .  $\square$

**Theorem 3.13** *If  $\Theta$  is an isomorphism then the pair  $(\circ\mathbf{N}, \circ\mathbf{L}^{\text{fast}})$  is an index bundle over  $J$  with projection  $\bar{q}$  and admits a cohomological extension  $e_f$ .*

*Proof.* Since by (3.5) the cohomology of fibers of  $(\circ\mathbf{N}, \circ\mathbf{L}^{\text{fast}})$  is the same as cohomology of corresponding fibers of  $(\circ\mathbf{N}_\gamma, \circ\mathbf{L}_\gamma)$ , cohomological extension  $e_f$  on the bundle  $(\circ\mathbf{N}_\gamma, \circ\mathbf{L}_\gamma)$  can be viewed as cohomological extension on the bundle  $(\circ\mathbf{N}, \circ\mathbf{L}^{\text{fast}})$ , with the fiber

$$(\circ\mathbf{N}^{\text{fib}}, \circ\mathbf{L}^{\text{fib,fast}}) := (\bar{q}^{\text{fast}})^{-1}(\circ\mathbf{N}_{1,\gamma}(\beta'_1), \circ\mathbf{L}_{1,\gamma}(\beta'_1)). \quad (3.6)$$

□

### 3.3 Total index bundle

The goal of this subsection is to show that  $(\circ\mathbf{N}, \circ\mathbf{L})$  is an index bundle over  $J$ .

**Theorem 3.14** *For each  $\lambda \in J_i$ , there is an isomorphism*

$$D^*(\lambda) : H^*(\circ\mathcal{U}_i(\lambda), \circ\mathcal{V}_i(\lambda)) \otimes H^*(\circ\mathbf{N}_{i,\gamma}(\lambda), \circ\mathbf{L}_{i,\gamma}(\lambda)) \rightarrow H^*(\circ\mathbf{N}_i(\lambda), \circ\mathbf{L}_i(\lambda)).$$

*For the fiber  $\lambda = [\beta_i]$ , this takes the form*

$$H^*(\circ\mathbf{B}_i, \circ\mathbf{L}_i \cap \circ\mathbf{B}_i) \cong H^*(\circ\mathcal{U}_i(\beta'_i), \circ\mathcal{V}_i(\beta'_i)) \otimes H^*(\circ\mathbf{B}_{i,\gamma}, \circ\mathbf{L}_{\circ\mathbf{B}_{i,\gamma}}).$$

*Proof.* We start with  $\lambda \in J_i, \lambda \neq [\beta_i]$ . In the following computation, we use the definition of  $\circ\mathbf{U}, \circ\mathbf{U}^-$  and  $\circ\mathbf{L}$ .

$$\begin{aligned} & H^*(\circ\mathbf{U}_i^j(\lambda), \circ\mathbf{U}_i^j(\lambda) \cap \circ\mathbf{L}_i) \\ & \cong H^*([-r, r]^k \times \circ\mathcal{U}_i^j(\lambda), \circ\mathbf{U}_i^{j,-}(\lambda) \cup \bigcup_{y \in \circ\mathcal{V}_i^j(\lambda)} \circ\mathbf{N}_y) \\ & \cong H^*([-r, r]^k \times \circ\mathcal{U}_i^j(\lambda), [-r, r]^s \times \partial[-r, r]^{k-s} \times \circ\mathcal{U}_i^j(\lambda) \\ & \quad \cup \bigcup_{y \in \circ\mathcal{V}_i^j(\lambda)} \circ\mathbf{U}_y^j) \\ & \cong H^*(\circ\mathbf{U}_y^j \times \circ\mathcal{U}_i^j(\lambda), \circ\mathbf{U}_{i,y}^{j,-} \times \circ\mathcal{U}_i^j(\lambda) \cup \circ\mathbf{U}_{i,y}^j \times \circ\mathcal{V}_i^j(\lambda)) \\ & \cong H^*(\circ\mathcal{U}_i^j(\lambda), \circ\mathcal{V}_i^j(\lambda)) \otimes H^*(\circ\mathbf{U}_{i,y}^j, \circ\mathbf{U}_{i,y}^{j,-}) \end{aligned} \quad (3.7)$$

where  $y$  is any point in  $\circ\mathcal{U}_i^j(\lambda)$ .

Now we take  $\lambda = [\beta_i]$ . In the first line of the following computation we use Claim 3.11 and Claim 3.12.

$$\begin{aligned}
H^*(\circ\mathbf{B}_i, \circ\mathbf{L}_i \cap \circ\mathbf{B}_i) & \\
&\cong H^*(\circ\mathcal{U}_i(\beta'_i) \times \circ\mathbf{B}_{i,\gamma}, \circ\mathbf{L}_{\circ\mathbf{B}_i,\gamma} \times \circ\mathcal{U}_i(\beta'_i) \cup (\circ\mathbf{L}_i^{\text{slow}} \cap \circ\mathbf{B}_i)) \\
&\cong H^*(\circ\mathcal{U}_i(\beta'_i) \times \circ\mathbf{B}_{i,\gamma}, \\
&\quad \circ\mathbf{L}_{\circ\mathbf{B}_i,\gamma} \times \circ\mathcal{U}_i(\beta'_i) \cup \bigcup_{y \in \circ\mathcal{V}_i \cap \circ\mathcal{B}_i} \circ\mathbf{N}_y) \\
&\cong H^*(\circ\mathcal{U}_i(\beta'_i) \times \circ\mathbf{B}_{i,\gamma}, \circ\mathbf{L}_{\circ\mathbf{B}_i,\gamma} \times \circ\mathcal{U}_i(\beta'_i) \cup \circ\mathcal{V}_i(\beta'_i) \times \circ\mathbf{B}_{i,\gamma}) \\
&\cong H^*(\circ\mathcal{U}_i(\beta'_i), \circ\mathcal{V}_i(\beta'_i)) \otimes H^*(\circ\mathbf{B}_{i,\gamma}, \circ\mathbf{L}_{\circ\mathbf{B}_i,\gamma})
\end{aligned}$$

Here the third equality follows from

$$\begin{aligned}
\bigcup_{y \in \circ\mathcal{V}_i \cap \circ\mathcal{B}_i} \circ\mathbf{N}_y &\simeq (\circ\mathcal{V}_i \cap \circ\mathcal{B}_i) \times \circ\mathbf{N}_y \\
&\simeq (\circ\mathcal{V}_i \cap \circ\mathcal{U}_i(\beta'_i)) \times (\gamma_i \cap \circ\mathcal{B}_i) \times \circ\mathbf{N}_y \\
&\simeq \circ\mathcal{V}_i(\beta'_i) \times \circ\mathbf{B}_{i,\gamma}.
\end{aligned}$$

□

**Theorem 3.15** *If  $\Theta$  is an isomorphism,  $(\circ\mathbf{N}, \circ\mathbf{L}^{\text{slow}} \cup \circ\mathbf{L}^{\text{fast}})$  is an index bundle over  $J$ .*

*Proof.* By Theorem 3.14, each fiber of  $(\circ\mathbf{N}, \circ\mathbf{L}^{\text{slow}} \cup \circ\mathbf{L}^{\text{fast}})$  over the base  $J$  is a product of a fiber of the index bundle  $(\circ\mathbf{N}, \circ\mathbf{L}^{\text{slow}})$  and a fiber of  $(\circ\mathbf{N}, \circ\mathbf{L}^{\text{fast}})$ . Since  $(\circ\mathbf{N}, \circ\mathbf{L}^{\text{slow}})$  is an index bundle, all fibers  $(\circ\mathbf{N}(\lambda), \circ\mathbf{L}^{\text{slow}}(\lambda))$  have the same cohomology.

If  $\Theta$  is an isomorphism, by Theorem 3.13,  $(\circ\mathbf{N}, \circ\mathbf{L}^{\text{fast}})$  is also an index bundle and all the fibers of  $(\circ\mathbf{N}, \circ\mathbf{L}^{\text{fast}})$  have the same cohomology. It follows then that all fibers of  $(\circ\mathbf{N}, \circ\mathbf{L}^{\text{fast}} \cup \circ\mathbf{L}^{\text{slow}})$  have the same cohomology. □

### 3.4 Key diagram

**Lemma 3.16 ([20] 5.6.8)** *Let  $f : X \rightarrow Y$  map  $A_1$  into  $B_1$  and  $A_2$  into  $B_2$  and let  $u \in H^p(Y, B_1)$  and  $v \in H^q(Y, B_2)$ . Let  $f_1 : (X, A_1) \rightarrow (Y, B_1)$ ,  $f_2 : (X, A_2) \rightarrow (Y, B_2)$  and  $\bar{q} : (X, A_1 \cup A_2) \rightarrow (Y, B_1 \cup B_2)$  be maps defined by  $f$ . In  $H^{p+q}(X, A_1 \cup A_2)$ , we have*

$$\bar{q}^*(u \smile v) = f_1^*u \smile f_2^*v.$$

**Theorem 3.17** *The following diagram commutes for all  $\lambda$ :*

$$\begin{array}{ccc}
H^*(\circ\mathbf{N}^{\text{fib}}, \circ\mathbf{L}^{\text{fib,fast}}) \otimes H^*(\circ\mathbf{N}^{\text{fib}}, \circ\mathbf{L}^{\text{fib,slow}}) & \xrightarrow{D^{*\text{fib}}} & H^*(\circ\mathbf{N}^{\text{fib}}, \circ\mathbf{L}^{\text{fib,fast}} \cup \circ\mathbf{L}^{\text{fib,slow}}) \\
\downarrow e_f \otimes e_s & & \downarrow \overline{e_f \otimes e_s} \\
H^*(\circ\mathbf{N}, \circ\mathbf{L}^{\text{fast}}) \otimes H^*(\circ\mathbf{N}, \circ\mathbf{L}^{\text{slow}}) & \xrightarrow{D^*} & H^*(\circ\mathbf{N}, \circ\mathbf{L}^{\text{fast}} \cup \circ\mathbf{L}^{\text{slow}}) \\
\downarrow i^* & & \downarrow i^* \\
H^*(\circ\mathbf{N}(\lambda), \circ\mathbf{L}^{\text{fast}}(\lambda)) \otimes H^*(\circ\mathbf{N}(\lambda), \circ\mathbf{L}^{\text{slow}}(\lambda)) & \xrightarrow{D^*(\lambda)} & H^*(\circ\mathbf{N}(\lambda), \circ\mathbf{L}^{\text{fast}}(\lambda) \cup \circ\mathbf{L}^{\text{slow}}(\lambda))
\end{array}$$

where the map  $\overline{e_f \otimes e_s}$  is given by  $D^* \circ (e_f \otimes e_s) \circ (D^{*\text{fib}})^{-1}$  and  $D^*$ ,  $D^{*\text{fib}}$ ,  $D^*(\lambda)$  are given by the cup product. Notice that from Theorem 3.14, the horizontal maps  $D^*(\lambda)$  and  $D^{*\text{fib}}$  in the diagram are isomorphisms.

*Proof.* We observe that  $(\circ\mathbf{L}^{\text{fast}}, \circ\mathbf{L}^{\text{slow}})$  is an excisive pair in  $\circ\mathbf{N}$  and thus the cup product map

$$D^* : H^*(\circ\mathbf{N}, \circ\mathbf{L}^{\text{fast}}) \otimes H^*(\circ\mathbf{N}, \circ\mathbf{L}^{\text{slow}}) \xrightarrow{\sim} H^*(\circ\mathbf{N}, \circ\mathbf{L}^{\text{fast}} \cup \circ\mathbf{L}^{\text{slow}})$$

is well-defined. The same result holds for the fast part of the left vertical line in the diagram, since it is formed by restriction of the above sets to the section  $q_1^{-1}(\mathcal{U}_1(\beta'_1))$  of the set  $\circ\mathbf{N}$ , and the right vertical line by the similar argument, see Theorem 3.14.

The lower square of diagram commutes by Lemma 3.16 applied to the inclusion  $i$ . The upper square of the diagram commutes by definition.  $\square$

**Corollary 3.18** *If  $\Theta$  is an isomorphism,  $(\circ\mathbf{N}, \circ\mathbf{L}^{\text{slow}} \cup \circ\mathbf{L}^{\text{fast}})$  admits a cohomological extension  $\overline{e_f \otimes e_s}$ .*

*Proof.* By Theorem 3.13, if  $\Theta$  is an isomorphism,  $(\circ\mathbf{N}, \circ\mathbf{L}^{\text{fast}})$  admits a cohomological extension  $e_f$ . By Theorem 3.6,  $(\circ\mathbf{N}, \circ\mathbf{L}^{\text{slow}})$  admits a cohomological extension  $e_s$ . By Theorem 3.15,  $(\circ\mathbf{N}, \circ\mathbf{L}^{\text{slow}} \cup \circ\mathbf{L}^{\text{fast}})$  is an index bundle. The result now follows from the Key diagram in the above Theorem 3.17.  $\square$

## 4 Homology computation of an index bundle

In this section, we carry out the index computation.

## 4.1 Leray-Hirsch Theorem for index bundles

For related argument for fiber bundles see [20]. Let  $(F, F')$  be a pair such that  $H_*(F, F'; \mathfrak{K})$  is free and finitely generated over  $\mathfrak{K}$ . All results in this section are valid for  $\mathfrak{K}$  being a principal ideal domain, but since such generality is not needed, we will assume that  $\mathfrak{K}$  is a field.

**Theorem 4.1** *Let  $(X, Y)$  be an index bundle with a compact base space  $A$  and let  $(F, F')$  be its fiber. Assume that  $H^*(F, F')$  is finitely generated over a field  $\mathfrak{K}$ . Assume also that, for any sufficiently small open set  $W \subset A$ , we have*

$$H^*(X(W), Y(W)) \cong H^*(W) \otimes H^*(F, F').$$

Then

$$H^*(X, Y) \cong H^*(A) \otimes H^*(F, F').$$

*Proof.* By assumption, for all sufficiently small open neighborhoods  $W \subset A$ , there is an isomorphism

$$i_W^* : H^*(W) \otimes H^*(F, F') \rightarrow H^*(X(W), Y(W)).$$

If  $W$  and  $W'$  are two such open neighborhoods, then by Theorem 4.6.3 in [20], it is easy to see that  $\{(X(W), Y(W)), (X(W'), Y(W'))\}$  is an excisive couple. It follows, from the property 5.6.20 in [20], that the maps  $i_W, i_{W'}, i_{W \cup W'}, i_{W \cap W'}$  send the exact Mayer-Vietoris sequence of  $(X(W), Y(W))$  and  $(X(W'), Y(W'))$  to the tensor product of the exact Mayer-Vietoris sequence of  $W$  and  $W'$  with  $H^*(F, F')$ . Since  $H^*(F, F')$  is free over  $\mathfrak{K}$ , its tensor product with any exact sequence is exact. Therefore, if  $i_W, i_{W'}$  and  $i_{W \cap W'}$  are isomorphisms, it follows from the five lemma that  $i_{W \cup W'}$  is an isomorphism. By induction,  $i_W$  is an isomorphism for any set  $W$  which is a finite union of sufficiently small open sets. Since  $A$  is compact,  $A$  is such a set.  $\square$

**Lemma 4.2** *Let  $(X, Y)$  be an index bundle with a compact base space  $A$  and let  $(F, F')$  be its fiber. Assume that there is a cohomological extension of the fiber. If  $W$  is a simply connected subset of  $A$ , then*

$$H^*(X(W), Y(W)) \cong H^*(W) \otimes H^*(F, F').$$

*Proof.* Since  $W$  is simply connected, the reduced cohomology  $\tilde{H}_*(W)$  vanishes. By definition of the cohomological extension, denoted by  $e$ ,

$$H^*(F, F') \xrightarrow{e} H^*(X(W), Y(W)) \xrightarrow{i^*} H^*(X(a), Y(a))$$

is an isomorphism. Since  $(X, Y)$  and therefore also  $(X(W), Y(W))$  is an index bundle, the map  $i^*$  is an isomorphism and hence so is  $e$ . Taking tensor product with  $H^*(W) = H^0(W)$  gives the desired result.  $\square$

**Corollary 4.3** *Let  $(X, Y)$  be an index bundle with a compact base space  $A$  and let  $(F, F')$  be its fiber. Assume that  $H^*(F, F')$  is finitely generated over a field  $\mathfrak{K}$  and that there is a cohomological extension of the fiber. Assume that  $A$  admits an open cover  $\{W_i\}$  such that each  $W_i$  is simply connected, and that if  $W_i \cap W_j \neq \emptyset$  then  $W_i \cap W_j = \bigcup_k O_k$ , where each  $O_k$  is simply connected. Then we have*

$$H^*(X, Y) \cong H^*(A) \otimes H^*(F, F').$$

*Proof.* By Lemma 4.2, for any two sets  $W_i, W_j$  from the open cover, we have

$$\begin{aligned} H^*(X(W_i), Y(W_i)) &\cong H^*(W_i) \otimes H^*(F, F'), \\ H^*(X(W_j), Y(W_j)) &\cong H^*(W_j) \otimes H^*(F, F'), \\ H^*(X(W_i \cap W_j), Y(W_i \cap W_j)) &\cong H^*(W_i \cap W_j) \otimes H^*(F, F'). \end{aligned}$$

The rest follows from Theorem 4.1.  $\square$

## 4.2 Cohomology of index bundles

**Theorem 4.4** *Let  $(\circ\mathbf{N}, \circ\mathbf{L})$  be the index bundle obtained from a collection of compatible local models  $\mathbf{LM}_i = (\circ\mathcal{U}_i^0, \circ\mathcal{U}_i^1, \circ\mathcal{V}_i^0, \circ\mathcal{V}_i^1, \circ\mathbf{U}_i^0, \circ\mathbf{U}_i^1, \circ\mathbf{B}_i, \circ\mathbf{L}_i, q_i)$ ,  $i = 1, \dots, I$ . Assume it is of periodic type so that the base space  $J$  of  $(\circ\mathbf{N}, \circ\mathbf{L})$  is a circle. Assume furthermore that for each  $i = 1, \dots, I$ ,*

$$CH^j(M(1, i); \mathbb{Z}_2) \cong \begin{cases} \mathbb{Z}_2 & \text{if } j = s; \\ 0 & \text{otherwise} \end{cases}$$

and

$$H^j(\circ\mathcal{U}, \circ\mathcal{V}; \mathbb{Z}_2) \cong \begin{cases} \mathbb{Z}_2 & \text{if } j = p, p + 1; \\ 0 & \text{otherwise.} \end{cases}$$

If  $\Theta$  is an isomorphism, then

$$H^j(\circ\mathbf{N}, \circ\mathbf{L}; \mathbb{Z}_2) \cong \begin{cases} \mathbb{Z}_2 & \text{if } j = s + p, s + p + 1; \\ 0 & \text{otherwise} \end{cases}.$$

*Proof.* Since the corridor is periodic, the base  $J$  for the index bundle will be a circle  $\mathbb{S}^1$ . Clearly,  $\mathbb{S}^1$  admits covering which satisfy assumptions of Corollary 4.3. Let  $\gamma : K \rightarrow \mathcal{U} \setminus \mathcal{V}$  be a section as a base for fast index bundle in the total index bundle  $(\circ\mathbf{N}, \circ\mathbf{L})$ . Since  $\Theta$  is an isomorphism, it follows from Theorem 3.13 that  $(\circ\mathbf{N}, \circ\mathbf{L}^{\text{fast}})$  is an index bundle. We then have that

$$\begin{aligned} CH^*(M(1, 1)) &\cong H^*(\circ\mathbf{N}_{1, \gamma}(\beta'_1), \circ\mathbf{L}_{1, \gamma}(\beta'_1)) && \text{(from (3.4))} \\ &\cong (\bar{q}^{\text{fast}})(H^*(\circ\mathbf{N}^{\text{fib}}, \circ\mathbf{L}^{\text{fib, fast}})) && \text{(from (3.6) and Theorem 3.13)} \\ &\cong H^*(\circ\mathbf{N}^{\text{fib}}, \circ\mathbf{L}^{\text{fib, fast}}) && \text{(from (3.5))} \end{aligned}$$

is the fiber of the fast bundle. Also

$$H^*(\mathcal{U}_1(\beta'_1), \mathcal{V}_1(\beta'_1)) \cong H^*(\mathbf{N}^{\text{fib}}, \mathbf{L}^{\text{fib,slow}})$$

is a cohomology of a fiber in a slow index bundle. From the Leray-Hirsch Theorem (Corollary 4.3), we have

$$H^*(\gamma) \otimes H^*(\mathcal{U}_1(\beta'_1), \mathcal{V}_1(\beta'_1)) \cong H^*(\mathcal{U}, \mathcal{V}).$$

Since  $\Theta$  is an isomorphism, by Corollary 3.18,  $(\mathbf{N}, \mathbf{L})$  admits a cohomological extension  $\overline{e_s \otimes e_f}$ . By Theorem 3.14, the cohomology  $H^*(\mathbf{N}^{\text{fib}}, \mathbf{L}^{\text{fib}})$  of a fiber of the index bundle  $(\mathbf{N}, \mathbf{L})$  is a product

$$\begin{aligned} H^*(\mathbf{N}^{\text{fib}}, \mathbf{L}^{\text{fib}}) &\cong H^*(\mathbf{N}^{\text{fib}}, \mathbf{L}^{\text{fib,slow}}) \otimes (\mathbf{N}^{\text{fib}}, \mathbf{L}^{\text{fib,fast}}) \\ &\cong H^*(\mathcal{U}_1(\beta'_1), \mathcal{V}_1(\beta'_1)) \otimes CH^*(M(1, 1)). \end{aligned}$$

By Corollary 4.3, the cohomology of the total bundle is a product of the cohomology of a fiber and the cohomology of  $\gamma$ . It follows that

$$\begin{aligned} H^*(\mathbf{N}, \mathbf{L}) &\cong H^*(\mathbf{N}^{\text{fib}}, \mathbf{L}^{\text{fib}}) \otimes H^*(\gamma) \\ &\cong H^*(\mathcal{U}, \mathcal{V}) \otimes CH^*(M(1, 1)) \\ &\cong H^*(\mathcal{U}_1(\beta'_1), \mathcal{V}_1(\beta'_1)) \otimes H^*(\gamma) \otimes CH^*(M(1, 1)) \\ &\cong \begin{cases} \mathbb{Z}_2 & \text{if } * = s + p, s + p + 1; \\ 0 & \text{otherwise.} \end{cases} \end{aligned}$$

□

**Lemma 4.5** *For all  $i = 1, \dots, I$  we have*

$$H^*(\mathbf{N}_i, \mathbf{L}_i) \cong H^*(\mathbf{N}_i(\beta'_i), \mathbf{L}_i(\beta'_i)).$$

*Proof.* Recall that  $\mathbf{N}_i = \mathbf{U}_i^0 \cup \mathbf{B}_i \cup \mathbf{U}_i^1$ . Consider a Mayer-Vietoris sequence

$$\begin{aligned} \dots &\rightarrow H^*(\mathbf{U}_i^0 \cup \mathbf{B}_i \cup \mathbf{U}_i^1, \mathbf{L} \cap (\mathbf{U}_i^0 \cup \mathbf{B}_i \cup \mathbf{U}_i^1)) \\ &\rightarrow H^*(\mathbf{U}_i^0 \cup \mathbf{B}_i, \mathbf{L} \cap (\mathbf{U}_i^0 \cup \mathbf{B}_i)) \oplus H^*(\mathbf{U}_i^1, \mathbf{L} \cap \mathbf{U}_i^1) \quad (4.1) \\ &\rightarrow H^*(\mathbf{N}_i(\beta'), \mathbf{L}_i(\beta')) \rightarrow \dots \end{aligned}$$

Observe that by Theorem 3.14, we have

$$H^*(\mathbf{N}_i(\beta'_i), \mathbf{L}_i(\beta'_i)) \cong H^*(\mathcal{U}_i(\beta'_i), \mathcal{V}_i(\beta'_i)) \otimes H^*(\mathbf{U}_{i,y}, \mathbf{U}_{i,y}^-)$$

for some  $y$ . Since  $(\mathcal{U}_i, \mathcal{V}_i)$  is an index bundle by Lemma 3.3,

$$H^*(\mathcal{U}_i^0, \mathcal{V}_i^0) \cong H^*(\mathcal{U}_i(\beta'_i), \mathcal{V}_i(\beta'_i)).$$



It follows that

$$\begin{aligned}
H^*(\circ\mathbf{U}_i^1, \circ\mathbf{L} \cap \circ\mathbf{U}_i^1) &\cong H^*(\circ\mathbf{U}_{i,y} \times \circ\mathcal{U}_i^1, \circ\mathbf{U}_{i,y} \times \circ\mathcal{V}_i^1 \cup \circ\mathbf{U}_{i,y}^- \times \circ\mathcal{U}_i^1) \\
&\cong H^*(\circ\mathcal{U}_i^1, \circ\mathcal{V}_i^1) \otimes H^*(\circ\mathbf{U}_{i,y}, \circ\mathbf{U}_{i,y}^-) \\
&\cong H^*(\circ\mathcal{U}_i(\beta'_i), \circ\mathcal{V}_i(\beta'_i)) \otimes H^*(\circ\mathbf{U}_{i,y}, \circ\mathbf{U}_{i,y}^-) \\
&\cong H^*(\circ\mathbf{N}_i(\beta'_i), \circ\mathbf{L}_i(\beta'_i)).
\end{aligned}$$

In view of (4.1), we have

$$H^*(\circ\mathbf{U}_i^0 \cup \circ\mathbf{B}_i \cup \circ\mathbf{U}_i^1, \circ\mathbf{L} \cap (\circ\mathbf{U}_i^0 \cup \circ\mathbf{B}_i \cup \circ\mathbf{U}_i^1)) \cong H^*(\circ\mathbf{U}_i^0 \cup \circ\mathbf{B}_i, \circ\mathbf{L} \cap (\circ\mathbf{U}_i^0 \cup \circ\mathbf{B}_i)).$$

Similar argument leads to

$$H^*(\circ\mathbf{U}_i^0, \circ\mathbf{L} \cap \circ\mathbf{U}_i^0) \cong H^*(\circ\mathbf{N}_i(\beta_i), \circ\mathbf{L}_i(\beta_i)),$$

and therefore, in view of another Mayer-Vietoris sequence

$$\begin{aligned}
\dots &\rightarrow H^*(\circ\mathbf{U}_i^0 \cup \circ\mathbf{B}_i, \circ\mathbf{L} \cap (\circ\mathbf{U}_i^0 \cup \circ\mathbf{B}_i)) \\
&\rightarrow H^*(\circ\mathbf{U}_i^0, \circ\mathbf{L} \cap \circ\mathbf{U}_i^0) \oplus H^*(\circ\mathbf{B}_i, \circ\mathbf{L} \cap \circ\mathbf{B}_i) \\
&\rightarrow H^*(\circ\mathbf{N}_i(\beta_i), \circ\mathbf{L}_i(\beta_i)) \quad \rightarrow \dots
\end{aligned}$$

it follows that

$$H^*(\circ\mathbf{U}_i^0 \cup \circ\mathbf{B}_i, \circ\mathbf{L} \cap (\circ\mathbf{U}_i^0 \cup \circ\mathbf{B}_i)) \cong H^*(\circ\mathbf{B}_i, \circ\mathbf{L} \cap \circ\mathbf{B}_i).$$

Now we compute  $H^*(\circ\mathbf{B}_i, \circ\mathbf{L} \cap \circ\mathbf{B}_i)$ .

$$\begin{aligned}
H^*(\circ\mathbf{B}_i, \circ\mathbf{L} \cap \circ\mathbf{B}_i) &\cong H^*(\circ\mathcal{U}_i(\beta'_i), \circ\mathcal{V}_i(\beta'_i)) \otimes H^*(\circ\mathbf{B}_{i,\gamma}, L \cap \circ\mathbf{B}_{i,\gamma}) \\
&\stackrel{\text{id} \otimes \Psi(i)}{\cong} H^*(\circ\mathcal{U}_i(\beta'_i), \circ\mathcal{V}_i(\beta'_i)) \otimes CH^*(M(1, i)) \\
&\cong H^*(\circ\mathcal{U}_i(\beta'_i), \circ\mathcal{V}_i(\beta'_i)) \otimes H^*(\circ\mathbf{U}_{i,y}, \circ\mathbf{U}_{i,y}^-) \\
&\cong H^*(\circ\mathbf{N}_i(\beta'_i), \circ\mathbf{L}_i(\beta'_i)),
\end{aligned}$$

where first and last isomorphism follows from Theorem 3.14, and  $\Psi(i)$  is the isomorphism from Proposition 4.6 [9].  $\square$

Let  $\circ\mathbf{N}\langle 1, j \rangle := \bigsqcup_{i=1}^j (\circ\mathbf{U}_i^0 \cup \circ\mathbf{B}_i \cup \circ\mathbf{U}_i^1) / \sim$  and  $\circ\mathbf{L}\langle 1, j \rangle := \bigsqcup_{i=1}^j \circ\mathbf{L}_i / \sim$ .

**Theorem 4.6** For all  $j = 1, \dots, I$  we have

$$H^*(\circ\mathbf{N}\langle 1, j \rangle, \circ\mathbf{L}\langle 1, j \rangle) \cong H^*(\circ\mathbf{N}_1(\beta'_1), \circ\mathbf{L}_1(\beta'_1)).$$

*Proof.* Consider Mayer-Vietoris sequence

$$\begin{aligned}
\dots &\rightarrow H^*(\circ\mathbf{N}\langle 1, j+1 \rangle, \circ\mathbf{L}\langle 1, j+1 \rangle) \\
&\rightarrow H^*(\circ\mathbf{N}\langle 1, j \rangle, \circ\mathbf{L}\langle 1, j \rangle) \oplus H^*(\circ\mathbf{N}_{j+1}, \circ\mathbf{L}_{j+1}) \quad (4.2) \\
&\rightarrow H^*(\circ\mathbf{N}_{j+1}(\beta'_1), \circ\mathbf{L}_{j+1}(\beta'_1)) \quad \rightarrow \dots
\end{aligned}$$

By Lemma 4.5

$$H^*(\circ\mathbf{N}_{j+1}, \circ\mathbf{L}_{j+1}) \cong H^*(\circ\mathbf{N}_{j+1}(\beta'_1), \circ\mathbf{L}_{j+1}(\beta'_1))$$

and so

$$H^*(\circ\mathbf{N}\langle 1, j+1 \rangle, \circ\mathbf{L}\langle 1, j+1 \rangle) \cong H^*(\circ\mathbf{N}\langle 1, j \rangle, \circ\mathbf{L}\langle 1, j \rangle)$$

for all  $j$ . In particular, for  $j = 0$  we get

$$H^*(\circ\mathbf{N}\langle 1, 2 \rangle, \circ\mathbf{L}\langle 1, 2 \rangle) \cong H^*(\circ\mathbf{N}\langle 1, 1 \rangle, \circ\mathbf{L}\langle 1, 1 \rangle) = H^*(\circ\mathbf{N}_1, \circ\mathbf{L}_1)$$

where for the last set we have from Lemma 4.5

$$H^*(\circ\mathbf{N}_1, \circ\mathbf{L}_1) \cong H^*(\circ\mathbf{N}_1(\beta'_1), \circ\mathbf{L}_1(\beta'_1)).$$

The rest now follows by induction.  $\square$

**Corollary 4.7** *There is an isomorphism*

$$H^*(\circ\mathbf{N}\langle 1, I \rangle, \circ\mathbf{L}\langle 1, I \rangle) \cong H^*(\circ\mathbf{N}_1(\beta'_1), \circ\mathbf{L}_1(\beta'_1))$$

## 5 Periodic and heteroclinic corridors

In this section we provide precise definitions of periodic and heteroclinic corridors, which were referred to in the introduction. From the corridors we define a neighborhood  $\dagger\mathbf{N}$  and associated exit set  $\dagger\mathbf{L}$ . We formulate Theorems which prove that  $\dagger\mathbf{N}$  is a singular isolating neighborhood. Further we show that  $(\dagger\mathbf{N}, \dagger\mathbf{L})$  can be cut into pieces and reassembled to form a compatible collection of local models that is defined in Section 2.

Recall, that we have defined slow sheets in Definition 1.4, which are basic building blocks of the isolating neighborhood on slow manifolds.

**Definition 5.1** Let  $\dagger\mathcal{R} := \mathbb{D}^{\ell-1} \times [a, b]$  be an  $\ell$ -dimensional disc in  $\mathbb{R}^\ell$  the space of slow variables. Let  $\dagger\mathcal{R}^a := \mathbb{D}^{\ell-1} \times \{a\}$  and  $\dagger\mathcal{R}^b := \mathbb{D}^{\ell-1} \times \{b\}$  be  $(\ell - 1)$ -dimensional discs in the boundary  $\partial\dagger\mathcal{R}$ . We assume that for  $y \in \dagger\mathcal{R}^a \cup \dagger\mathcal{R}^b$  there is no connecting orbits in the invariant set  $S_y$  under parameterized flow. We call such set  $\dagger\mathcal{R}$  a *shaft*.

Let us consider a collection of slow sheets  $\{E_i\}_{i=0}^I$  determined by local sections  $\Sigma_i$  of slow manifolds  $M_i$ , and a collection of shafts  $\{\dagger\mathcal{R}_i\}_{i=1}^I$  such that:

**(H1)** The set

$$\dagger\mathcal{B}_i := \Pi(E_i) \cap \dagger\mathcal{R}_i \cap \Pi(E_{i-1}) \neq \emptyset \quad (5.1)$$

for all  $i = 1, \dots, I$ .

**(H2)** Let  $\dagger\mathcal{B}_i^\sigma := \dagger\mathcal{R}_i^\sigma \cap \dagger\mathcal{B}_i$  for  $\sigma = a, b$ . Then  $\dagger\mathcal{B}_i \cong \mathbb{D}^{\ell-1} \times [0, 1]$ , where  $\dagger\mathcal{B}_i^a \cup \dagger\mathcal{B}_i^b = \mathbb{D}^{\ell-1} \times \{0, 1\}$ .

(H3) The flow  $\Pi \circ \varphi_i^{\text{slow}}$  is transverse to all fibers  $\dagger\mathcal{R}_i^t := \mathbb{D}^{\ell-1} \times \{t\}$ ,  $t \in [a, b]$  and also the flow  $\Pi \circ \varphi_{i-1}^{\text{slow}}$  is transverse to all fibers  $\dagger\mathcal{R}_i^t := \mathbb{D}^{\ell-1} \times \{t\}$ ,  $t \in [a, b]$ .

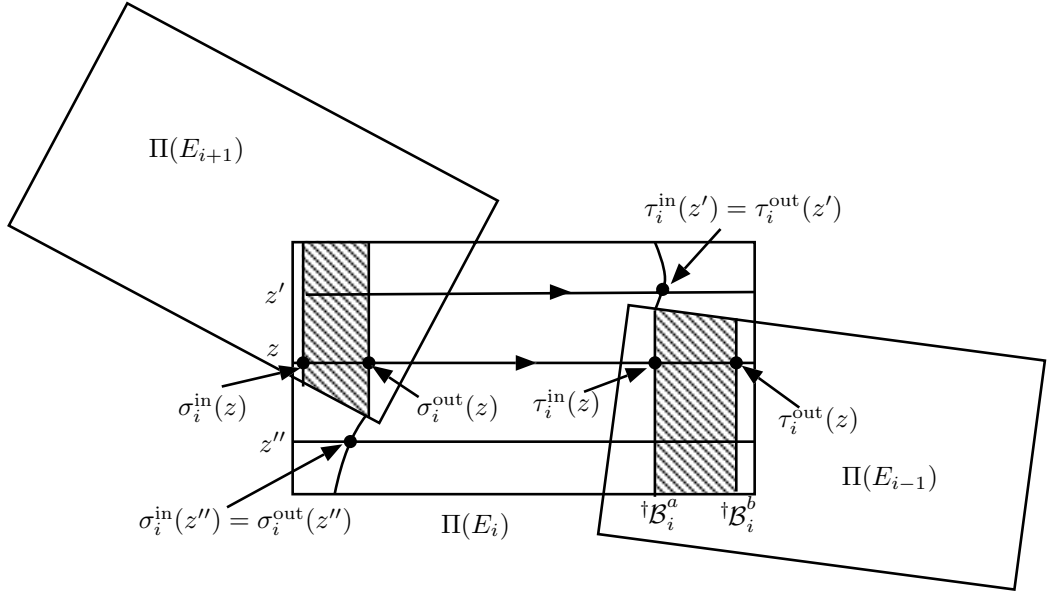

Figure 6: Time functions.

Given a collection  $\{\dagger\mathcal{B}_i\}_{i=1}^I$ , we let

$$\dagger B_i = \Pi^{-1}(\dagger\mathcal{B}_i) \cap E_i \text{ and } \dagger B'_i = \Pi^{-1}(\dagger\mathcal{B}_{i+1}) \cap E_i$$

be the corresponding sets on  $E_i$ . Let

$$\dagger\mathcal{B}_i^{\text{side}} := \text{cl}(\partial\dagger\mathcal{B}_i \setminus (\dagger\mathcal{B}_i^a \cup \dagger\mathcal{B}_i^b)),$$

$$\dagger B_i^\sigma := \Pi^{-1}(\dagger\mathcal{B}_i^\sigma) \cap \dagger B_i \text{ and } \dagger B'_i{}^\sigma := \Pi^{-1}(\dagger\mathcal{B}_{i+1}^\sigma) \cap \dagger B'_i \text{ for } \sigma = a, b;$$

$$\dagger B_i^{\text{side}} := \Pi^{-1}(\dagger\mathcal{B}_i^{\text{side}}) \cap E_i \text{ and } \dagger B'_i{}^{\text{side}} = \Pi^{-1}(\dagger\mathcal{B}_{i+1}^{\text{side}}) \cap E_i$$

The slow flow  $\varphi_i^{\text{slow}}$  on  $\dagger B_i$  is transverse to both  $\dagger B_i^a$  and  $\dagger B_i^b$  and these sets are in the boundary of  $\dagger B_i$ , the flow entering  $\dagger B_i$  through one of them and leaving through the other. We call  $\dagger B_i^{\text{in}}$  the entrance part and  $\dagger B_i^{\text{out}}$  the exit part of  $\dagger B_i$ . Similarly we identify  $\dagger B'_i{}^{\text{in}}$  and  $\dagger B'_i{}^{\text{out}}$  as parts of  $\dagger B'_i$ . Notice that these assignments make sense only relative to the flow on  $E_i$  and it may be that  $\Pi(\dagger B_i^{\text{in}}) = \Pi(\dagger B_{i-1}^{\text{out}})$ .

We define the time functions  $\sigma_i^{\text{in}}(z)$ ,  $\sigma_i^{\text{out}}(z)$ ,  $\tau_i^{\text{in}}(z)$ , and  $\tau_i^{\text{out}}(z)$  as follows:

- For  $z \in \Sigma_i$ , if  $\varphi_i^{\text{slow}}(z, [0, T_i(z)]) \cap \dagger B'_i \neq \emptyset$ , then let

$$\begin{aligned}\sigma_i^{\text{in}}(z) &= \inf\{t \mid \varphi_i^{\text{slow}}(z, t) \in \dagger B'_i\}; \\ \sigma_i^{\text{out}}(z) &= \sup\{t \mid \varphi_i^{\text{slow}}(z, t) \in \dagger B'_i\}.\end{aligned}$$

- For  $z \in \Sigma_i$ , if  $\varphi_i^{\text{slow}}(z, [0, T_i(z)]) \cap \dagger B_i \neq \emptyset$ , then let

$$\begin{aligned}\tau_i^{\text{in}}(z) &= \inf\{t \mid \varphi_i^{\text{slow}}(z, t) \in \dagger B_i\}; \\ \tau_i^{\text{out}}(z) &= \sup\{t \mid \varphi_i^{\text{slow}}(z, t) \in \dagger B_i\}.\end{aligned}$$

We now assume that

**(H4)** the time functions  $\sigma_i^{\text{in}}(z)$ ,  $\sigma_i^{\text{out}}(z)$ ,  $\tau_i^{\text{in}}(z)$ , and  $\tau_i^{\text{out}}(z)$  can be extended to all  $z \in \Sigma_i$  such that

- (1) if  $\varphi_i^{\text{slow}}(z, [0, T_i(z)]) \cap \dagger B'_i = \emptyset$ , then  $\sigma_i^{\text{in}}(z) = \sigma_i^{\text{out}}(z) \geq 0$ ;
- (2) if  $\varphi_i^{\text{slow}}(z, [0, T_i(z)]) \cap \dagger B_i = \emptyset$ , then  $\tau_i^{\text{in}}(z) = \tau_i^{\text{out}}(z) \leq T_i(z)$ ;
- (3) they are all continuous functions on  $\Sigma_i$ .

Observe that if such extension is possible, then these time functions automatically satisfy

$$0 \leq \sigma_i^{\text{in}}(z) \leq \sigma_i^{\text{out}}(z) \leq \tau_i^{\text{in}}(z) \leq \tau_i^{\text{out}}(z) \leq T_i(z).$$

We set

$$\begin{aligned}\dagger U_i &:= \bigcup_{z \in \Sigma_i} \varphi_i^{\text{slow}}(z, [\sigma_i^{\text{in}}(z), \tau_i^{\text{out}}(z)]), \\ \widetilde{\dagger U}_i &:= \bigcup_{z \in \Sigma_i} \varphi_i^{\text{slow}}(z, [\sigma_i^{\text{out}}(z), \tau_i^{\text{in}}(z)]).\end{aligned}\tag{5.2}$$

We observe that by definition

$$\dagger U_i = \widetilde{\dagger U}_i \cap \dagger B_i \cup \dagger B'_i.$$

Define

$$\begin{aligned}\dagger U_i^{\text{in}} &:= \{\varphi_i^{\text{slow}}(z, \sigma_i^{\text{in}}(z)) \mid z \in \Sigma_i\} \\ \dagger U_i^{\text{out}} &:= \{\varphi_i^{\text{slow}}(z, \tau_i^{\text{out}}(z)) \mid z \in \Sigma_i\} \\ \dagger U_i^{\text{side}} &:= \text{cl}(\partial \dagger U_i \setminus (\dagger U_i^{\text{in}} \cup \dagger U_i^{\text{out}})) \\ \widetilde{\dagger U}_i^{\text{in}} &:= \{\varphi_i^{\text{slow}}(z, \sigma_i^{\text{out}}(z)) \mid z \in \Sigma_i\} \\ \widetilde{\dagger U}_i^{\text{out}} &:= \{\varphi_i^{\text{slow}}(z, \tau_i^{\text{in}}(z)) \mid z \in \Sigma_i\}\end{aligned}$$

Furthermore, define

$$\begin{aligned}\dagger V_i^+ &:= \text{cl}\{\varphi_i^{\text{slow}}(z, t) \mid z \in \Sigma_i, t \in [0, T_i(z)], \varphi_i^{\text{slow}}(z, [0, T_i(z)]) \cap \dagger B'_i = \emptyset\} \cap \dagger U_i \\ \dagger V_i^- &:= \text{cl}\{\varphi_i^{\text{slow}}(z, t) \mid z \in \Sigma_i, t \in [0, T_i(z)], \varphi_i^{\text{slow}}(z, [0, T_i(z)]) \cap \dagger B_i = \emptyset\} \cap \dagger U_i.\end{aligned}$$

See Figure 7.

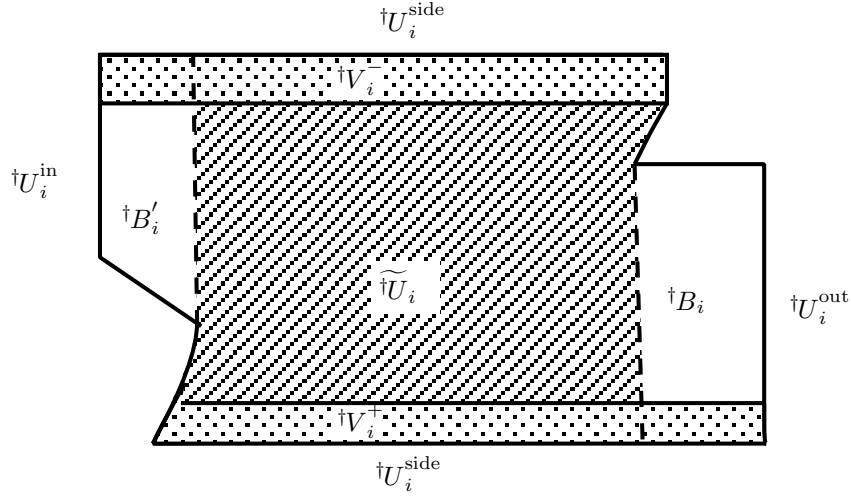

Figure 7: The set  $\dagger U_i$  and other relevant sets. The shape of the set  $\dagger U_i$  matches Figure 3.

**Remark 5.2** By the continuity of functions  $\tau_i^{\text{out}}(z)$  and  $\tau_i^{\text{in}}(z)$ , for all  $z \in \Sigma_i \cap \dagger V_i^-$  we have  $\tau_i^{\text{out}}(z) = \tau_i^{\text{in}}(z)$ . It follows that for all such  $z$ , if  $\varphi_i^{\text{slow}}(z, t)$  reaches boundary  $\dagger U_i^{\text{out}}$  the flow strictly exits  $\dagger U_i$ . Similarly, the continuity of  $\sigma_i^{\text{out}}(z)$  and  $\sigma_i^{\text{in}}(z)$ , implies that for all  $z \in \Sigma_i \cap \dagger V_i^+$  we have  $\sigma_i^{\text{out}}(z) = \sigma_i^{\text{in}}(z)$  and thus for  $z \in \Sigma_i \cap \dagger V_i^+$ , if  $\varphi_i^{\text{slow}}(z, t) \in \dagger U_i^{\text{in}}$  then the flow strictly enters  $\dagger U_i$ .

Let

$$\dagger \mathcal{U}_i := \Pi(\dagger U_i), \quad \dagger \mathcal{V}_i^\pm := \Pi(\dagger V_i^\pm)$$

and similarly with the other sets: by script letters we will denote a projection  $\Pi$  of the unscripted objects.

Recall that a subset  $C$  of a slow manifold  $M$  is a *cap*, if it is an isolating block under the slow flow  $\varphi^{\text{slow}}$  on  $M$ . Let  $C^-$  denote the exit set of a cap  $C$  under the slow flow  $\varphi^{\text{slow}}$ . Let  $B_r(A)$  denote an  $r$ -neighborhood of a set  $A$ . Recall that we defined boxes in the Introduction.

**Definition 5.3** A collection  $\{E_i\}_{i=0}^I$  of slow sheets with  $E_0 = E_I$ , corresponding sets  $\dagger U_i, \dagger B_i, \dagger B'_i \subset E_i$  and sets  $\dagger V_i^\pm \subset \dagger U_i$ , together with a collection of boxes  $\{\dagger \mathcal{B}_i \mid i = 1, \dots, I\}$  form a *periodic corridor* if

- (1)  $\dagger \mathcal{B}_i = \Pi(\dagger \mathcal{B}_i)$  for all  $i$ ;
- (2) For each  $i$  there is an  $r > 0$  such that

$$\dagger \mathcal{B}_i^{\text{side}} \setminus \dagger \mathcal{U}_i^{\text{side}} \subset \dagger \mathcal{V}_{i-1}^- \quad (5.3)$$

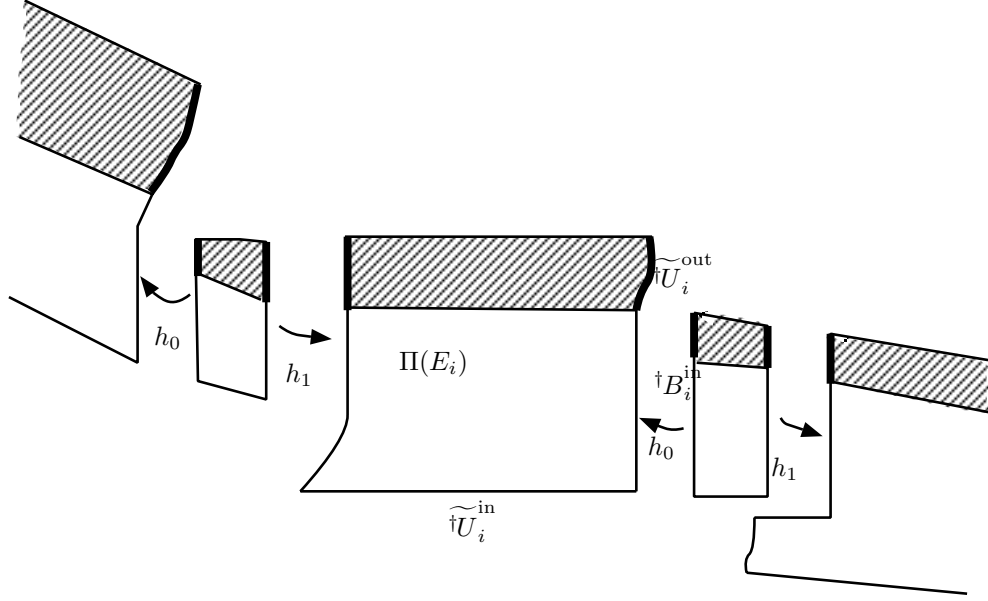

Figure 8: Homotopy equivalences.

$$\dagger U_i^{\text{side}} \subset \text{int}_{\dagger U_i} \dagger V_i^+ \cup \text{int}_{\dagger U_i} \dagger V_i^-; \quad (5.4)$$

- (3) Let  $\dagger \mathcal{B}_i^{\text{in}} := \Pi(\dagger B_i^{\text{in}})$  and  $\dagger \mathcal{B}_i^{\text{out}} := \Pi(\dagger B_{i-1}^{\text{out}})$ . For each  $i = 1, \dots, I$  there are homotopy equivalences of pairs

$$\begin{aligned} h_0 : (\dagger \mathcal{B}_i^{\text{in}}, \dagger \mathcal{B}_i^{\text{in}} \cap \dagger \mathcal{V}_{i-1}^-) &\hookrightarrow (\widetilde{\dagger \mathcal{U}}_i^{\text{out}}, \widetilde{\dagger \mathcal{U}}_i^{\text{out}} \cap \dagger \mathcal{V}_i^-), \\ h_1 : (\dagger \mathcal{B}_i^{\text{out}}, \dagger \mathcal{B}_i^{\text{out}} \cap \dagger \mathcal{V}_{i-1}^-) &\hookrightarrow (\widetilde{\dagger \mathcal{U}}_{i-1}^{\text{in}}, \widetilde{\dagger \mathcal{U}}_{i-1}^{\text{in}} \cap \dagger \mathcal{V}_{i-1}^-). \end{aligned} \quad (5.5)$$

See Figure 8.

**Definition 5.4** A collection  $\{E_i\}_{i=0}^I$  of slow sheets, corresponding sets  $\dagger U_i \subset E_i$ ,  $\dagger B_i, \dagger B'_i \subset E_i$  and sets  $\dagger V_i^\pm \subset \dagger U_i$ , together with a collection of boxes  $\{\dagger \mathcal{B}_i \mid i = 1, \dots, I\}$  and a pair of caps  $\dagger C_A$  and  $\dagger C_R$ , such that  $\dagger C_A \cap \dagger U_0^{\text{out}} \neq \emptyset$  and  $\dagger C_R \cap \dagger U_I^{\text{in}} \neq \emptyset$ , form a *heteroclinic corridor*, if they satisfy all the condition for a periodic corridor, and, in addition, there are homotopy equivalences

$$\begin{aligned} (\dagger C_R \cap \dagger \mathcal{U}_I^{\text{in}}, \dagger C_R^-) &\hookrightarrow (\dagger \mathcal{U}_I^{\text{in}}, \dagger \mathcal{U}_I^{\text{in}} \cap \dagger \mathcal{V}_I^-) \\ (\dagger \mathcal{U}_0^{\text{out}}, \dagger \mathcal{U}_0^{\text{out}} \cap \dagger \mathcal{V}_0^-) &\hookrightarrow (\dagger C_A \cap \dagger \mathcal{U}_0^{\text{out}}, \dagger C_A^-). \end{aligned} \quad (5.6)$$

**Remark 5.5** For heteroclinic corridor the two slow sheets  $E_0$  and  $E_I$  must be treated slightly differently. In  $E_0$ , since there is no shaft  $\dagger \mathcal{R}_{-1}$ , there is no set

$\dagger B_0$  and we define  $T_0(x) := \tau_0^{\text{in}}(x) = \tau_0^{\text{out}}(x)$  for all  $x \in \Sigma_i$ . Similarly, there is no set  $\dagger B'_I \subset E_I$  and so we set  $\sigma_I^{\text{in}}(x) = \sigma_I^{\text{out}}(x) = 0$ .

## 5.1 Main technical results

The goal of this subsection is to construct a singular isolating neighborhood for periodic and heteroclinic corridors and formulate two Theorems, which will allow us to prove Theorem 1.7 and Theorem 1.9. We will adhere strictly to the notation of Appendix A, concerning the singular index theory.

We begin by considering periodic and heteroclinic corridors. Recall that they consist of a collection of slow sheets  $\{E_i\}_{i=0,\dots,I}$ , sets  $\dagger U_i, \dagger V_i^\pm, \dagger B_i \subset E_i$  and a collection of boxes  $\{\dagger \mathbf{B}_i\}_{i=1,\dots,I}$ . In the case of heteroclinic corridor, we also have caps  $\dagger C_R$  and  $\dagger C_A$ .

Let

$$\dagger \mathbf{U}_i := [-r, r]^k \times \dagger U_i, \quad (5.7)$$

where  $r$  is selected in such a way that

$$([-r, r]^k \times \dagger B_i) \cup ([-r, r]^k \times \dagger B'_{i-1}) \subset \dagger \mathbf{B}_i$$

for all  $i$ . We also let

$$\dagger \mathbf{C}_A := [-r, r]^k \times \dagger C_A, \quad \dagger \mathbf{C}_R := [-r, r]^k \times \dagger C_R.$$

We are ready to define singular isolating neighborhood. For a periodic corridor, let

$$\dagger \mathbf{N} := \bigcup_{i=0}^I \dagger \mathbf{U}_i \cup \bigcup_{i=1}^I \dagger \mathbf{B}_i,$$

and for a heteroclinic corridor, let

$$\dagger \mathbf{N} := \bigcup_{i=0}^I \dagger \mathbf{U}_i \cup \bigcup_{i=1}^I \dagger \mathbf{B}_i \cup \dagger \mathbf{C}_R \cup \dagger \mathbf{C}_A.$$

We are ready for main technical results of this paper.

**Theorem 5.6** *Let  $\{E_i\}_{i=0,\dots,I}$  with  $E_0 = E_I$  be a periodic corridor. Then we have the following:*

- (1) *If  $r > 0$  chosen sufficiently small,  $\dagger \mathbf{N}$  is an isolating neighborhood for  $\varphi^\epsilon$  for sufficiently small  $\epsilon > 0$ ;*
- (2) *Assume furthermore that for each  $i = 1, \dots, I$ ,*

$$CH^j(M(1, i); \mathbb{Z}_2) \cong \begin{cases} \mathbb{Z}_2 & \text{if } j = s; \\ 0 & \text{otherwise} \end{cases}$$

and for all  $i = 0, \dots, I$

$$H^j(\dagger U_i, \dagger V_i^-; \mathbb{Z}_2) \cong \begin{cases} \mathbb{Z}_2 & \text{if } j = p, p+1; \\ 0 & \text{otherwise.} \end{cases}$$

If  $T_{\dagger \mathbf{B}_i}^*(2, 1)$  is an isomorphism for all  $i = 1, \dots, I$ , then

$$CH^j(\text{Inv}(\dagger \mathbf{N}, \varphi^\epsilon); \mathbb{Z}_2) \cong \begin{cases} \mathbb{Z}_2 & \text{if } j = s+p, s+p+1; \\ 0 & \text{otherwise} \end{cases}.$$

**Theorem 5.7** *Let  $\{E_i\}_{i=0, \dots, I}$  with caps  $\dagger C_A$  and  $\dagger C_R$  be a heteroclinic corridor. Then we have*

- (1) For  $r > 0$  sufficiently small,  $\dagger \mathbf{N}$  is an isolating neighborhood for  $\varphi^\epsilon$ ;
- (2)  $(\text{Inv}(\dagger C_R, \varphi^\epsilon), \text{Inv}(\dagger C_A, \varphi^\epsilon))$  gives an attractor-repeller decomposition for  $\text{Inv}(\dagger \mathbf{N}, \varphi^\epsilon)$ ;
- (3) If  $T_{\dagger \mathbf{B}_i}^*(2, 1) \neq 0$  for all  $i = 1, \dots, I$  and

$$\begin{aligned} CH^{*+1}(\text{Inv}(\dagger C_R)) &\cong H^*(\dagger C_R \cap \dagger U_I, \dagger C_R \cap \dagger V_I^-), \\ CH^*(\text{Inv}(\dagger C_A)) &\cong H^*(\dagger C_A \cap \dagger U_0, \dagger C_A \cap \dagger V_0^-), \end{aligned} \quad (5.8)$$

then

$$CH^*(\text{Inv}(\dagger \mathbf{N}, \varphi^\epsilon)) \cong CH^*(\text{Inv}(\dagger C_A, \varphi^\epsilon)) \oplus CH^*(\text{Inv}(\dagger C_R, \varphi^\epsilon)).$$

## 5.2 Singular isolating neighborhood

The goal is to show that  $\dagger \mathbf{N}$  is a singular isolating neighborhood. Perhaps the first observation that needs to be made is that  $\dagger \mathbf{N}$  is not an isolating neighborhood. To see this let

$$S := \text{Inv}(\dagger \mathbf{N}, \varphi^0)$$

and

$$S_\partial := S \cap \partial \dagger \mathbf{N}.$$

Observe that  $(x, y) \in \dagger U_i \cap \partial \dagger \mathbf{N}$  then  $\{x\}$  is an invariant set of the flow  $\psi^y$ ; thus  $z := (x, y) \in S_\partial$ .

Let  $\dagger Q_i \subset \dagger U_i$  be a set such that if  $y \in \dagger Q_i$  there is a connecting orbit from the  $M_y(2, i)$  to  $M_y(1, i)$  lying in the boundary  $\partial \dagger \mathbf{N}$ . Then by definition of  $\dagger \mathbf{N}$ , we must have that  $\dagger Q_i \subset \partial \dagger U_i$ , and since  $\Pi(\dagger \mathbf{B}_i) = \dagger \mathcal{B}_i$  we also have  $\dagger Q_i \subset \partial \dagger \mathcal{B}_i$ . Therefore

$$\dagger Q_i \subset \partial \dagger \mathcal{B}_i \cap \partial \dagger U_i.$$

Note that  $\partial \dagger \mathcal{B}_i = \dagger \mathcal{B}_i^{\text{in}} \cup \dagger \mathcal{B}_i^{\text{out}} \cup \dagger \mathcal{B}_i^{\text{side}}$  and  $\partial \dagger U_i = \dagger U_i^{\text{in}} \cup \dagger U_i^{\text{out}} \cup \dagger U_i^{\text{side}}$ .

From definition of these sets it follows that

$$\partial \dagger \mathcal{B}_i \cap \partial \dagger U_i = (\dagger \mathcal{B}_i^{\text{side}} \cap \dagger U_i^{\text{side}}) \cup \dagger \mathcal{B}_i^{\text{out}} \cup (\dagger \mathcal{B}_i^{\text{side}} \cap \dagger U_i^{\text{out}}).$$



By definition of the set  $\dagger\mathcal{B}_i^{\text{out}}$  there are no connecting orbits in  $S_y$  for  $y \in \dagger\mathcal{B}_i^{\text{out}}$  and so

$$\dagger\mathcal{Q}_i \subset (\dagger\mathcal{B}_i^{\text{side}} \cap \dagger\mathcal{U}_i^{\text{side}}) \cup (\dagger\mathcal{B}_i^{\text{side}} \cap \dagger\mathcal{U}_i^{\text{out}}).$$

It follows from (5.4) that  $\dagger\mathcal{U}_i^{\text{side}} \subset \dagger\mathcal{V}_i^+ \cup \dagger\mathcal{V}_i^-$ . Note however, that if  $w \in \dagger\mathcal{U}_i^{\text{side}} \cap \dagger\mathcal{V}_i^-$  then

$$w = \varphi_i^{\text{slow}}(z, t) \quad z \in \Sigma_i \text{ and } t \leq \tau_i^{\text{in}}(z) = \tau_i^{\text{out}}(z),$$

where  $\tau_i^{\text{in}}(z) = \tau_i^{\text{out}}(z)$  by Remark 5.2. From definition of  $\dagger\mathcal{B}_i^{\text{side}}$  if  $y \in \dagger\mathcal{B}_i^{\text{side}}$  then

$$w = \varphi_i^{\text{slow}}(z, t) \quad z \in \Sigma_i \text{ and } t > \tau_i^{\text{in}}(z).$$

Thus it follows that  $\dagger\mathcal{B}_i^{\text{side}} \cap \dagger\mathcal{U}_i^{\text{side}} \cap \dagger\mathcal{V}_i^- = \emptyset$  and

$$\dagger\mathcal{B}_i^{\text{side}} \cap \dagger\mathcal{U}_i^{\text{side}} \subset \dagger\mathcal{V}_i^+.$$

Finally, it follows from (5.3) that

$$\dagger\mathcal{B}_i^{\text{side}} \cap \dagger\mathcal{U}_i^{\text{out}} \subset \dagger\mathcal{V}_{i-1}^-,$$

which implies

$$\dagger\mathcal{Q}_i \subset \dagger\mathcal{V}_i^+ \cup \dagger\mathcal{V}_{i-1}^-.$$

The connecting orbit from the  $M_y(2, i)$  to  $M_y(1, i)$  for  $y \in \dagger\mathcal{Q}_i$  lies on the boundary of  $\dagger\mathbf{N}$  and hence this connecting orbit is a part of  $S_\partial$ . Set  $C_{i,y}$  be the set of connecting orbits connecting  $M_y(2, i)$  to  $M_y(1, i)$ , lying in the boundary of  $\dagger\mathbf{N}$ . Note that  $\dagger U_i \cap \partial \dagger\mathbf{N} = \partial \dagger U_i$ . Therefore

$$S_\partial := \bigcup_{i=1}^I \partial \dagger U_i \cup \bigcup_{i=1}^I \bigcup_{y \in \dagger\mathcal{Q}_i} C_{i,y}. \quad (5.9)$$

Since this set is not empty,  $\dagger\mathbf{N}$  is not an isolating neighborhood under  $\psi^Y$ .

Now we show that  $\dagger\mathbf{N}$  is a singular isolating neighborhood. We shall first deal with a periodic corridor.

**Periodic corridor.** Recall, that we denote by  $S_\partial^-$  the set of slow exit points, by  $S_\partial^+$  the set of slow entrance points.

Note that the first part of the set  $S_\partial$  decomposes as

$$\partial \dagger U_i = \dagger U_i^{\text{side}} \cup \dagger U_i^{\text{in}} \cup \dagger U_i^{\text{out}}.$$

**Lemma 5.8** *For a periodic corridor,*

$$\mathbf{S}^- := \bigcup_{i=0}^I \dagger V_i^- \cup \bigcup_{i=1}^I \bigcup_{y \in \dagger\mathcal{Q}_i \cap \dagger\mathcal{V}_{i-1}^-} C_{i,y} \cup \bigcup_{i=0}^I \dagger U_i^{\text{out}}$$

is a set of  $C$ -slow exit points, and

$$\mathbf{S}^+ := \bigcup_{i=0}^I \dagger U_i^{\text{in}} \cup \bigcup_{i=0}^I (\dagger U_i^{\text{side}} \setminus \dagger V_i^-) \cup \bigcup_{i=1}^I \bigcup_{y \in \dagger \mathcal{Q}_i \setminus \dagger \mathcal{V}_{i-1}^-} C_{i,y}$$

is a set of  $C$ -slow entrance points.

Comparing to (5.9) this implies  $S_\partial \subset \mathbf{S}^- \cup \mathbf{S}^+$ , and therefore  $\dagger \mathbf{N}$  is a singular isolating neighborhood.

*Proof.* See Appendix B.  $\square$

**Heteroclinic corridor.** Recall from Definition 1.8 and Definition 5.4 that  $\dagger C_R$  and  $\dagger C_A$  are isolating blocks in the corresponding slow flow and  $\dagger C_R^-$  and  $\dagger C_A^-$  are their corresponding exits sets. Let

$$\dagger C_R^L := \dagger C_R^- \setminus \dagger U_I \quad \text{and} \quad \dagger C_A^L := \dagger C_A^- \quad (5.10)$$

and let

$$\dagger C_R^E := (\dagger C_R \cap \partial \dagger \mathbf{N}) \setminus \dagger C_R^L \quad \text{and} \quad \dagger C_A^E := (\dagger C_A \cap \partial \dagger \mathbf{N}) \setminus \dagger C_A^L.$$

**Lemma 5.9** *For a heteroclinic corridor*

$$\begin{aligned} \mathbf{S}^- := & (\dagger C_R^L \cap \partial \dagger \mathbf{N}) \cup (\dagger C_A^L \cap \partial \dagger \mathbf{N}) \cup \bigcup_{i=0}^I \dagger V_i^- \\ & \cup \bigcup_{i=1}^I \bigcup_{y \in \dagger \mathcal{Q}_i \cap \dagger \mathcal{V}_{i-1}^-} C_{i,y} \cup \bigcup_{i=1}^I \dagger U_i^{\text{out}} \cup (\dagger U_0^{\text{out}} \setminus \dagger C_A) \end{aligned}$$

is a set of  $C$ -slow exit points, and

$$\begin{aligned} \mathbf{S}^+ := & \dagger C_R^E \cup \dagger C_A^E \cup \bigcup_{i=0}^{I-1} \dagger U_i^{\text{in}} \cup (\dagger U_I^{\text{in}} \setminus \dagger C_R) \\ & \cup \bigcup_{i=0}^I (\dagger U_i^{\text{side}} \setminus \dagger V_i^-) \cup \bigcup_{i=1}^I \bigcup_{y \in \dagger \mathcal{Q}_i \setminus \dagger \mathcal{V}_{i-1}^-} C_{i,y} \end{aligned}$$

is a set of  $C$ -slow entrance points.

Comparing to (5.9) this implies  $S_\partial \subset \mathbf{S}^- \cup \mathbf{S}^+$ , and therefore  $\dagger \mathbf{N}$  is a singular isolating neighborhood.

*Proof.* See Appendix B.  $\square$

### 5.2.1 Immediate exit set

The next step is to identify the immediate exit set  $\dagger\mathbf{N}^-$  and then construct the set  $\dagger\mathbf{L}$ .

Since  $M_i$  is normally hyperbolic there are Fenichel coordinates  $(\xi, \eta)$  in the neighborhood of the slow manifold  $M_i$  ([6]). In these coordinates the flow  $\psi^Y$  has the form

$$\dot{\xi}_1 = A\xi_1 + f_1(\xi, \eta), \quad \dot{\xi}_2 = B\xi + f_2(\xi, \eta),$$

where  $\xi = (\xi_1, \xi_2)$ , eigenvalues of  $A$  have negative real part and eigenvalues of  $B$  have positive real part. Functions  $f_1$  and  $f_2$  contain higher order terms. We denote by  $s$  the size of square matrix  $B$ .

In the coordinates  $(\xi_1, \xi_2, \eta)$  the immediate exit set  $\dagger\mathbf{U}_i^-$  from the set  $\dagger\mathbf{U}_i$  has the form

$$\dagger\mathbf{U}_i^- := \partial[-r, r]^s \times [-r, r]^{k-s} \times \dagger\mathbf{U}_i. \quad (5.11)$$

Similarly, the immediate exit set from the caps  $\dagger\mathbf{C}_R$  and  $\dagger\mathbf{C}_A$  have the form

$$\dagger\mathbf{C}_*^- := \partial[-r, r]^s \times [-r, r]^{k-s} \times \dagger\mathbf{C}_*$$

for  $* = A, R$ .

Finally, let  $\dagger\mathbf{B}_i^-$  be the immediate exit set of the box  $\dagger\mathbf{B}_i$  and let  $\dagger\mathbf{N}_y := \dagger\mathbf{N} \cap (\mathbb{R}^k \times \{y\})$ .

**Lemma 5.10** *Given a singular isolating neighborhood  $\dagger\mathbf{N}$  for a periodic corridor, the immediate exit set of  $\dagger\mathbf{N}$  under  $\varphi^0$  is:*

$$\dagger\mathbf{N}^- = \left[ \left( \bigcup_{i=0}^I \dagger\mathbf{U}_i^- \right) \cup \left( \bigcup_{i=1}^I \dagger\mathbf{B}_i^- \right) \right] \setminus \bigcup_{i=1}^I \left( \dagger\mathbf{B}_i \cap \left( \dagger\mathbf{U}_i^- \cup \dagger\mathbf{U}_{i+1}^- \right) \right).$$

*Proof.* Since we are working with the flow  $\varphi^0$ , it is sufficient to consider  $\psi_y$  for each relevant value of  $y$ .

First consider a set  $\dagger\mathbf{U}_i$ . Choose  $y \in \dagger\mathbf{U}_i$ . By normal hyperbolicity, for sufficiently small  $q$  the set  $\dagger\mathbf{U}_y$  is an isolating block and by definition of  $\dagger\mathbf{N}^-$  and the choice of Fenichel coordinates we have  $x \in \dagger\mathbf{U}_y \cap \dagger\mathbf{N}^-$  if and only if  $x \in \dagger\mathbf{U}_y^-$ .

Now we assume  $y \in \dagger\mathbf{B}_i$ . Then  $\dagger\mathbf{N}_y \subset \dagger\mathbf{B}_y$  and by definition of  $\dagger\mathbf{N}^-$ ,  $x \in \dagger\mathbf{B}_y$  is in  $\dagger\mathbf{N}^-$  if and only if  $x \in \dagger\mathbf{B}_y^-$ .  $\square$

A similar argument, in which one only needs to consider, in addition, the caps, leads to the following lemma.

**Lemma 5.11** *For a singular isolating neighborhood  $\dagger\mathbf{N}$  for a heteroclinic corridor, the immediate exit set of  $\dagger\mathbf{N}$  under  $\varphi^0$  is:*

$$\dagger\mathbf{N}^- = \left[ \left( \bigcup_{i=0}^I \dagger\mathbf{U}_i^- \right) \cup \left( \bigcup_{i=1}^I \dagger\mathbf{B}_i^- \right) \cup \dagger\mathbf{C}_A^- \cup \dagger\mathbf{C}_R^- \right] \setminus \bigcup_{i=1}^I \left( \dagger\mathbf{B}_i \cap \left( \dagger\mathbf{U}_i^- \cup \dagger\mathbf{U}_{i+1}^- \right) \right).$$

### 5.3 Singular index pair

We denote the unstable manifold of a set  $A$  in set  $X$  by  $W_X^u(A)$ .

**Proposition 5.12** *Given a singular isolating neighborhood  $\dagger\mathbf{N}$  for a periodic corridor  $(\dagger\mathcal{U}, \dagger\mathcal{V})$ , let*

$$\dagger\mathbf{L} := \rho(\text{cl}(\dagger\mathbf{N}^-), \dagger\mathbf{N}, \varphi^0) \cup \left( \bigcup_{i=1}^I W_{\dagger\mathbf{B}_i}^u(\dagger U_i^{\text{out}}) \right) \cup \left( \bigcup_{i=0}^I \bigcup_{y \in \dagger\mathcal{V}_i^-} N_y \right).$$

*Then there is a pair  $(\dagger\bar{\mathbf{N}}, \dagger\bar{\mathbf{L}})$  homotopically equivalent to the pair  $(\dagger\mathbf{N}, \dagger\mathbf{L})$  such that  $(\dagger\bar{\mathbf{N}}, \dagger\bar{\mathbf{L}})$  is a singular index pair.*

*Proof.* See Appendix B. □

**Proposition 5.13** *Given a singular isolating neighborhood  $\dagger\mathbf{N}$  for a heteroclinic corridor, let*

$$\begin{aligned} \dagger\mathbf{L} := & \rho(\text{cl}(\dagger\mathbf{N}^-), \dagger\mathbf{N}, \varphi^0) \cup \bigcup_{y \in \text{cl}(\dagger C_R^L)} \dagger\mathbf{N}_y \cup \bigcup_{y \in \dagger C_A^L} \dagger\mathbf{N}_y \\ & \cup \left( \bigcup_{i=1}^I W_{\dagger\mathbf{B}_i}^u(\dagger U_i^{\text{out}}) \right) \cup \left( \bigcup_{i=0}^I \bigcup_{y \in \dagger\mathcal{V}_i^-} \dagger\mathbf{N}_y \right). \end{aligned}$$

*Then there is a pair  $(\dagger\bar{\mathbf{N}}, \dagger\bar{\mathbf{L}})$ , homotopically equivalent to the pair  $(\dagger\mathbf{N}, \dagger\mathbf{L})$ , such that  $(\dagger\bar{\mathbf{N}}, \dagger\bar{\mathbf{L}})$  is a singular index pair.*

*Proof.* See Appendix B. □

Let

$$\dagger\mathbf{L}^{\text{slow}} := \bigcup_{i=0}^I \bigcup_{y \in \dagger\mathcal{V}_i^-} \dagger\mathbf{N}_y \tag{5.12}$$

and

$$\dagger\mathbf{L}^{\text{fast}} := \rho(\text{cl}(\dagger\mathbf{N}^-), \dagger\mathbf{N}, \varphi^0) \cup \left( \bigcup_{i=1}^I W_{\dagger\mathbf{B}_i}^u(\dagger U_i^{\text{out}}) \right). \tag{5.13}$$

### 5.4 Verification of assumptions of local models

Our first step is to define a collection of sets  $\mathcal{U}_i$ ,  $i = 1, \dots, I$  from the sets  $\dagger\mathcal{U}_i$ ,  $i = 0, \dots, I$ .

Select for each  $i = 1, \dots, I$  and each  $z \in \Sigma_i$  a value  $\alpha_i(z) \in (\sigma_i^{\text{out}}(z), \tau_i^{\text{in}}(z))$  such that the function  $\alpha_i : \Sigma \rightarrow \mathbb{R}$  is continuous. For heteroclinic case we need

to treat  $\dagger U_0$  and  $\dagger U_I$  differently. We set  $\alpha_0(z) := T_0(z)$  and  $\alpha_I(z) := 0$ . Let

$$\begin{aligned}\dagger U_i^\alpha &:= \{\varphi_i^{\text{slow}}(z, \alpha_i(z)) \mid z \in \Sigma_i\} \\ \dagger U_i^{\text{top}} &:= \{\varphi_i^{\text{slow}}(z, t) \mid z \in \Sigma_i, t \in [\alpha_i(z), \tau_i^{\text{in}}(z)]\} \\ \dagger U_i^{\text{bot}} &:= \{\varphi_i^{\text{slow}}(z, t) \mid z \in \Sigma_i, t \in [\sigma_i^{\text{out}}(z), \alpha_i(z)]\}.\end{aligned}$$

Observe that both  $\dagger U_i^{\text{top}}$  and  $\dagger U_i^{\text{bot}}$  are subsets of  $\widetilde{\dagger U}_i$ . Keeping up our previous notational agreements, we set

$$\dagger V_i^{*,\pm} := \dagger V_i^\pm \cap \dagger U^*$$

where  $*$  =  $\alpha, \text{top}, \text{bot}$ , and by the corresponding script symbols we represent projection of these objects to the slow variable space  $\mathbb{R}^l$  under  $\Pi$ .

Let

$$\circ \mathcal{B}_i := \dagger \mathcal{B}_i$$

and

$$\circ \mathcal{U}_i^1 := (\dagger U_{i-1}^{\text{bot}} \sqcup \dagger \mathcal{B}_i) / \sim_1$$

be a disjoint union of  $\dagger \mathcal{U}_{i-1}^{\text{bot}}$  and  $\dagger \mathcal{B}_i$ , with some points identified by equivalence  $\sim_1$ . Let  $y \in \widetilde{\dagger \mathcal{U}}_{i-1}^{\text{in}}$  and  $y' \in \dagger \mathcal{B}_i^{\text{out}}$ . Then  $y \sim_1 y'$  if and only if  $h_1(y') = y$ , where  $h_1$  is a homotopy equivalence in (5.5). Similarly, let

$$\dagger \mathcal{U}_i^0 := (\dagger \mathcal{U}_i^{\text{top}} \sqcup \dagger \mathcal{B}_i) / \sim_0$$

be a disjoint union of  $\dagger \mathcal{U}_i^{\text{top}}$  and  $\dagger \mathcal{B}_i$ , with some points identified by equivalence  $\sim_0$ : Let  $z \in \widetilde{\dagger \mathcal{U}}_i^{\text{out}}$  and  $w \in \dagger \mathcal{B}_i^{\text{in}}$ . Then  $z \sim_0 w$  if and only if  $h_0(w) = z$ , where  $h_0$  is a homotopy equivalence in (5.5).

Let

$$\begin{aligned}\circ \mathcal{V}_i^1 &:= [(\dagger \mathcal{V}_{i-1}^{\text{bot}-} \sqcup (\dagger \mathcal{B}_i \cap \dagger \mathcal{V}_i^-))] / \sim_1 \\ \circ \mathcal{V}_i^0 &:= [(\dagger \mathcal{V}_i^{\text{top}-} \sqcup (\dagger \mathcal{B}_i \cap \dagger \mathcal{V}_i^-))] / \sim_0.\end{aligned}$$

**Lemma 5.14** *For each  $i = 1, \dots, I$ , the collection  $(\circ \mathcal{U}_i^0, \circ \mathcal{U}_i^1, \circ \mathcal{V}_i^0, \circ \mathcal{V}_i^1, \circ \mathcal{B}_i)$  is a slow local model.*

*Proof.* The first property is satisfied immediately by construction with  $h = \text{id}$ . To define required fibrations, we first observe that sets  $\dagger \mathcal{U}_i^{\text{top}}$  and  $\dagger \mathcal{U}_{i-1}^{\text{bot}}$  have natural fibrations given by slow flows  $\varphi_i^{\text{slow}}$  and  $\varphi_{i-1}^{\text{slow}}$ , respectively. Indeed, let us rescale time in the flow  $\varphi_i^{\text{slow}}$  in such a way that, for all  $z$ ,  $\alpha_i(z) = \alpha_i$  and  $\tau_i^{\text{in}}(z) = \beta'_i$  for some constant  $\beta'_i$ . Then the map  $p_0 : \dagger \mathcal{U}_i^{\text{top}} \rightarrow [\alpha_i, \beta'_i]$  given by

$$\Pi \circ \varphi_i^{\text{slow}}(z, t) \mapsto t$$

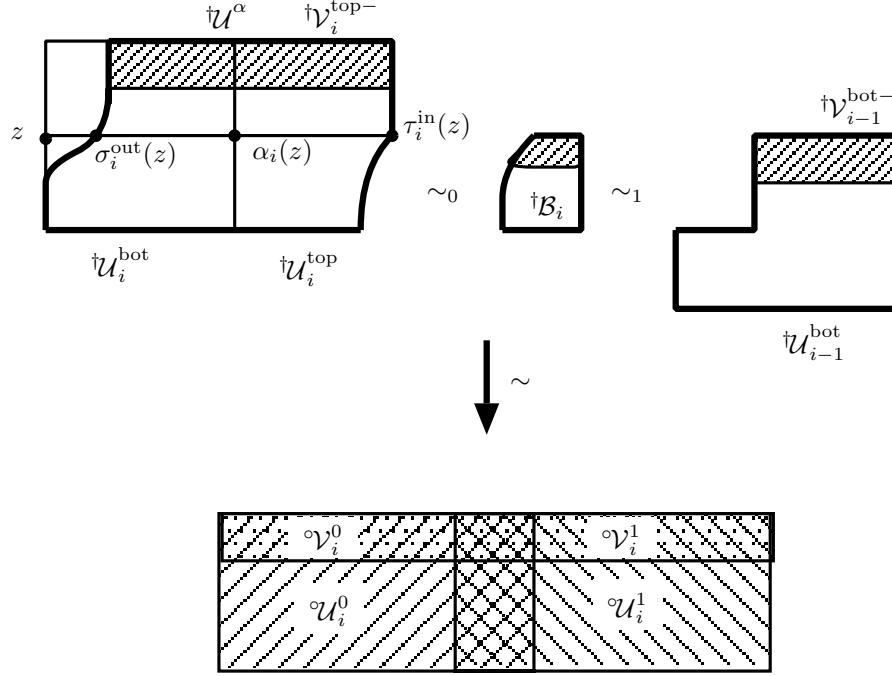

Figure 9: Construction of a local model from a corridor.

for  $z \in \Sigma_i$ , is a fibration.

Similarly, we rescale time in the flow  $\varphi_{i-1}^{\text{slow}}$  in such a way that, for all  $x$ ,  $\sigma_{i-1}^{\text{out}}(z) = \beta_i$  and  $\alpha_i(z) = \alpha'_i$ . Then the map  $p_1 : \dagger\mathcal{U}_{i-1}^{\text{bot}} \rightarrow [\beta_i, \alpha'_i]$  given by

$$\Pi \circ \varphi_{i-1}^{\text{slow}}(z, t) \mapsto t$$

for  $z \in \Sigma_{i-1}$ , is a fibration.

What remains to be done is to define a fibration  $p$  on the set  $\dagger\mathcal{B}_i$  in such a way that it seamlessly meshes with the  $p_0$  and  $p_1$  fibrations on  $\dagger\mathcal{U}_i^{\text{top}}$  and  $\dagger\mathcal{U}_{i-1}^{\text{bot}}$ . However, this is guaranteed by definition of the shaft  $\dagger\mathcal{R}_i$  which asserts the existence of such fibration for the set  $\dagger\mathcal{B}_i \subset \dagger\mathcal{R}_i$  and assumption **(H3)** which implies that this fibration meshes with fibrations on  $\dagger\mathcal{U}_i^{\text{top}}$  and  $\dagger\mathcal{U}_{i-1}^{\text{bot}}$ . Indeed, the pair  $(\widetilde{\dagger\mathcal{U}}_i^{\text{out}}, \widetilde{\dagger\mathcal{U}}_i^{\text{out}} \cap \dagger\mathcal{V}_i^-)$  is a fiber of a  $p$ -fibration of  $\dagger\mathcal{U}_i^{\text{top}}$  and  $(\dagger\mathcal{B}_i^{\text{in}}, \dagger\mathcal{B}_i^{\text{in}} \cap \dagger\mathcal{V}_{i-1}^-)$  is a fiber of a  $p$ -fibration of  $\dagger\mathcal{B}_i$ . The identification  $\sim_0$  identifies these two leaves. Similarly, the identification  $\sim_1$  identifies fiber  $(\widetilde{\dagger\mathcal{U}}_{i-1}^{\text{in}}, \widetilde{\dagger\mathcal{U}}_{i-1}^{\text{in}} \cap \dagger\mathcal{V}_{i-1}^-)$  of a  $p$ -fibration of  $\dagger\mathcal{U}_{i-1}^{\text{bot}}$  and the fiber  $(\dagger\mathcal{B}_{i-1}^{\text{out}}, \dagger\mathcal{B}_{i-1}^{\text{out}} \cap \dagger\mathcal{V}_{i-1}^-)$  of  $p$ -fibration of  $\dagger\mathcal{B}_i$ .

It follows that using the identifications  $\sim_0$  and  $\sim_1$  the  $p$ -fibrations of the individual sets join in a  $p$ -fibration of the union  $\circ\mathcal{U}_i$ .  $\square$

We extend the equivalence defined by  $\sim_0$  to a tube  $\dagger\mathbf{U}_i$ . If  $(x, y)$  and  $(x', y')$  are two points in  $\dagger\mathbf{U}_i$  we write

$$(x, y) \sim_2 (x', y'), \quad x, x' \in [-r, r]^k, y, y' \in \mathbb{R}^\ell$$

if and only if  $y \sim_0 y'$  and  $x = x'$ .

Similarly we define  $\sim_3$  for a tube  $\dagger\mathbf{U}_{i-1}$  using  $\sim_1$  for slow coordinate. Then let

$$\begin{aligned} \circ\mathbf{U}_i^1 &:= [(\dagger\mathbf{U}_{i-1} \cap \Pi^{-1}(\widetilde{\mathcal{U}}_{i-1}^{\text{top}})) \sqcup (\dagger\mathbf{U}_{i-1} \cap \dagger\mathbf{B}_i)] / \sim_2 \\ \circ\mathbf{U}_i^0 &:= [(\dagger\mathbf{U}_i \cap \Pi^{-1}(\widetilde{\mathcal{U}}_i^{\text{bot}})) \sqcup (\dagger\mathbf{U}_i \cap \dagger\mathbf{B}_i)] / \sim_3. \end{aligned}$$

Now let  $\circ\mathbf{L}_i$ ,  $\circ\mathbf{L}_i^{\text{slow}}$  and  $\circ\mathbf{L}_i^{\text{fast}}$  be the images of the sets  $\dagger\mathbf{L}$ ,  $\dagger\mathbf{L}^{\text{slow}}$  and  $\dagger\mathbf{L}^{\text{fast}}$ , respectively, in the above construction in the set  $\circ\mathbf{U}_i^0 \cup \circ\mathbf{B}_i \cup \circ\mathbf{U}_i^1$ . The map  $q_i : \circ\mathbf{U}_i^0 \cup \circ\mathbf{B}_i \cup \circ\mathbf{U}_i^1 \rightarrow \mathcal{U}_i$  is given by projection  $\Pi$  factored through the equivalences  $\sim_2$  and  $\sim_3$ . Finally, let

$$\begin{aligned} \circ\mathbf{U}_i^1 &:= [\dagger\mathcal{U}_{i-1}^{\text{bot}} \sqcup \dagger\mathbf{B}_i] / \sim_3, & \circ\mathbf{V}_i^1 &:= [\dagger\mathcal{V}_{i-1}^{\text{bot-}} \sqcup (\dagger\mathbf{B}_i \cap \dagger\mathcal{V}_{i-1}^-)] / \sim_3 \\ \circ\mathbf{U}_i^0 &:= [\dagger\mathcal{U}_i^{\text{top}} \sqcup \dagger\mathbf{B}_i] / \sim_2, & \circ\mathbf{V}_i^0 &:= [\dagger\mathcal{V}_i^{\text{top-}} \sqcap (\dagger\mathbf{B}_i \cap \dagger\mathcal{V}_{i-1}^-)] / \sim_2. \end{aligned}$$

**Lemma 5.15** *For each  $i$  the collection  $(\circ\mathbf{U}_i^0, \circ\mathbf{U}_i^1, \circ\mathbf{V}_i^0, \circ\mathbf{V}_i^1, \circ\mathbf{U}_i^0, \circ\mathbf{U}_i^1, \circ\mathbf{B}_i, \circ\mathbf{L}_i)$  with the map  $q_i$  is a local model.*

*Proof.* Observe that  $q_i^{-1}(y) = [-r, r]^k$  for all  $y \in \mathcal{U}_i \setminus \circ\mathbf{B}_i$  by construction of the tubes. For  $y \in \circ\mathbf{B}_i$  we have  $q_i^{-1}(y) = \circ\mathbf{B}_{i,y}$  which is a  $k$ -disc by definition of the box  $\circ\mathbf{B}_i$ . The rest of the first part of the assumptions of local model follows from the fact that  $\Pi|_{E_i}$  is a homeomorphism for each  $i$ .

A parametrized flow is defined naturally for our sets and they satisfy the second group of assumptions of a local model by the definition of the tubes and boxes.

Now we verify the third group of the assumptions. From definition (5.12) of  $\dagger\mathbf{L}^{\text{slow}}$  and the construction of the sets  $\dagger\mathbf{U}_i, \dagger\mathbf{V}_i$  using (5.5) it follows that

$$\circ\mathbf{L}_i^{\text{slow}} = q_i^{-1}(\circ\mathcal{V}_i).$$

The second part follows from definition (5.7) of  $\dagger\mathbf{U}_i$  and definition (5.11) of  $\dagger\mathbf{U}_i^-$ . We start the proof of the last condition by observing that

$$\begin{aligned} \dagger\mathcal{U}_i^{\text{out}} &= (\dagger\mathcal{U}_i^{\text{out}} \setminus \partial\dagger\mathbf{B}_i) \cup (\dagger\mathcal{U}_i^{\text{out}} \cap \partial\dagger\mathbf{B}_i) \\ &= (\dagger\mathcal{U}_i^{\text{out}} \setminus \partial\dagger\mathbf{B}_i) \cup (\dagger\mathcal{U}_i^{\text{out}} \cap \dagger\mathbf{B}_i^{\text{side}}) \cup \dagger\mathbf{B}_i^{\text{out}}, \end{aligned}$$

where we used the fact that  $\partial\dagger\mathbf{B}_i = \dagger\mathbf{B}_i^{\text{in}} \cup \dagger\mathbf{B}_i^{\text{side}} \cup \dagger\mathbf{B}_i^{\text{out}}$ , that  $\dagger\mathbf{B}_i^{\text{in}} \cap \dagger\mathcal{U}_i^{\text{out}} = \emptyset$  and that  $\dagger\mathbf{B}_i^{\text{out}} \subset \dagger\mathcal{U}_i^{\text{out}}$ .

**SubLemma 5.16** *From (5.3) in Definition 5.3, we have*

$$\dagger\mathcal{U}_i^{\text{out}} \subset (\dagger\mathcal{U}_i^{\text{out}} \setminus \partial\dagger\mathcal{B}_i) \cup \dagger\mathcal{B}_i^{\text{out}} \cup \dagger\mathcal{V}_{i-1}^-; \quad (5.14)$$

$$\widetilde{\dagger\mathcal{U}}_i^{\text{out}} \subset (\widetilde{\dagger\mathcal{U}}_i^{\text{out}} \setminus \partial\dagger\mathcal{B}_i) \cup \dagger\mathcal{B}_i^{\text{in}} \cup \dagger\mathcal{V}_{i-1}^-. \quad (5.15)$$

*Proof.* From  $\partial\dagger\mathcal{B}_i = \dagger\mathcal{B}_i^{\text{in}} \cup \dagger\mathcal{B}_i^{\text{side}} \cup \dagger\mathcal{B}_i^{\text{out}}$  and  $\dagger\mathcal{B}_i^{\text{out}} \subset \dagger\mathcal{U}_i^{\text{out}}$ , we have

$$\dagger\mathcal{U}_i^{\text{out}} \cap \partial\dagger\mathcal{B}_i \subset (\dagger\mathcal{U}_i^{\text{out}} \cap \dagger\mathcal{B}_i^{\text{side}}) \cup \dagger\mathcal{B}_i^{\text{out}},$$

where  $\dagger\mathcal{U}_i^{\text{out}} \cap \dagger\mathcal{B}_i^{\text{side}}$  is clearly a subset of  $\dagger\mathcal{B}_i^{\text{side}} \setminus \dagger\mathcal{U}_i^{\text{side}}$  which is assumed to be a subset of  $\dagger\mathcal{V}_{i-1}^-$  from (5.3). Therefore

$$\dagger\mathcal{U}_i^{\text{out}} = (\dagger\mathcal{U}_i^{\text{out}} \setminus \partial\dagger\mathcal{B}_i) \cup (\dagger\mathcal{U}_i^{\text{out}} \cap \partial\dagger\mathcal{B}_i) \subset (\dagger\mathcal{U}_i^{\text{out}} \setminus \partial\dagger\mathcal{B}_i) \cup \dagger\mathcal{B}_i^{\text{out}} \cup \dagger\mathcal{V}_{i-1}^-.$$

A similar argument shows the second assertion.  $\square$

By construction of the set  $\dagger\mathcal{V}_i^-$ , we have

$$\dagger\mathcal{U}_i^{\text{out}} \setminus \partial\dagger\mathcal{B}_i \subset \dagger\mathcal{V}_i^-,$$

and by (5.14)

$$\dagger\mathcal{U}_i^{\text{out}} \cap \dagger\mathcal{B}_i^{\text{side}} \subset \dagger\mathcal{V}_{i-1}^-.$$

It follows that the term

$$\bigcup_{i=1}^I W_{\dagger\mathbf{B}_i}^u(\dagger\mathcal{U}_i^{\text{out}}) \subset \dagger\mathbf{L}^{\text{slow}} \cup \bigcup_{i=1}^I W_{\dagger\mathbf{B}_i}^u(\dagger\mathcal{B}_i^{\text{out}}).$$

Comparing to (5.13) we see that after passing through the reassembly defined by  $\sim_2$  and  $\sim_3$ , the term  $\rho(\text{cl}(\dagger\mathbf{N}^-), \dagger\mathbf{N}, \varphi^0)$  becomes

$${}^\circ\mathbf{B}^- \cup \rho(\text{cl}(\cup_{y \in {}^\circ\mathbf{B}_i^{\text{in}}} {}^\circ\mathbf{U}_{i,y}^-), {}^\circ\mathbf{B}_i, \psi) \cup \rho(\text{cl}(\cup_{y \in {}^\circ\mathbf{B}_i^{\text{out}}} {}^\circ\mathbf{U}_{i,y}^-), {}^\circ\mathbf{B}_i, \psi)$$

and the term  $W_{\dagger\mathbf{B}_i}^u(\dagger\mathcal{U}_i^{\text{out}})$  becomes  $W_{{}^\circ\mathbf{B}_i}^u({}^\circ\mathcal{B}_i^{\text{out}})$  since the other part is a subset of  $\dagger\mathbf{L}_i^{\text{slow}}$ . Therefore,

$$\begin{aligned} \mathbf{L}_{{}^\circ\mathbf{B}_i}^{\text{fast}} &= {}^\circ\mathbf{B}_i^- \cup \rho(\text{cl}(\cup_{y \in {}^\circ\mathbf{B}_i^{\text{in}}} {}^\circ\mathbf{U}_{i,y}^-), {}^\circ\mathbf{B}_i, \psi) \\ &\quad \cup \rho(\text{cl}(\cup_{y \in {}^\circ\mathbf{B}_i^{\text{out}}} {}^\circ\mathbf{U}_{i,y}^-), {}^\circ\mathbf{B}_i, \psi) \cup W_{{}^\circ\mathbf{B}_i}^u({}^\circ\mathcal{B}_i^{\text{out}}). \end{aligned}$$

This finishes the verification of all assumptions for a local model.  $\square$

**Lemma 5.17** *Collection of sets  $({}^\circ\mathcal{U}_i^0, {}^\circ\mathcal{U}_i^1, {}^\circ\mathcal{V}_i^0, {}^\circ\mathcal{V}_i^1, {}^\circ\mathbf{U}_i^0, {}^\circ\mathbf{U}_i^1, {}^\circ\mathbf{B}_i, {}^\circ\mathbf{L}_i)$  and maps  $q_i$  for  $i = 1, \dots, I$  forms a collection of compatible local models.*



*Proof.* We only need to observe that

$$p_{1,i+1}^{-1}(\alpha'_{i+1}) = p_{0,i}^{-1}(\alpha_i) = \dagger U_i(\alpha_i)$$

$$\dagger V_{i+1}^1 \cap p_{1,i+1}^{-1}(1) = \dagger V_i^0 \cap p_{0,i}^{-1}(0) = \dagger V_i(\alpha_i).$$

□

Since all identifications used in definition of sets  $\mathcal{U}, \mathcal{V}, \mathcal{B}, \mathcal{U}, \mathcal{U}, \mathcal{V}, \mathcal{L}$  from the corresponding sets  $\mathcal{U}, \mathcal{V}, \mathcal{B}, \mathcal{U}, \mathcal{U}, \mathcal{V}, \mathcal{L}$  are done using homotopy equivalencies, we have a following corollary:

**Corollary 5.18** *For all  $i = 0, \dots, I$  and  $\lambda = \alpha_i$  or  $\lambda = \alpha'_i$*

$$H^*(\dagger \mathbf{N}_i(\lambda), \dagger \mathbf{L}_i(\lambda)) \cong H^*(\circ \mathbf{N}_i(\lambda), \circ \mathbf{L}_i(\lambda)) \quad (5.16)$$

and

$$H^*(\circ U_i(\lambda), \circ V_i(\lambda)) \cong H^*(\dagger U_i(\lambda), \dagger V_i(\lambda)). \quad (5.17)$$

Furthermore, for all  $y \in \mathcal{U}$

$$H^*(\circ \mathbf{U}_y, \circ \mathbf{V}_y) \cong H^*(\dagger \mathbf{U}_y, \dagger \mathbf{V}_y). \quad (5.18)$$

## 5.5 Proof of main theorems

### 5.5.1 Periodic corridor

#### Proof of Theorem 5.6

The statement (1) of the theorem was proven in Lemma 5.8. Now we prove the second part. Given a slow periodic corridor, by Subsection 5.4, there is a collection of compatible local models such that the singular index pair  $(\dagger \mathbf{N}, \dagger \mathbf{L})$  for the periodic corridor  $(\dagger \mathbf{N}, \dagger \mathbf{L})$  has the same cohomology as that of the index bundle  $(\circ \mathbf{N}, \circ \mathbf{L})$  constructed from the compatible local models. This last assertion is obvious from the Mayer-Vietoris sequence and the homotopy equivalence conditions in the definition of the corridor, see Definition 5.3. Therefore the statement (2) follows from Theorem 4.4. □

#### Proof of Theorem 1.7

The results follows immediately from Theorem 5.6 and and [14, Theorem 1.3], provided that the periodic corridor  $\dagger \mathbf{N}$  admits a Poincaré section. The proof of existence of a section is very similar to the proof presented in Section 6 of [9] and is therefore omitted. □

### 5.5.2 Heteroclinic corridor

Observe that the assumptions of the Theorem 5.7 are weaker than those of Theorem 5.6. We only assume that the map  $\Theta \neq 0$ . Since  $\Theta$  is not necessarily an isomorphism the pair  $(\dagger\mathbf{N}, \dagger\mathbf{L})$  may not (necessarily) be an index bundle and it does not (necessarily) admit a cohomological extension.

#### Proof of Theorem 5.7

The first statement of the theorem was proven in Lemma 5.9. Since the slow flow in each  $\dagger U_i$  flows from  $\dagger B'_i$  to  $\dagger B_i$ , and since each slow manifold  $M_i$  is normally hyperbolic and  $r$  is small, it follows that there is no connecting orbit connecting  $\text{Inv}(\dagger\mathbf{C}_A)$  to  $\text{Inv}(\dagger\mathbf{C}_R)$  inside  $\dagger\mathbf{N}$ . This proves the second statement of the theorem.

Now we prove the third statement. Let us consider the middle part of the heteroclinic corridor denoted by  $(\dagger\mathbf{N}^M, \dagger\mathbf{L}^M)$ , which is given by

$$\dagger\mathbf{N}^M = \bigcup_{i=0}^I \dagger\mathbf{N}_i, \quad \dagger\mathbf{L}^M = \dagger\mathbf{L} \cap \dagger\mathbf{N}^M,$$

and let  ${}^\circ\mathbf{N}^M, {}^\circ\mathbf{L}^M$  be corresponding ideal models of these sets. Recall that the set  $\dagger\mathbf{L} \cap \dagger\mathbf{C}_A$  is a union of the immediate exit set  $\dagger\mathbf{C}_A^-$  and the set  $\bigcup_{y \in \dagger C_A^L} \dagger\mathbf{N}_y$ . The set  $\dagger C_A^L$ , as well as the set  $\dagger C_R^L$ , have been defined in (5.10). Let  $\dagger\mathbf{N}_A := \dagger\mathbf{N}^M \cup \dagger\mathbf{C}_A$  and  $\dagger\mathbf{L}_A := \dagger\mathbf{L}^M \cup (\dagger\mathbf{L} \cap \dagger\mathbf{C}_A)$ . Notice, that the ideal models do not involve caps and thus we set

$${}^\circ\mathbf{C}_R := \dagger\mathbf{C}_R, \quad {}^\circ\mathbf{C}_A := \dagger\mathbf{C}_A.$$

We first prove a Lemma.

**Lemma 5.19** *We have the following isomorphisms:*

$$H^*(\dagger\mathbf{N}_I(\alpha_I), \dagger\mathbf{L}_I(\alpha_I)) \cong H^*(\dagger\mathbf{C}_R \cap \dagger\mathcal{U}, \dagger\mathbf{C}_R \cap \dagger\mathcal{V}) \otimes H^*(\dagger\mathbf{U}_y, \dagger\mathbf{U}_y^-); \quad (5.19)$$

$$CH^*(\text{Inv}(\dagger\mathbf{C}_R)) \cong CH^*(\text{Inv}(\dagger\mathbf{C}_R)) \otimes H^*(\dagger\mathbf{C}_{R,y}, \dagger\mathbf{C}_{R,y}^-). \quad (5.20)$$

$$H^*(\dagger\mathbf{N}_1(\alpha'_1), \dagger\mathbf{L}_1(\alpha'_1)) \cong CH^*(\text{Inv}(\dagger\mathbf{C}_A)) \otimes H^*(\dagger\mathbf{C}_{A,y}, \dagger\mathbf{C}_{A,y}^-); \quad (5.21)$$

$$CH^*(\text{Inv}(\dagger\mathbf{C}_A)) \cong CH^*(\text{Inv}(\dagger\mathbf{C}_A)) \otimes H^*(\dagger\mathbf{C}_{A,y}, \dagger\mathbf{C}_{A,y}^-). \quad (5.22)$$

*Proof.* The idea of the proof is similar to that of Theorem 3.14. We shall give the proof of first two isomorphisms. The other two isomorphisms can be proven exactly the same manner. From Theorem 3.14, we have

$$H^*({}^\circ\mathbf{N}_I(\alpha_I), {}^\circ\mathbf{L}_I(\alpha_I)) \cong H^*(\mathcal{U}_I(\alpha_I), \mathcal{V}_I(\alpha_I)) \otimes H^*({}^\circ\mathbf{N}_{I,\gamma}(\alpha_I), {}^\circ\mathbf{L}_{I,\gamma}(\alpha_I)).$$

By (5.17) we have

$$H^*(\mathcal{U}_I(\alpha_I), \mathcal{V}_I(\alpha_I)) = H^*(\dagger\mathcal{U}_I(\alpha_I), \dagger\mathcal{V}_I(\alpha_I))$$

and by construction of the heteroclinic corridor we have

$$H^*(\dagger\mathcal{U}_I(\alpha_I), \dagger\mathcal{V}_I(\alpha_I)) = H^*(\dagger\mathcal{C}_R \cap \dagger\mathcal{U}, \dagger\mathcal{C}_R \cap \dagger\mathcal{V}).$$

From the definition of the fast index bundle

$$H^*(\circ\mathbf{N}_{I,\gamma}(\alpha_I), \circ\mathbf{L}_{I,\gamma}(\alpha_I)) \cong H^*(\circ\mathbf{U}_y, \circ\mathbf{U}_y^-)$$

for some  $y$ . By (5.18)

$$H^*(\circ\mathbf{U}_y, \circ\mathbf{U}_y^-) = H^*(\dagger\mathbf{U}_y, \dagger\mathbf{U}_y^-)$$

and from (5.16)

$$H^*(\circ\mathbf{N}_I(\alpha_I), \circ\mathbf{L}_I(\alpha_I)) = H^*(\dagger\mathbf{N}_I(\alpha_I), \dagger\mathbf{L}_I(\alpha_I)).$$

The existence of the first isomorphism follows from these identifications.

The second isomorphism is obtained by

$$\begin{aligned} CH^*(\text{Inv}(\dagger\mathbf{C}_R)) &= H^*(\dagger\mathbf{C}_R, \dagger\mathbf{C}_R \cap \dagger\mathbf{L}) \\ &\cong H^*([-r, r]^k \times \dagger\mathbf{C}_R, \dagger\mathbf{C}_R^- \cup \bigcup_{y \in \dagger\mathbf{C}_R^L} \dagger\mathbf{N}_y) \\ &\cong H^*([-r, r]^k \times \dagger\mathbf{C}_R, \\ &\quad [-r, r]^s \times \partial[-r, r]^{k-s} \times \dagger\mathbf{C}_R \cup \bigcup_{y \in \dagger\mathbf{C}_R^L} \dagger\mathbf{C}_{R,y}) \\ &\cong H^*(\dagger\mathbf{C}_{R,y} \times \dagger\mathbf{C}_R, \dagger\mathbf{C}_{R,y}^- \times \dagger\mathbf{C}_R \cup \dagger\mathbf{C}_{R,y} \times \dagger\mathbf{C}_R^L) \\ &\cong H^*(\dagger\mathbf{C}_R, \dagger\mathbf{C}_R^L) \otimes H^*(\dagger\mathbf{C}_{R,y}, \dagger\mathbf{C}_{R,y}^-) \\ &\cong CH^*(\text{Inv}(\dagger\mathbf{C}_R)) \otimes H^*(\dagger\mathbf{C}_{R,y}, \dagger\mathbf{C}_{R,y}^-). \end{aligned}$$

□

The proof of the third statement of the Theorem 5.7 will follow from a series of Claims.

**Claim 1:**  $H^*(\dagger\mathbf{N}_A, \dagger\mathbf{L}_A) \cong H^*(\dagger\mathbf{N}^M, \dagger\mathbf{L}^M)$ .

*Proof.* Consider the Mayer-Vietoris sequence

$$\begin{aligned} \dots \rightarrow H^*(\dagger\mathbf{N}_A, \dagger\mathbf{L}_A) &\rightarrow H^*(\dagger\mathbf{C}_A, \dagger\mathbf{L} \cap \dagger\mathbf{C}_A) \oplus H^*(\dagger\mathbf{N}^M, \dagger\mathbf{L}^M) \\ &\rightarrow H^*(\dagger\mathbf{C}_A \cap \dagger\mathbf{N}^M, \dagger\mathbf{L} \cap \dagger\mathbf{C}_A \cap \dagger\mathbf{L}^M) \rightarrow \dots \end{aligned}$$

Since  $(\dagger\mathbf{C}_A \cap \dagger\mathbf{N}^M, \dagger\mathbf{L} \cap \dagger\mathbf{C}_A \cap \dagger\mathbf{L}^M) = (\dagger\mathbf{N}_1(\alpha'), \dagger\mathbf{L}_1(\alpha'))$  and  $CH^*(\text{Inv}(\dagger\mathbf{C}_A)) = H^*(\dagger\mathbf{C}_A, \dagger\mathbf{L} \cap \dagger\mathbf{C}_A)$  by definition, we have

$$H^*(\dagger\mathbf{C}_A, \dagger\mathbf{L} \cap \dagger\mathbf{C}_A) \cong H^*(\dagger\mathbf{C}_A \cap \dagger\mathbf{N}^M, \dagger\mathbf{L} \cap \dagger\mathbf{C}_A \cap \dagger\mathbf{L}^M)$$

from (5.21) and (5.22). Thus the claim follows from the above exact sequence.  $\square$

**Claim 2:** The following sequence is exact:

$$\rightarrow H^*(\dagger\mathbf{N}, \dagger\mathbf{L}) \rightarrow H^*(\dagger\mathbf{N}^M, \dagger\mathbf{L}^M) \xrightarrow{\dagger\mathbf{X}} H^*(\dagger\mathbf{N}_I(\alpha_I), \dagger\mathbf{L}_I(\alpha_I)) \rightarrow$$

*Proof.* Consider the Mayer-Vietoris sequence

$$\begin{aligned} \dots \rightarrow H^*(\dagger\mathbf{N}, \dagger\mathbf{L}) &\rightarrow H^*(\dagger\mathbf{C}_R, \dagger\mathbf{C}_R^- \cup \bigcup_{y \in \dagger C_R^L} \dagger\mathbf{N}_y) \oplus H^*(\dagger\mathbf{N}_A, \dagger\mathbf{L}_A) \\ &\rightarrow H^*(\dagger\mathbf{C}_R \cap \dagger\mathbf{N}_A, (\dagger\mathbf{C}_R^- \cup \bigcup_{y \in \dagger C_R^L} \dagger\mathbf{N}_y) \cap \dagger\mathbf{L}_A) \rightarrow \dots \end{aligned}$$

From (5.20) of Lemma 5.19, we have

$$\begin{aligned} H^*(\dagger\mathbf{C}_R, \dagger\mathbf{C}_R^- \cup \bigcup_{y \in \dagger C_R^L} \dagger\mathbf{N}_y) &= CH^*(\text{Inv}(\dagger\mathbf{C}_R)) \\ &\cong CH^*(\text{Inv}(\dagger C_R)) \otimes H^*(\dagger\mathbf{C}_{R,y}, \dagger\mathbf{C}_{R,y}^-) \\ &= H^*(\dagger C_R, \dagger C_R^L) \otimes H^*(\dagger\mathbf{C}_{R,y}, \dagger\mathbf{C}_{R,y}^-). \end{aligned}$$

By definition

$$H^*(\dagger\mathbf{C}_R \cap \dagger\mathbf{N}_A, (\dagger\mathbf{C}_R^- \cup \bigcup_{y \in \dagger C_R^L} \dagger\mathbf{N}_y) \cap \dagger\mathbf{L}_A) = H^*(\dagger\mathbf{N}_I(\alpha_I), \dagger\mathbf{L}_I(\alpha_I)),$$

and therefore the claim follows if  $H^*(\dagger C_R, \dagger C_R^L) = 0$ . Indeed, since by (5.10)  $\dagger C_R^L = \dagger C_R^- \setminus \dagger U_I$ , we have another Mayer-Vietoris sequence,

$$\begin{aligned} \dots \rightarrow H^*(\dagger C_R, \dagger C_R^-) &\rightarrow H^*(\dagger C_R, \dagger C_R^L) \oplus H^*(\dagger U_I(\alpha_I), \dagger U_I(\alpha_I)) \\ &\rightarrow H^*(\dagger U_I(\alpha_I), \dagger V_I(\alpha_I)) \rightarrow H^{*+1}(\dagger C_R, \dagger C_R^-) \dots \end{aligned}$$

Noticing that  $H^{*+1}(\dagger C_R, \dagger C_R^-) = CH^{*+1}(\text{Inv}(\dagger C_R)) \cong H^*(\dagger C_R \cap \dagger U_I, \dagger C_R \cap \dagger V_I) \cong H^*(\dagger U_I(\alpha_I), \dagger V_I(\alpha_I))$  from the assumption of Theorem 5.7, we obtain

$$H^*(\dagger C_R, \dagger C_R^L) \oplus H^*(\dagger U_I(\alpha_I), \dagger U_I(\alpha_I)) = H^*(\dagger C_R, \dagger C_R^L) = 0.$$

$\square$

As a consequence of Claim 2 and the ideal model identification, there is a commutative diagram

$$\begin{array}{ccccccc} \rightarrow & H^*(\dagger\mathbf{N}, \dagger\mathbf{L}) & \rightarrow & H^*(\dagger\mathbf{N}^M, \dagger\mathbf{L}^M) & \xrightarrow{\dagger\mathbf{X}} & H^*(\dagger\mathbf{N}_I(\alpha), \dagger\mathbf{L}_I(\alpha)) & \rightarrow \\ & \downarrow & & \downarrow & & \downarrow & \\ \rightarrow & H^*(\circ\mathbf{N}, \circ\mathbf{L}) & \rightarrow & H^*(\circ\mathbf{N}^M, \circ\mathbf{L}^M) & \xrightarrow{\circ\mathbf{X}} & H^*(\circ\mathbf{N}_I(\alpha), \circ\mathbf{L}_I(\alpha)) & \rightarrow \end{array} \quad (5.23)$$

where vertical maps are isomorphisms induced by model identification and vertical lines are exact.

**Claim 3:** The maps  $\dagger\mathbf{X}$  and  ${}^\circ\mathbf{X}$  above are not zero maps.

*Proof.* Since the digram commutes and vertical maps are isomorphisms, it is enough to prove that  ${}^\circ\mathbf{X}$  is non-zero. Observe that this map is nothing but the map  $i^*$  in the Key diagram (Theorem 3.17). Therefore the conclusion follows if we show that the right vertical line of the Key diagram is non-zero.

We identify the map  ${}^\circ\mathbf{X}$  in more detail using the Key diagram for the pair  $({}^\circ\mathbf{N}, {}^\circ\mathbf{L})$ . Take a generator  $\eta \in H^*({}^\circ\mathbf{N}^{\text{fib}}, {}^\circ\mathbf{L}^{\text{fib,fast}})$  such that  $\eta' = i^* \circ e_f(\eta) \neq 0$  in  $H^*({}^\circ\mathbf{N}(\alpha'), {}^\circ\mathbf{L}^{\text{fast}}(\alpha'))$ . This is possible, since  $i^* \circ e_f = \Theta$ , which by assumption is not a zero map. We can also choose a non-trivial  $\delta \in H^*({}^\circ\mathbf{N}^{\text{fib}}, {}^\circ\mathbf{L}^{\text{fib,slow}})$  and we have  $\delta' = i^* \circ e_s(\delta) \neq 0$  in  $H^*({}^\circ\mathbf{N}(\alpha'), {}^\circ\mathbf{L}^{\text{slow}}(\alpha'))$ , since  $e_s$  is a cohomological extension of the index bundle  $({}^\circ\mathbf{N}, {}^\circ\mathbf{L})$ .

Since, by the commutativity of the Key diagram,  $\delta' \smile \eta' = (i^* \circ \overline{e_s \otimes e_f})(\delta \smile \eta)$ ,  ${}^\circ\mathbf{X} = i^*$  is not a zero map if  $\delta' \smile \eta' \neq 0$ . Since the cup product is an isomorphism if it is restricted to the fiber, it is equivalent to  $\delta' \otimes \eta' \neq 0$  which is obvious from the definition of the tensor product and  $\delta' \neq 0, \eta' \neq 0$ .  $\square$

**Claim 4:**  $H^*(\dagger\mathbf{N}, \dagger\mathbf{L}) \cong H^*(\dagger\mathbf{N}^M, \dagger\mathbf{L}^M) \oplus H^*(\dagger\mathbf{N}_I(\alpha_I), \dagger\mathbf{L}_I(\alpha_I))$ .

*Proof.* This is a direct consequence of Claim 3 and Lemma 5.2 in [9].  $\square$

In the last two Claims we identify the homology groups on the right hand side of Claim 4.

**Claim 5:**  $H^*(\dagger\mathbf{N}_I(\alpha_I), \dagger\mathbf{L}_I(\alpha_I)) \cong CH^{*+1}(\text{Inv}(\dagger\mathbf{C}_R))$ .

*Proof.* From (5.19), we have

$$H^*({}^\circ\mathbf{N}_I(\alpha_I), {}^\circ\mathbf{L}_I(\alpha_I)) \cong H^{*-s}({}^\circ\mathcal{C}_R \cap {}^\circ\mathcal{U}, {}^\circ\mathcal{C}_R \cap {}^\circ\mathcal{V}) \otimes H^s({}^\circ\mathbf{U}_y, {}^\circ\mathbf{U}_y^-). \quad (5.24)$$

By definition we also have

$$H^{*-s}({}^\circ\mathcal{C}_R \cap {}^\circ\mathcal{U}, {}^\circ\mathcal{C}_R \cap {}^\circ\mathcal{V}) \cong H^{*-s}({}^\circ\mathcal{C}_R \cap {}^\circ\mathcal{U}, {}^\circ\mathcal{C}_R \cap {}^\circ\mathcal{V}),$$

and, by construction,

$$H^{*-s}({}^\circ\mathcal{C}_R \cap {}^\circ\mathcal{U}, {}^\circ\mathcal{C}_R \cap {}^\circ\mathcal{V}) = H^{*-s}({}^\circ U_I(\alpha_I), {}^\circ V_I(\alpha_I)).$$

Since by (5.17) of Corollary 5.18

$$H^{*-s}({}^\circ U_I(\alpha_I), {}^\circ V_I(\alpha_I)) \cong H^{*-s}(\dagger U_I(\alpha_I), \dagger V_I(\alpha_I))$$

we can use the (5.8) to compute the latter as

$$H^{*-s}(\dagger U_I(\alpha_I), \dagger V_I(\alpha_I)) \cong CH^{*-s+1}(\text{Inv}(\dagger\mathbf{C}_R)).$$

Therefore at this point of calculation equation (5.24) reads

$$H^*(\circ\mathbf{N}_I(\alpha_I), \circ\mathbf{L}_I(\alpha_I)) \cong CH^{*-s+1}(\text{Inv}(\dagger C_R)) \otimes H^s(\circ\mathbf{U}_y, \circ\mathbf{U}_y^-). \quad (5.25)$$

Since

$$CH^{*-s+1}(\text{Inv}(\circ C_R)) = CH^{*-s+1}(\text{Inv}(\dagger C_R))$$

and  $H^s(\circ\mathbf{U}_y, \circ\mathbf{U}_y^-) \cong H^s(\circ\mathbf{C}_{R,y}, \circ\mathbf{C}_{R,y}^-)$ , it follows from (5.20) that

$$\begin{aligned} CH^{*-s+1}(\text{Inv}(\circ C_R)) \otimes H^s(\circ\mathbf{U}_y, \circ\mathbf{U}_y^-) &\cong CH^{*+1}(\text{Inv}(\circ\mathbf{C}_R)) \\ &\cong CH^{*+1}(\text{Inv}(\dagger\mathbf{C}_R)) \end{aligned}$$

for some  $y \in \circ C_R$ . Therefore from (5.25) and (5.16) of Corollary 5.18 we get

$$\begin{aligned} H^*(\dagger\mathbf{N}_I(\alpha_I), \dagger\mathbf{L}_I(\alpha_I)) &\cong H^*(\circ\mathbf{N}_I(\alpha_I), \circ\mathbf{L}_I(\alpha_I)) \\ &\cong CH^{*-s+1}(\text{Inv}(\circ C_R)) \otimes H^s(\circ\mathbf{U}_y, \circ\mathbf{U}_y^-) \\ &\cong CH^{*+1}(\text{Inv}(\dagger\mathbf{C}_R)). \end{aligned}$$

Note that here we have used  $CH^0(\text{Inv}(\dagger C_R)) = 0$  in order to obtain the last isomorphism, which follows from the fact that the repelling cap  $\dagger C_R$  is homeomorphic to a disc and has non-empty exit set.  $\square$

**Claim 6:**  $H^*(\dagger\mathbf{N}^M, \dagger\mathbf{L}^M) \cong CH^*(\text{Inv}(\dagger\mathbf{C}_A))$ .

*Proof.* It follows from Proposition 5.13 that

$$H^*(\dagger\mathbf{N}^M, \dagger\mathbf{L}^M) \cong H^*(\circ\mathbf{N}^M, \circ\mathbf{L}^M).$$

We note that from Corollary 4.7,

$$H^*(\circ\mathbf{N}^{\text{fib}}, \circ\mathbf{L}^{\text{fib}}) \cong H^*(\circ\mathbf{N}^M, \circ\mathbf{L}^M).$$

Also by (3.7),

$$H^*(\circ\mathbf{N}^{\text{fib}}, \circ\mathbf{L}^{\text{fib}}) \cong H^{*-s}(\circ U_1(\alpha'_1), \circ V_1(\alpha'_1)) \otimes H^s(\circ\mathbf{U}_y, \circ\mathbf{U}_y^-),$$

for some  $y \in \mathcal{U}_i(\alpha'_1)$ . By (5.18)

$$H^{*-s}(\circ U_1(\alpha'_1), \circ V_1(\alpha'_1)) \cong H^{*-s}(\dagger U_1(\alpha'_1), \dagger V_1(\alpha'_1)).$$

Since by (5.8) we have

$$H^{*-s}(\dagger U_1(\alpha'_1), \dagger V_1(\alpha'_1)) \cong CH^{*-s}(\text{Inv}(\dagger C_A)),$$

it follows

$$\begin{aligned} H^*(\dagger\mathbf{N}^M, \dagger\mathbf{L}^M) &\cong H^*(\circ\mathbf{N}^M, \circ\mathbf{L}^M) \cong H^*(\circ\mathbf{N}^{\text{fib}}, \circ\mathbf{L}^{\text{fib}}) \\ &\cong H^{*-s}(\circ U_1(\alpha'_1), \circ V_1(\alpha'_1)) \otimes H^s(\circ\mathbf{U}_y, \circ\mathbf{U}_y^-) \\ &\cong CH^{*-s}(\text{Inv}(\dagger C_A)) \otimes H^s(\dagger\mathbf{U}_y, \dagger\mathbf{U}_y^-). \end{aligned}$$

By definition of  $\dagger\mathbf{C}_A$  the last product is

$$CH^{*-s}(\text{Inv}(\dagger\mathbf{C}_A) \otimes H^s(\dagger\mathbf{U}_y, \dagger\mathbf{U}_y^-) \cong CH^*(\text{Inv}(\dagger\mathbf{C}_A))$$

from which we obtain the conclusion.  $\square$

Since  $\dagger\mathbf{X} \neq 0$  by Claim 3, it follows from Claims 4, 5, 6 that  $H^*(\dagger\mathbf{N}, \dagger\mathbf{L})$  is not isomorphic to a direct sum of  $CH^*(\text{Inv}(\dagger\mathbf{C}_A))$  and  $CH^*(\text{Inv}(\dagger\mathbf{C}_R))$ . This finishes the proof of Theorem 5.7.  $\square$

### Proof of Theorem 1.9

By Theorem 5.7.2  $(\text{Inv}(\dagger\mathbf{C}_R), \text{Inv}(\dagger\mathbf{C}_A))$  is an attractor-repeller decomposition for  $\text{Inv}(\dagger\mathbf{N}, \varphi^\epsilon)$  and by Theorem 5.7.3

$$CH^*(\text{Inv}(\dagger\mathbf{C}_R, \varphi^\epsilon)) \oplus CH^*(\text{Inv}(\dagger\mathbf{C}_A, \varphi^\epsilon)) \not\cong CH^*(\text{Inv}(\dagger\mathbf{N}, \varphi^\epsilon)).$$

Therefore, by [1, Theorem 3.3.1], there exists a heteroclinic orbit connecting  $\text{Inv}(\dagger\mathbf{C}_R)$  to  $\text{Inv}(\dagger\mathbf{C}_A)$  in  $\dagger\mathbf{N}$  for all sufficiently small  $\epsilon$ .  $\square$

## A Appendix: Conley index theory

This section contains a brief review of relevant portions of the Conley index theory. For the general theory the reader is referred to [1, 3, 19] and references therein. Throughout this section we shall let  $\varphi : \mathbb{R} \times \mathbb{R}^n \rightarrow \mathbb{R}^n$  denote a flow on  $\mathbb{R}^n$ .

To simplify the notation we let  $z = (x, y) \in \mathbb{R}^n = \mathbb{R}^k \times \mathbb{R}^l$  and write

$$\dot{z} = F(z) = F_0(z) + \epsilon F_1(z) + \dots + \epsilon^k F_k(z) + \dots \quad (\text{A.1})$$

in place of equation (1.1). As will be seen, it is not necessary that  $F$  be analytic or  $C^\infty$  in  $\epsilon$ , only that  $F$  have enough derivatives to apply Theorem A.6 below.

**Definition A.1** A compact set  $N \subset \mathbb{R}^n$  is called a *singular isolating neighborhood* if  $N$  is not an isolating neighborhood for  $\varphi^0$ , but there is an  $\bar{\epsilon} > 0$  such that for all  $\epsilon \in (0, \bar{\epsilon}]$ ,  $N$  is an isolating neighborhood for  $\varphi^\epsilon$ .

**Definition A.2** A pair of compact sets  $(N, L)$  with  $N \subset L$  is a *singular index pair* if  $\text{cl}(N \setminus L)$  is a singular isolating neighborhood and there is an  $\bar{\epsilon} > 0$  such that for all  $\epsilon \in (0, \bar{\epsilon}]$

$$H^*(N, L) \cong CH^*(\text{Inv}(\text{cl}(N \setminus L), \varphi^\epsilon)).$$

Observe that the last two definitions are most useful if we find a way to construct singular isolating neighborhoods and singular index pairs using primarily the  $\varphi^0$  flow, along with minimal information about the higher order terms of  $F$ . The conditions for the existence of a singular isolating neighborhood were given

by Conley [4] and the construction of a singular index pair was done in [16]. We shall follow the latter paper in our exposition.

Let  $N$  be a compact set and let  $S = \text{Inv}(N, \varphi^0)$ . Observe that if  $N$  is not an isolating neighborhood for  $\varphi^0$ , then by definition there exists  $z \in S \cap \partial N$ . If  $N$  is to be a singular isolating neighborhood, then such an  $z$  has to leave in forward or backward time under  $\varphi^\epsilon$  for all  $\epsilon > 0$ . This leads to the following definition.

**Definition A.3** Let  $N$  be a compact set and let  $z \in S$ .  $z$  is a *slow exit* [resp. *entrance*] *point* if there exists a neighborhood  $U$  of  $z$  and an  $\bar{\epsilon} > 0$  such that for all  $\epsilon \in (0, \bar{\epsilon}]$  there exists a time  $T(\epsilon, U) > 0$  [resp.  $T(\epsilon, U) < 0$ ] satisfying

$$\varphi^\epsilon(T(\epsilon, U), U) \cap N = \emptyset.$$

**Theorem A.4 ([16] Theorem 1.5)** *Let  $N$  be a compact set. If  $S \cap \partial N$  consists of slow entrance and slow exit points, then  $N$  is a singular isolating neighborhood.*

It follows from the last theorem that, in order to construct a singular isolating neighborhood, it is important to be able to recognize slow exit and slow entrance points. Before we quote a theorem which does just that, we introduce some notation. We let  $S^-$  [resp.  $S^+$ ] denote the set of slow exit [resp. entrance] points. Set  $S_\partial := S \cap \partial N$  and  $S_\partial^\pm := S_\partial \cap S^\pm$ . Given an invariant set  $K$ , let  $\mathfrak{R}(K)$  denote the chain recurrent set of  $K$  under  $\varphi^0$ .

**Definition A.5** The average of  $h$  on  $S$ ,  $\text{Ave}(h, S)$  is the limit as  $t \rightarrow \infty$  of the set of numbers  $\{\frac{1}{t} \int_0^t h(\varphi^0(s, x)) ds \mid x \in S\}$ . If  $\text{Ave}(h, S) \subset (0, \infty)$ , then  $h$  has *strictly positive averages* on  $S$ .

**Theorem A.6 ([4])**  *$w \in S$  is a slow exit point if there exists a compact set  $K_w \subset S$  invariant under  $\varphi^0$ , a neighborhood  $U_w$  of  $\mathfrak{R}(K_w)$ , an  $\bar{\epsilon} > 0$  and a function  $l : \text{cl}(U_w) \times [0, \bar{\epsilon}] \rightarrow \mathbb{R}$  such that the following conditions are satisfied.*

(1)  $\omega(w, \varphi^0) \subset K_w$ ;

(2)  $l$  is of the form

$$l(z, \epsilon) = l_0(z) + \epsilon l_1(z) + \dots + \epsilon^m l_m(z);$$

(3) If  $L_0 = \{z \mid l_0(z) = 0\}$ , then

$$K_w \cap \text{cl}(U_w) = S \cap L_0 \cap \text{cl}(U_w),$$

and furthermore  $l_0|_{S \cap \text{cl}(U_w)} \leq 0$ ;

(4) Let

$$h_j(z) = \nabla_z l_0(z) \cdot F_j(z) + \nabla_z l_1(z) \cdot F_{j-1}(z) + \dots + \nabla_z l_j(z) \cdot F_0(z).$$

Then for some  $m$ ,  $h_j \equiv 0$  if  $j < m$ , and  $h_m$  has strictly positive averages on  $\mathfrak{R}(K_w)$ .



A slow exit point which satisfies the conditions of Theorem A.6 is called a *C-slow exit point*. If we reverse time we can use the Theorem A.6 to test for slow entrance points. Slow entrance points of this form will be called *C-slow entrance points*.

Now, given a singular isolating neighborhood  $N$ , we want to identify a singular index pair. We need a few definitions. The *immediate exit set* for  $N$  is defined by

$$N^- := \{z \in \partial N \mid \varphi^0((0, t), z) \not\subset N \text{ for all } t > 0\}.$$

Given  $Y \subset N$  its *push forward set* in  $N$  under the flow  $\varphi^0$  is defined to be

$$\rho(Y, N, \varphi^0) := \{z \in N \mid \exists w \in Y, t \geq 0 \text{ such that } \varphi^0([0, t], w) \subset N, \varphi^0(t, w) = z\}.$$

Finally, the *unstable set* of an invariant set  $Y \subset N$  under  $\varphi^0$  is

$$W_N^u(Y) := \{z \in N \mid \varphi^0((-\infty, 0), z) \subset N \text{ and } \alpha_{\varphi^0}(z) \subset Y\}.$$

A slow entrance point  $z$  is a *strict slow entrance point* if there exists a neighborhood  $\Theta_z$  of  $z$  and an  $\bar{\epsilon} > 0$  such that if  $w \in \Theta_z \cap N$  and  $\epsilon \in (0, \bar{\epsilon}]$ , then there exists  $t_w(\epsilon) > 0$  for which

$$\varphi^\epsilon([0, t_w(\epsilon)], w) \subset N.$$

We will let  $S_\partial^{++}$  denote the strict slow entrance points.

**Theorem A.7 ([16] Theorem 1.16)** *Let  $N$  be a singular isolating neighborhood. Assume*

- (1)  $S_\partial^-$  consists of *C-slow exit points*.
- (2)  $S_\partial \subset S_\partial^{++} \cup S_\partial^-$ .
- (3)  $(S_\partial^{++} \setminus S_\partial^-) \cap \text{cl}(N^-) = \emptyset$

For each  $z \in S_\partial^-$ , let  $K_z$  denote a compact invariant set as in Theorem A.6. Define

$$L := \rho(\text{cl}(N^-), N, \varphi^0) \cup W_N^u\left(\bigcup_{z \in S_\partial^-} \mathfrak{R}(K_z)\right).$$

If  $L$  is closed, then  $(N, L)$  is a singular index pair for the family of flows  $\varphi^\epsilon$ .

## B Appendix: Singular index pairs

### B.1 Proof of Lemma 5.8

We first define a convenient set of coordinates on any slow sheet  $E_i \subset M$ , where  $M$  is a normally hyperbolic slow manifold. We choose new variables  $(\xi, \eta)$  such that

$$M := \{(\xi, \eta) \in \mathbb{R}^k \times \mathbb{R}^\ell \mid \xi = 0\},$$

and the flow on the flow box  $E_i$  is given by

$$\dot{\xi} = 0, \quad \dot{\eta}_1 = 1, \quad \dot{\eta}_i = 0, \quad i = 2, \dots, \ell. \quad (\text{B.1})$$

By rescaling the time interval  $[\sigma_i^{\text{in}}(z), \tau_i^{\text{out}}(z)]$  to the interval  $[0, 1]$  for all  $z$  and all  $i$ , we can, in the new coordinates, write

$$\dagger U_i = \{0\} \times [0, 1] \times [0, b]^{\ell-1}.$$

Our proof consists of three parts.

- (1) First we show that the set

$$\bigcup_{i=0}^I \dagger V_i^- \cup \bigcup_{i=1}^I \bigcup_{y \in \dagger \mathcal{Q}_i \cap \dagger \mathcal{V}_{i-1}^-} C_{i,y} \quad (\text{B.2})$$

consists of C-slow exit points.

- (2) The second step is to show that

$$\bigcup_{i=0}^I (\dagger U_i^{\text{side}} \setminus \dagger V_i^-) \cup \bigcup_{i=1}^I \bigcup_{y \in \dagger \mathcal{Q}_i \setminus \dagger \mathcal{V}_{i-1}^-} C_{i,y} \quad (\text{B.3})$$

consists of C-slow entrance points

- (3) As a last step we show that  $\bigcup_{i=1}^I \dagger U_i^{\text{in}}$  consists of C-slow entrance points and  $\bigcup_{i=1}^I \dagger U_i^{\text{out}}$  consists of C-slow exit points.

**Step 1:** Let  $C_i := \bigcup_{w \in \dagger \mathcal{Q}_i \cap \dagger \mathcal{V}_{i-1}^-} C_{i,w}$ . We use notation of Theorem A.6 in the next computation. For every  $z \in C_i \cup \dagger V_{i-1}^-$ , we take  $K_z^i := \dagger V_{i-1}^-$  and then  $\mathfrak{K}(K_z^i) = \dagger V_{i-1}^-$ . It follows by definition that the omega limit set  $\omega(z) \subset \dagger V_{i-1}^-$  for any  $z \in C_i \cup \dagger V_{i-1}^-$ .

Fix  $i \in \{1, \dots, I\}$  and choose a neighborhood  $U$  of  $K_z^i = \dagger V_{i-1}^-$ . We construct  $l = l_0 + \epsilon l_1$  as follows: Let

$$l_0(\xi, \eta) = p(\eta_2, \dots, \eta_\ell) - (\xi_1^2 + \xi_2^2 + \dots + \xi_k^2),$$

where the smooth function  $p$  satisfies  $p(\eta_2, \dots, \eta_\ell) \equiv 0$  for all  $(\xi, \eta)$  with  $\eta \in \dagger V_{i-1}^-$  and  $p(\eta)$  is negative elsewhere.

Since  $\dagger V_{i-1}^-$  is invariant under the flow  $\varphi_{i-1}^{\text{slow}}$ , which in the rescaled version is flow  $\dot{\eta}_1 = 1$ , it is possible to choose function  $p$  as a function of variables  $\eta_2, \dots, \eta_\ell$  only.

Define function  $l_1$  by

$$l_1 = \eta_1.$$

We now identify the set  $L_0 := \{u \mid l_0(u) = 0\}$ . Observe that  $u = (\xi, \eta) \in L_0$  if and only if  $p(\eta) = 0$  and  $\xi = 0$ .

By our choice of the function  $p$ , conditions  $p(\eta) = 0$  and  $\xi = 0$  are satisfied, if and only if that  $u \in \dagger V_{i-1}^-$ . Since  $K_z^i = \dagger V_{i-1}^-$ , this shows that

$$K_z^i \cap \text{cl}(U) = S \cap L_0 \cap \text{cl}(U).$$

This, together with the fact that  $l_0$  is negative on  $C_i \subset S$ , implies that

$$l_0|_{S \cap \text{cl}(U)} \leq 0.$$

This verifies assumptions 1-3 of Theorem A.6 for  $z \in C_i \cup \dagger V_{i-1}^-$  with  $K_z = \mathfrak{R}(K_z) = \dagger V_{i-1}^-$ . Recall that  $F = F_0 + \epsilon F_1 = (f, 0) + \epsilon(0, g)$ . Now we compute the averages, where we evaluate these averages on  $\dagger V_{i-1}^-$ . Observe that if  $u = (\xi, \eta) \in \mathfrak{R}(K_z) = \dagger V_{i-1}^-$ , then  $\xi = 0$ . It follows from the construction of  $l_0$  that  $\nabla l_0|_{\mathfrak{R}(K_z)}$  may have nonzero components only in directions  $w_2, \dots, w_l$ . Since  $F_0$  has nonzero components only in  $\xi$ -directions, we have  $h_0 := \nabla l_0 \cdot F_0 = 0$ .

Since  $\nabla l_1$  has a nonzero component only in the  $w_1$  direction,  $\nabla l_1 \cdot F_0 = 0$ . In our new coordinates  $(z, w)$  the function  $F_1$  has nonzero component only in the  $w_1$  direction. Therefore,  $\nabla l_0 \cdot F_1 = 0$  and thus

$$h_1 := \nabla l_1 \cdot F_0 + \nabla l_0 \cdot F_1 = 0.$$

Finally,

$$h_2 = \nabla l_2 \cdot F_0 + \nabla l_1 \cdot F_1 + \nabla l_0 \cdot F_2 = \nabla l_1 \cdot F_1 = 1 > 0.$$

This finishes the proof of (B.2).

**Step 2:** By assumption (5.4), we have that  $\dagger U_i^{\text{side}} \subset \text{int}_{\dagger U_i} \dagger V_i^+ \cup \text{int}_{\dagger U_i} \dagger V_i^-$ . It follows that  $(\dagger U_i^{\text{side}} \setminus \dagger V_i^-) \subset \dagger V_i^+$ . Similarly,  $\dagger Q_i \setminus \dagger \mathcal{V}_{i-1}^- \subset \dagger Q_i \cap \dagger \mathcal{V}_i^+$ . Therefore, the left hand side of (B.3) is analogous to the left hand side of (B.2), where  $\dagger V_i^+$  plays the role of the set  $\dagger V_{i-1}^-$ . If we reverse the flow  $\varphi_i^{\text{slow}}(x, t)$  then the analogy is complete, since the entrance set becomes the exit set under the reversed flow.

So using the function  $l = l_0 + \epsilon l_1$  from Step 1, where  $p = 0$  on  $\dagger V_i^+$  and the function  $k(\xi_1)$  is chosen in the same way, and working with the reverse of the flow  $\varphi_i^{\text{slow}}(z, t)$ , we get the analogous result.

**Step 3:** Observe that  $\dagger U_i^{\text{in}}$  is a strict entrance set under the slow flow  $\varphi_i^{\text{slow}}$  and the set  $\dagger U_i^{\text{out}}$  is a strict exit set under  $\varphi_i^{\text{slow}}$ . These situations are equivalent under reversion of the flow  $\varphi_i^{\text{slow}}$ . We will show that the fact that  $\dagger U_i^{\text{out}}$  is a strict exit set under  $\varphi_i^{\text{slow}}$  implies that  $\dagger U_i^{\text{out}}$  is in C-slow exit set for each  $i$ . By an analogous argument with reversed slow flow the set  $\dagger U_i^{\text{in}}$  is in C-slow entrance set for each  $i$ .

We will prove the result for the set  $\dagger U_i^{\text{out}}$  by choosing an arbitrary point  $z \in \dagger U_i^{\text{out}}$  and showing that it is a C-slow exit point. Observe that the flow  $\varphi_i^{\text{slow}}$  is transversal to  $\dagger U_i^{\text{out}}$  by definition of  $\dagger U_i^{\text{out}}$  and continuity of the functions  $\tau_i^{\text{in}}$  and  $\tau_i^{\text{out}}$  (assumption **(H4)**). Let  $v(z)$  be the  $\varphi_i^{\text{slow}}$  direction at  $z$ . Obviously,

$v(z)$  lies in the tangent space of the slow manifold  $M$ . For this  $z \in \dagger U_i^{\text{out}}$ , take  $K_z = \mathfrak{K}(K_z) = \dagger U_i^{\text{out}}$ . Let  $l = l_0$  be a continuous function, defined in the neighborhood  $U$  of  $\dagger U_i^{\text{out}}$ , strictly increasing in the direction  $v(z)$  at  $y \in \dagger U_i^{\text{out}}$ , with  $l(y) \leq 0$  for  $y \in \dagger U_i \cap U$  and  $l(\dagger U_i^{\text{out}}) = 0$ . Since  $K_z = \dagger U_i^{\text{out}}$  this implies

$$K_z \cap \text{cl}(U) = \dagger U_i^{\text{out}} \cap L_0 \cap \text{cl}(U).$$

Computing the averages, we get  $\nabla l_0 \cdot F_0 = 0$ , since  $\nabla l_0$  lies in the tangent space of the manifold  $M$ , which is level set of  $F_0$ . The next average

$$\nabla l_0 \cdot F_1 + \nabla l_1 \cdot F_0 = \nabla l_0 \cdot F_1 = 1,$$

since  $F_1$  represents the slow flow transverse to  $\dagger U_i^{\text{out}}$  and  $l_1 \equiv 0$ . Since  $z \in \dagger U_i^{\text{out}}$  was arbitrary,  $\dagger U_i^{\text{out}}$  consists of C-slow exit points.  $\square$

**Remark B.1** Observe that transversality of the slow flow  $\varphi_i^{\text{slow}}$  to  $\dagger U_i^{\text{in}}$  shows that  $\bigcup_{i=1}^I \dagger U_i^{\text{in}}$  consists of strict entrance points.

## B.2 Proof of Lemma 5.9

The only difference between a heteroclinic corridor and a periodic corridor are the caps. However, the boundary of the cap consists of sections of the slow flow since caps are isolating blocks. The set  $\dagger C_R^L \cap \partial \dagger \mathbf{N}$  is a slow immediate exit set as is every set  $\dagger U_i^{\text{out}}$  and the set  $\dagger C_R^E \cap \partial \dagger \mathbf{N}$  is a slow immediate entrance set as is the set  $\dagger U_i^{\text{in}}$ . Thus, the analogous construction of  $h$ , as in the previous lemma for  $\dagger U_i^{\text{out}}$ , works for  $\dagger C_R^L \cap \partial \dagger \mathbf{N}$  and shows that  $\dagger C_R^L \cap \partial \dagger \mathbf{N}$  consists of C-slow exit points. A similar argument for the reverse flow shows that  $\dagger C_R^E \cap \partial \dagger \mathbf{N}$  consists of C-slow entrance points. Obviously, this also applies to the attracting cap  $\dagger C_A$ .

## B.3 Singular index pair

The goal of this section is to prove Propositions 5.12 and 5.13. We shall prove only Proposition 5.12 since the proof of Proposition 5.13 is analogous.

Our basic tool is Theorem A.7, which prescribes how to build a singular index pair out of singular isolating neighborhood. However, there are two reasons why this theorem is not directly applicable. One is that the assumption (2) of Theorem A.7 is not satisfied, since we have only shown that  $S_\partial \subset \mathbf{S}^- \cup \mathbf{S}^+$  and consists of C-slow exit and entrance points. To verify this assumption we would have to show that all points in  $\mathbf{S}^+$  are actually strict entrance points. However, since  $\dagger U_i$  is a flow box, the set  $\dagger U_i^{\text{side}} \setminus \dagger V_i^-$  is not a strict entrance set. Even if this set was a strict entrance set, the set  $\bigcup_{y \in \dagger \mathcal{Q}_i \setminus \dagger V_{i-1}^-} C_{i,y}$  is not (necessarily) a part of strict slow entrance set  $S_\partial^{++}$ . Indeed, after perturbation, the flow along

the connecting orbit can leave the neighborhood  $\dagger\mathbf{N}$ , even though its  $\alpha$ -limit set does strictly enter  $\dagger\mathbf{N}$ .

The second deviation from Theorem A.7 is that we have defined the exit set  $\dagger\mathbf{L}$  in a different way. Instead of using  $\bigcup_{y \in \dagger\mathcal{V}^-} W^u(y)$  (where  $\dagger\mathcal{V}^- := \bigcup_{i=1}^I \dagger\mathcal{V}_i^-$ ), we chose a larger set  $\bigcup_{y \in \dagger\mathcal{V}^-} \dagger\mathbf{N}_y$  consisting of all fibers which project to  $\dagger\mathcal{V}^-$ .

We will deal with the first problem in two steps. First we modify (“shave”) flow boxes  $\dagger U_i$  in such a way, that all points in  $\dagger U_i^{\text{side}} \setminus \dagger V_i^-$  are strict entrance points. This can be done by arbitrarily small perturbations of the sets  $\dagger U_i$ . Based on this new collection of sets  $\dagger U_i$ , we build sets  $(\dagger\bar{\mathbf{N}}, \dagger\bar{\mathbf{L}})$  in analogous way to  $(\dagger\mathbf{N}, \dagger\mathbf{L})$ . We then show that the pair  $(\dagger\bar{\mathbf{N}}, \dagger\bar{\mathbf{L}})$  is homotopically equivalent to  $(\dagger\mathbf{N}, \dagger\mathbf{L})$ .

The second step is to modify the flow in the neighborhood of the set of connecting orbits  $\bigcup_{i=1}^I \bigcup_{y \in \dagger\mathcal{Q}_i \setminus \dagger\mathcal{V}_{i-1}^-} C_{i,y}$  in such a way that this set is a strict slow entrance set. With this new flow we essentially repeat the proof of Theorem A.7 ([16]) with the exit set defined using  $\bigcup_{y \in \dagger\mathcal{V}^-} \dagger\mathbf{N}_y$  instead of  $\bigcup_{y \in \dagger\mathcal{V}^-} W^u(y)$ . This will solve the second problem and we will show that  $(\dagger\bar{\mathbf{N}}, \dagger\bar{\mathbf{L}})$  is a singular index pair for the modified flow.

To finish the proof we homotope the modified flow to the original flow and show that the set  $\bigcup_{i=1}^I \bigcup_{y \in \dagger\mathcal{Q}_i \setminus \dagger\mathcal{V}_{i-1}^-} C_{i,y}$  is part of C-slow entrance set throughout the homotopy. This implies that  $\dagger\bar{\mathbf{N}}$  is a singular isolating neighborhood throughout the homotopy, hence it is isolating the same invariant set and the index is preserved. Thus  $(\dagger\bar{\mathbf{N}}, \dagger\bar{\mathbf{L}})$  is a singular index pair for the original flow as well.

We modify  $\dagger U_i^{\text{side}}$  slightly inside the set  $\dagger V_i^+$ . By assumption (5.4)

$$\dagger U_i^{\text{side}} \setminus \dagger V_i^- \subset \text{int}_{\dagger U_i} \dagger V_i^+. \quad (\text{B.4})$$

We want to shave  $\dagger U_i$  in such a way that all points in  $\dagger U_i^{\text{side}} \setminus \dagger V_i^-$  are strict entrance points. Reparameterize  $\dagger U_i$  so that

$$\dagger U_i \cong \mathbb{D}^{\ell-1} \times [0, 1]$$

where  $\dagger U_i^{\text{in}} \cong \mathbb{D}^{\ell-1} \times \{0\}$  and  $\dagger U_i^{\text{out}} \cong \mathbb{D}^{\ell-1} \times \{1\}$ . In this reparameterization the slow flow  $\varphi_i^{\text{slow}}$  is parallel to the second variable. Since both  $\dagger U_i^{\text{side}}$  and  $\dagger V_i^-$  are flow boxes under  $\varphi_i^{\text{slow}}$ , we can identify

$$\dagger U_i^{\text{side}} \setminus \dagger V_i^- =: Y \times [0, 1].$$

Further, we separate radial coordinate on  $\mathbb{D}^{\ell-1}$  by setting  $\mathbb{D}^{\ell-1} \cong (\mathbb{S}^{\ell-1} \times [0, 1]) / \mathbb{S}^{\ell-1} \times \{0\}$ . Then the set  $Y \subset \mathbb{S}^{\ell-1} \times \{1\}$ . From (B.4) follows that there is a  $\delta$ -neighborhood  $B_{\mathbb{S}^{\ell-1}}(Y, \delta)$  in  $\mathbb{S}^{\ell-1}$  such that

$$B_{\mathbb{S}^{\ell-1}}(Y, \delta) \times [0, 1] \subset \dagger V_i^+ \cap \dagger U_i^{\text{side}}.$$

It also follows from (B.4) that there is  $\zeta_i > 0$  such that

$$Y \times [1 - 2\zeta_i, 1] \times [0, 1] \subset \text{int} \dagger V_i^+.$$

Define a bump function  $\rho : \mathbb{S}^{\ell-1} \times \{1\} \rightarrow [0, 1]$  such that

$$\rho(y) := \begin{cases} 1 & y \in Y \\ 0 & y \notin B_{\mathbb{S}^{\ell-1}}(Y, \delta). \end{cases}$$

We define an isotopy  $H_i : \mathbb{S}^{\ell-1} \times [0, 1] \times [0, 1] \times [0, 1] \rightarrow \mathbb{S}^{\ell-1} \times [0, 1] \times [0, 1]$  by

$$H_i(y, r, s, t) = (y, \rho(y)q(r, s, t), s)$$

where  $r$  is radial direction in  $D^{\ell-1}$ ,  $s$  is direction along  $\dagger U_i$  in direction of flow  $\varphi_i^{\text{slow}}$  and  $t$  is isotopy parameter. Finally, the function  $q(r, s, t)$  is given by

$$q(r, s, t) := \begin{cases} [tr + (1-t)(1-2\zeta_i)](1-s) + s & \text{if } r \geq 1 - 2\zeta_i \\ r & \text{if } r < 1 - 2\zeta_i. \end{cases}$$

Observe, that the first three variables in  $H_i$  describe coordinates of a point in  $\dagger U_i$  while the last one is the isotopy parameter. We write

$$h_i^t(u) := H_i(y, r, s, t)$$

where  $u = (y, r, s) \in \dagger U_i$ . Then we note that  $h_i^1(\dagger U_i) = \dagger U_i$  and  $h_i^0(\dagger U_i^{\text{side}} \setminus \dagger V_i^-)$  consists of strict entrance point under the flow  $\varphi_i^{\text{slow}}$ . Let  $h_i := h_i^0$  and

$$\dagger \bar{U}_i := h_i(\dagger U_i), \quad \dagger \bar{V}_i^\pm := h_i(\dagger V_i^\pm)$$

be the images of these sets under  $h_i$ .

We want to extend the family of homeomorphisms  $h_i$ ,  $i = 0, \dots, I$  to the neighborhood  $N$ . We first define a new homeomorphism  $\tilde{h}_i : \dagger \mathcal{U}_i \rightarrow \dagger \bar{\mathcal{U}}_i$  by

$$\tilde{h}_i := \Pi \circ h_i,$$

and let  $\widetilde{\dagger \mathcal{U}}_i := \tilde{h}_i(\dagger \mathcal{U}_i)$  be the shaved set  $\dagger \bar{\mathcal{U}}_i$ .

We have to address the issue of consistency. Since  $\dagger \mathcal{U}_i \cap \dagger \mathcal{U}_{i-1} = \dagger \mathcal{B}_i$ , for points in  $\dagger \mathcal{B}_i$  both  $\tilde{h}_i$  and  $\tilde{h}_{i-1}$  may be defined there. More specifically, the isotopy  $H_i$  effects a  $2\zeta_i$ -neighborhood of the set  $\dagger U_i^{\text{side}} \setminus \dagger V_i^- \subset \text{int}_{\dagger U_i} \dagger V_i^+$ . Therefore, the map  $\tilde{h}_i$  effects points in  $\dagger \mathcal{U}_i^{\text{side}} \cap \dagger \mathcal{V}_i^+$ . Similarly, the map  $\tilde{h}_{i-1}$  effects points in  $\dagger \mathcal{U}_{i-1}^{\text{side}} \cap \dagger \mathcal{V}_{i-1}^+$ . We need to show that these two sets do not intersect in  $\dagger \mathcal{B}_i$  if  $\zeta_i$ , given in the definition of  $q$ , is sufficiently small. This is resolved in the following lemma.

**Lemma B.2**  $\dagger \mathcal{U}_i^{\text{side}} \cap \dagger \mathcal{V}_i^+ \cap \dagger \mathcal{B}_i \subset \text{int} \dagger \mathcal{U}_{i-1} \cup \text{int} \dagger \mathcal{U}_{i-1}^{\text{in}} \cup \text{int}_{\dagger \mathcal{U}_{i-1}} \dagger \mathcal{V}_{i-1}^-$ .

*Proof.* Since  $\dagger\mathcal{U}_i \cap \dagger\mathcal{U}_{i-1} = \dagger\mathcal{B}_i$  we have that

$$\dagger\mathcal{U}_i^{\text{side}} \cap \dagger\mathcal{V}_i^+ \cap \dagger\mathcal{B}_i \subset \dagger\mathcal{U}_{i-1}.$$

We write  $\dagger\mathcal{U}_{i-1} = \text{int}\dagger\mathcal{U}_{i-1} \cup \partial\dagger\mathcal{U}_{i-1}$  and

$$\partial\dagger\mathcal{U}_{i-1} = \text{int}\dagger\mathcal{U}_{i-1}^{\text{in}} \cup \text{int}\dagger\mathcal{U}_{i-1}^{\text{out}} \cup \dagger\mathcal{U}_{i-1}^{\text{side}}.$$

Clearly  $\dagger\mathcal{U}_{i-1}^{\text{out}} \cap \dagger\mathcal{B}_i = \emptyset$ . Now by assumption (5.4) we have

$$\dagger\mathcal{U}_{i-1}^{\text{side}} \subset \text{int}_{\dagger\mathcal{U}_{i-1}} \dagger\mathcal{V}_{i-1}^- \cup \text{int}_{\dagger\mathcal{U}_{i-1}} \dagger\mathcal{V}_{i-1}^+.$$

Together, this implies

$$(\dagger\mathcal{U}_i^{\text{side}} \cap \dagger\mathcal{V}_i^+ \cap \dagger\mathcal{B}_i) \subset \text{int}\dagger\mathcal{U}_{i-1} \cup \text{int}\dagger\mathcal{U}_{i-1}^{\text{in}} \cup \text{int}_{\dagger\mathcal{U}_{i-1}} \dagger\mathcal{V}_{i-1}^- \cup \text{int}_{\dagger\mathcal{U}_{i-1}} \dagger\mathcal{V}_{i-1}^+.$$

We finish the proof of this lemma by showing that  $\dagger\mathcal{B}_i \cap \text{int}_{\dagger\mathcal{U}_{i-1}} \dagger\mathcal{V}_{i-1}^+ = \emptyset$ . Indeed, if  $y \in \text{int}_{\dagger\mathcal{U}_{i-1}} \dagger\mathcal{V}_{i-1}^+$  then the trajectory  $\varphi_{i-1}^{\text{slow}}(\Pi^{-1}(y), -t)$  of the reversed slow flow on  $\dagger\mathcal{U}_{i-1}$  exits  $\dagger\mathcal{U}_{i-1}$  without intersecting  $\dagger\mathcal{B}'_{i-1}$ . Therefore  $\text{int}_{\dagger\mathcal{U}_{i-1}} \dagger\mathcal{V}_{i-1}^+ \cap \dagger\mathcal{B}'_{i-1} = \emptyset$ , and, after projecting to  $\mathbb{R}^\ell$ ,  $\text{int}_{\dagger\mathcal{U}_{i-1}} \dagger\mathcal{V}_{i-1}^+ \cap \dagger\mathcal{B}_i = \emptyset$ .  
Therefore

$$\dagger\mathcal{U}_i^{\text{side}} \cap \dagger\mathcal{V}_i^+ \cap \dagger\mathcal{B}_i \subset \text{int}\dagger\mathcal{U}_{i-1} \cup \text{int}\dagger\mathcal{U}_{i-1}^{\text{in}} \cup \text{int}_{\dagger\mathcal{U}_{i-1}} \dagger\mathcal{V}_{i-1}^-. \quad (\text{B.5})$$

□

From this lemma it follows that the domains of homeomorphisms  $\tilde{h}_i$  for sufficiently small choice of  $\zeta_i$  are disjoint. Therefore there is a well defined homeomorphism

$$\tilde{h}(y) := \tilde{h}_i(y) \text{ for } y \in \dagger\mathcal{U}_i.$$

We extend  $\tilde{h}$  to entire neighborhood  $\dagger\mathbf{N}$  by

$$\eta(x, y) := (x, \tilde{h}_i(y))$$

for  $(x, y) \in \dagger\mathbf{N}$  and  $y \in \dagger\mathcal{U}_i$ . Notice that  $\eta$  is homotopic to the identity using a homotopy induced from a collection of isotopies  $H_i$ ,  $i = 0, \dots, I$ . Let

$$\dagger\bar{\mathbf{N}} := \eta(\dagger\mathbf{N}), \quad \dagger\bar{\mathbf{L}} := \eta(\dagger\mathbf{L}).$$

We note that the isotopies  $H_i$  do not effect the caps  $\dagger\mathbf{C}_R$  and  $\dagger\mathbf{C}_A$ , and therefore,  $\eta$  induces an isomorphism

$$\eta^* : H^*(\dagger\bar{\mathbf{N}}, \dagger\bar{\mathbf{L}}) \rightarrow H^*(\dagger\mathbf{N}, \dagger\mathbf{L}).$$

Our next observation is that during a homotopy of the map  $\eta$  to the identity only points in  $\text{int}\dagger\mathcal{V}_i^+$  are affected. These points leave  $\dagger\mathbf{N}$  in finite time under the backward flow  $\varphi_i^{\text{slow}}(y, -t)$ . It follows that throughout the homotopy the

intermediate sets  $\dagger\mathbf{N}^t$  are singular isolating neighborhoods. In particular,  $\dagger\mathbf{N}^0 = \dagger\mathbf{N}$  isolates  $\text{Inv}(\dagger\mathbf{N})$ .

It follows from (B.5) that for sufficiently small  $\zeta_i$  (B.5) holds also for the pair  $(\dagger\bar{\mathbf{N}}, \dagger\bar{\mathbf{L}})$ . Therefore the new set  $\dagger\bar{\mathbf{L}}$  has the same structure as the set  $\dagger\mathbf{L}$ . In particular, for a heteroclinic corridor we have

$$\begin{aligned} \dagger\bar{\mathbf{L}} &:= \rho(\text{cl}(\dagger\bar{\mathbf{N}}^-), \dagger\bar{\mathbf{N}}, \varphi^0) \cup \bigcup_{y \in \text{cl}(\dagger C_R^L)} \dagger\bar{\mathbf{N}}_y \cup \bigcup_{y \in \dagger C_A^L} \dagger\bar{\mathbf{N}}_y \\ &\cup \left( \bigcup_{i=1}^I W_{\dagger\mathbf{B}(i)}^u(\dagger\bar{U}_i^{\text{out}}) \right) \cup \left( \bigcup_{i=0}^I \bigcup_{y \in \dagger\bar{V}_i^-} \dagger\bar{\mathbf{N}}_y \right). \end{aligned} \quad (\text{B.6})$$

and for a periodic corridor

$$\dagger\bar{\mathbf{L}} := \rho(\text{cl}(\dagger\bar{\mathbf{N}}^-), \dagger\bar{\mathbf{N}}, \varphi^0) \cup \left( \bigcup_{i=1}^I W_{\dagger\mathbf{B}(i)}^u(\dagger\bar{U}_i^{\text{out}}) \right) \cup \left( \bigcup_{i=0}^I \bigcup_{y \in \dagger\bar{V}_i^-} \dagger\bar{\mathbf{N}}_y \right). \quad (\text{B.7})$$

We summarize the first step of the construction. Given sets  $(\dagger\mathbf{N}, \dagger\mathbf{L})$  we found a pair  $(\dagger\bar{\mathbf{N}}, \dagger\bar{\mathbf{L}})$  which is homotopically equivalent to  $(\dagger\mathbf{N}, \dagger\mathbf{L})$ , isolates the same invariant set and

$$\dagger\bar{U}_i^{\text{side}} \setminus \dagger\bar{V}_i^-$$

is strict entrance set under  $\varphi_i^{\text{slow}}$  for all  $i$ . Using Remark B.1 and the construction above, in the new pair  $(\dagger\bar{\mathbf{N}}, \dagger\bar{\mathbf{L}})$  the part

$$\bigcup_{i=0}^I \dagger\bar{U}_i^{\text{in}} \cup \bigcup_{i=0}^I \dagger\bar{U}_i^{\text{side}} \setminus \dagger\bar{V}_i^- \quad (\text{B.8})$$

of the set  $\mathbf{S}^+$  is actually a subset of strict entrance set  $S_\delta^{++}$ .

We need to address the last part of the set  $\mathbf{S}^+$  and that is the set

$$\bigcup_{i=1}^I \bigcup_{y \in \dagger\bar{Q}_i \setminus \dagger\bar{V}_{i-1}^-} C_{i,y}.$$

This brings us to the second step in the proof. Let  $C_i^o := \bigcup_{y \in \dagger\bar{Q}_i \setminus \dagger\bar{V}_{i-1}^-} C_{i,y}$ .

We modify the flow in the neighborhood of the set  $\bigcup_{i=1}^I C_i^o$ . We fix  $i$  and do a modification in the neighborhood of the set  $C_i^o$ . This modification can be done in the same way in the neighborhood of the other sets  $C_j^o$ ,  $j \neq i$ .

Given  $w \in \mathbb{R}^\ell$  and  $\rho > 0$ , let  $B_\rho(w) := \{y \in \mathbb{R}^\ell \mid \|w - y\| < \rho\}$  and given a set  $Z \subset \mathbb{R}^\ell$ , let  $B_\rho(Z) := \bigcup_{w \in Z} B_\rho(w)$ . Let  $c_i := \Pi(C_i^o) \subset \mathbb{R}^\ell$ . Take  $\delta > 0$ , sufficiently small, and let

$$Y_\delta^i := B_\delta(\Pi(c_i)).$$



Notice that  $Y_\delta^i$  is a neighborhood in the space of slow variables  $\mathbb{R}^\ell$ . The set  $C_i^o$  is the set of connecting orbits in the fast flow, that connect the invariant manifolds  $M_2^i$  to  $M_1^i$ . These manifolds are, locally in a neighborhood of  $C^0(i)$ , given by functions  $m_1^i(y)$  and  $m_2^i(y)$ , respectively. The slow flow on these manifolds is given by

$$\dot{y} := g(m_1^i(y), y) \quad \text{and} \quad \dot{y} := g(m_2^i(y), y), \quad (\text{B.9})$$

respectively (compare (1.1)). Clearly,

$$\dagger\bar{\mathcal{Q}}_i \setminus \dagger\bar{\mathcal{V}}_{i-1}^- \subset \dagger\bar{\mathcal{U}}_i^{\text{side}} \cap \dagger\bar{\mathcal{V}}_i^+ \cap \dagger\bar{\mathcal{B}}_i.$$

Since (B.5) holds for new pair  $(\dagger\bar{\mathbf{N}}, \dagger\bar{\mathbf{L}})$  we have

$$\dagger\bar{\mathcal{Q}}_i \setminus \dagger\bar{\mathcal{V}}_{i-1}^- \subset \text{int}\dagger\mathcal{U}_{i-1} \cup \text{int}\dagger\mathcal{U}_{i-1}^{\text{in}}.$$

For a point  $(x, y)$  with  $y \in (\dagger\bar{\mathcal{Q}}_i \setminus \dagger\bar{\mathcal{V}}_{i-1}^-) \cap \text{int}\dagger\mathcal{U}_{i-1}^{\text{in}}$  define a function  $G(x, y)$  as follows. For  $y \in Y_\delta^i$  and  $x = tm_1^i(y) + (1-t)m_2^i(y)$ , set

$$G(x, y) := tg(m_1^i(y), y) + (1-t)g(m_2^i(y), y). \quad (\text{B.10})$$

For  $(x, y)$  with  $y \in (\dagger\bar{\mathcal{Q}}_i \setminus \dagger\bar{\mathcal{V}}_{i-1}^-) \cap \text{int}\dagger\mathcal{U}_{i-1}$  we define  $G(x, y)$  slightly differently. Let  $y \in Y_\delta^i$  and let  $(x^*(y), y)$ ,  $h_2^i(y) > x^*(y) > h_1^i(y)$ , be a point such that for all  $x = tx^*(y) + (1-t)m_1^i(y)$  we have  $(x, y) \in \text{int}\dagger\mathcal{U}_{i-1}$ . Such  $x^*(y)$  exists since  $\dagger\mathcal{U}_{i-1}$  is a tubular neighborhood of  $\dagger\mathcal{U}_{i-1}$  and  $(m_1^i(y), y) \in \dagger\mathcal{U}_{i-1}$ . Then

$$G(x, y) := \begin{cases} g(m_2^i(y), y) & \text{if } x \geq x^*(y) \\ tg(m_1^i(y), y) + (1-t)g(m_2^i(y), y) & \text{if } x = tx^*(y) + (1-t)m_1^i(y). \end{cases} \quad (\text{B.11})$$

We define a family of bump functions  $\Omega_\delta^i : \mathbb{R}^\ell \rightarrow [0, 1]$  such that

- $\text{supp } \Omega_\delta^i \subset Y_\delta$ ,
- $B_{\delta/2}(c_i) \subset (\Omega_\delta^i)^{-1}(1)$ .

We modify the original system (1.1) as follows

$$\begin{aligned} \dot{x} &= f(x, y) \\ \dot{y} &= \epsilon[\Omega_\delta G(x, y) + (1 - \Omega_\delta)g(x, y)]. \end{aligned} \quad (\text{B.12})$$

Observe that if the  $y$ -component of a point  $(x, y)$  is in the  $\delta/2$  neighborhood of  $\bigcup_i C_i^o$ , then the second equation becomes

$$\dot{y} = \epsilon G(x, y). \quad (\text{B.13})$$

Since both vector fields (B.9) point strictly into the set  $\dagger\bar{\mathbf{N}}$ , the vector field (B.13) with function  $G$  given by (B.10), as a linear combination, also points strictly into the set  $\dagger\bar{\mathbf{N}}$  in the  $\delta/2$  neighborhood of  $\bigcup_i C_i^o$ . The vector field (B.13) with function  $G$  given by (B.11) points strictly into  $\dagger\bar{\mathbf{N}}$  for  $x \geq x^*(y)$

since the boundary of  $\dagger\bar{\mathbf{N}}$  is parallel to the boundary of  $\dagger\bar{\mathbf{N}} \cap \dagger\mathbf{U}_i$  and  $g(h_2^i(y), y)$  points strictly into  $\dagger\bar{\mathbf{N}} \cap \dagger\mathbf{U}_i$ . The second part of definition (B.11) effects only points in the interior of  $\dagger\bar{\mathbf{N}}$ .

Since we have only changed the  $\epsilon$  terms in the flow (1.1) the maximal invariant set in  $\bigcup_i Y_\delta^i$  remains the same. It follows that all the arguments in Lemma 5.8 and Lemma 5.9 remain valid for the modified system (B.12). Furthermore, by construction the set  $\bigcup_i C_i^o$  is now a part of a strict slow entrance set. This finishes the second step of the construction.

In the last step we show, following an argument in [16], that the new pair  $(\dagger\bar{\mathbf{N}}, \dagger\bar{\mathbf{L}})$  is a singular index pair under the modified flow (B.12). We introduce some notation from [16]. Define

$$Q_\nu^- := B_\nu(\cup_{z \in S_\delta^-} \mathfrak{R}(K_z)), \quad Q_\nu^+ := B_\nu(S_\delta^+), \quad (\text{B.14})$$

where  $B_\nu$  is now a  $\nu$  neighborhood on the full phase space  $\mathbb{R}^n$ . We set  $Q_\nu = Q_\nu^- \cup Q_\nu^+$ . Define a family of smooth bump functions  $\mu_\nu : \mathbb{R}^n \rightarrow [0, 1]$  such that

- $\text{supp } \mu_\nu \subset Q_\nu$ ,
- $B_{\nu/2}(\cup_{z \in S_\delta^-} \mathfrak{R}(K_z)) \subset \mu_\nu^{-1}(1)$ .

Consider the two parameter singular perturbation problem given by the equation

$$\dot{z} = F(z, \epsilon, \nu) = F_0(z) + \mu_\nu(z)\epsilon F_1(z),$$

where  $z = (x, y)$  and

$$F_0 := \begin{pmatrix} f(x, y) \\ 0 \end{pmatrix} \text{ and } F_1 := \begin{pmatrix} 0 \\ g(x, y) \end{pmatrix},$$

and let  $\psi_\nu^\epsilon$  denote its flow. Notice that for  $\nu$  sufficiently large  $\psi_\nu^\epsilon = \varphi^\epsilon$ . We first observe that  $\dagger\bar{\mathbf{N}}$  is an isolating neighborhood for flows  $\psi_\nu^\epsilon$  for small enough  $\epsilon$  and  $\nu$ .

**Lemma B.3 ([16]Lemma 3.7)** *Assume that  $S_\delta$  consists of  $C$ -slow entrance and exit points and let  $r$  be a diameter of  $\dagger\bar{\mathbf{N}}$ . Then there is a continuous function  $\tilde{\epsilon} : (0, r] \rightarrow (0, \infty)$  with the property that  $\dagger\bar{\mathbf{N}}$  is an isolating neighborhood for  $\psi_\nu^\epsilon$  for all  $(\nu, \epsilon)$  such that  $0 < \nu \leq r$  and  $0 < \epsilon \leq \tilde{\epsilon}(\nu)$ .*

Now we consider singular index pair. Let

$$\dagger\bar{\mathbf{L}}_\nu^\epsilon := \text{cl}(\rho(\text{cl}(Q_\nu^-), \dagger\bar{\mathbf{N}}, \psi_\nu^\epsilon)) \cup \text{cl}(\rho(\text{cl}(\dagger\bar{\mathbf{N}}^-), \dagger\bar{\mathbf{N}}, \varphi^0)).$$

**Lemma B.4** *There exists  $\bar{\nu} > 0$  such that given  $\nu \in (0, \bar{\nu}]$ , there is an  $\bar{\epsilon} > 0$  such that for  $\epsilon \in (0, \bar{\epsilon}]$*

$$(\dagger\bar{\mathbf{N}}, \dagger\bar{\mathbf{L}}_\nu^\epsilon \cup \dagger\bar{\mathbf{L}}^{\text{slow}})$$

*is an index pair for  $\psi_\nu^\epsilon$ .*

*Proof.* This proof is motivated by the proof of Lemma 3.8 of [16].

**Step 1:** By definition  $\dagger\bar{\mathbf{L}}_\nu^\epsilon$  is closed. Since  $\dagger\bar{\mathbf{L}}^{\text{slow}}$  is closed trivially, the first condition in the definition of an index pair is satisfied.

**Step 2:** We need to show that  $\dagger\bar{\mathbf{L}}_\nu^\epsilon \cup \dagger\bar{\mathbf{L}}^{\text{slow}}$  is positively invariant for  $\psi_\nu^\epsilon$ . The proof for  $\dagger\bar{\mathbf{L}}_\nu^\epsilon$  is found in Lemma 3.8 of [16]. Assume  $z_0 \in \dagger\bar{\mathbf{L}}^{\text{slow}}$  and  $z := \psi_\nu^\epsilon(t, z_0) \in \dagger\bar{\mathbf{N}}$ . We need to show that  $z \in \dagger\bar{\mathbf{L}}_\nu^\epsilon \cup \dagger\bar{\mathbf{L}}^{\text{slow}}$ . If  $\psi_\nu^\epsilon([0, t], z_0) \cap Q_\nu^- \neq \emptyset$ , then also  $\psi_\nu^\epsilon([0, t], z_0) \cap \dagger\bar{\mathbf{L}}_\nu^\epsilon \neq \emptyset$  and by positive invariance of  $\dagger\bar{\mathbf{L}}_\nu^\epsilon$  we have  $z \in \dagger\bar{\mathbf{L}}_\nu^\epsilon$ . So assume  $\psi_\nu^\epsilon([0, t], z_0) \cap Q_\nu^- = \emptyset$ . Then  $\psi_\nu^\epsilon = \varphi^0$  and  $z = \varphi^0(t, z_0)$ . Since the set  $\dagger\bar{\mathbf{L}}^{\text{slow}}$  is positively invariant under the flow  $\varphi^0$ , we have  $z \in \dagger\bar{\mathbf{L}}^{\text{slow}}$ .

**Step 3:** We need to show that  $\dagger\bar{\mathbf{L}}_\nu^\epsilon \cup \dagger\bar{\mathbf{L}}^{\text{slow}}$  is an exit set. For  $\bar{\nu} > 0$  sufficiently small and  $\nu < \bar{\nu}$ , no orbit can leave through  $Q_\nu^+$  since the slow entrance points are, in fact, strict slow entrance points. Let  $z_0 \in \dagger\bar{\mathbf{N}}$  and assume that  $\psi_\nu^\epsilon(t_0, z_0) \notin \dagger\bar{\mathbf{N}}$ . If

$$\psi_\nu^\epsilon([0, t_0], z_0) \cap Q_\nu = \emptyset,$$

then there is  $t_1 \in [0, t_0]$  such that  $\psi_\nu^\epsilon(t_1, z_0) \in \dagger\bar{\mathbf{N}}^-$  and  $\psi_\nu^\epsilon([0, t_1], z_0) \in \dagger\bar{\mathbf{N}}$ , since  $\psi_\nu^\epsilon = \varphi^0$  on  $\dagger\bar{\mathbf{N}} \setminus Q_\nu$ . So assume that the forward trajectory does not leave through  $\dagger\bar{\mathbf{N}} \setminus Q_\nu$ . By the choice of  $\nu$ , the forward trajectory through  $z_0$  leaves through  $Q_\nu^-$ , which is a subset of  $\dagger\bar{\mathbf{L}}_\nu^\epsilon$ .  $\square$

The following result follows from Lemma 3.9 [16].

**Lemma B.5** *There is sequence  $\nu_i$  decreasing to zero and a choice of  $\epsilon(\nu_i) \in (0, \bar{\epsilon}(\nu_i)]$  such that  $\dagger\bar{\mathbf{L}}_{\nu_{i+1}}^{\epsilon(\nu_{i+1})} \subset \dagger\bar{\mathbf{L}}_{\nu_i}^{\epsilon(\nu_i)}$ .*

**Lemma B.6**  $\bigcap_{i \geq 1} \dagger\bar{\mathbf{L}}_{\nu_i}^{\epsilon(\nu_i)} \cup \dagger\bar{\mathbf{L}}^{\text{slow}} = \dagger\bar{\mathbf{L}}^{\text{fast}} \cup \dagger\bar{\mathbf{L}}^{\text{slow}}$ .

*Proof.* By Lemma 3.10 [16] we get that the first line in following computation.

$$\begin{aligned} \bigcap_{i \geq 1} \dagger\bar{\mathbf{L}}_{\nu_i}^{\epsilon(\nu_i)} \cup \dagger\bar{\mathbf{L}}^{\text{slow}} &= \rho((\text{cl}(\dagger\bar{\mathbf{N}}^-), \dagger\bar{\mathbf{N}}, \varphi^0) \cup \bigcup_{i=1}^I W_{\dagger\bar{\mathbf{N}}}^u(\mathbf{S}^-) \cup \dagger\bar{\mathbf{L}}^{\text{slow}} \\ &= \rho((\text{cl}(\dagger\bar{\mathbf{N}}^-), \dagger\bar{\mathbf{N}}, \varphi^0) \cup \bigcup_{i=0}^I W_{\dagger\bar{\mathbf{N}}}^u(\dagger\bar{\mathcal{U}}_i^{\text{out}}) \cup \bigcup_{i=0}^I W_{\dagger\bar{\mathbf{N}}}^u(\dagger\bar{\mathcal{V}}_i^-) \\ &\cup \bigcup_{i=1}^I \bigcup_{y \in \dagger\bar{\mathcal{Q}}_i \cap \dagger\bar{\mathcal{V}}_{i-1}^-} C_{i,y} \cup \dagger\bar{\mathbf{L}}^{\text{slow}}. \end{aligned}$$

The first two terms in last line form the set  $\dagger\bar{\mathbf{L}}^{\text{fast}}$  while all other are subsets of  $\dagger\bar{\mathbf{L}}^{\text{slow}}$ .  $\square$

**Theorem B.7** *Let  $\dagger\bar{\mathbf{N}}$  be a singular isolating neighborhood defined above. Assume*

(1)  $S_{\partial}^-$  consists of  $C$ -slow exit points.

(2)  $S_{\partial} \subset S_{\partial}^{++} \cup S_{\partial}^-$ .

(3)  $(S_{\partial}^{++} \setminus S_{\partial}^-) \cap \text{cl}(\dagger\bar{\mathbf{N}}^-) = \emptyset$ .

Let  $\dagger\bar{\mathbf{L}}$  be defined as in (B.6) for heteroclinic corridor or as in (B.7) for periodic corridor.

If  $\dagger\bar{\mathbf{L}}$  is closed, then  $(\dagger\bar{\mathbf{N}}, \dagger\bar{\mathbf{L}})$  is a singular index pair for family of flows (B.12).

*Proof.* Let  $r$  be a diameter of the set  $\dagger\bar{\mathbf{N}}$ . Let  $G := \{(\nu, \epsilon) \mid 0 < \nu \leq r, 0 < \epsilon \leq \tilde{\epsilon}(\nu)\}$ . By weak continuity property of the Alexander-Spanier cohomology [20], the inclusion maps  $\iota_i : (\dagger\bar{\mathbf{N}}, \dagger\bar{\mathbf{L}}) \rightarrow (\dagger\bar{\mathbf{N}}, \dagger\bar{\mathbf{L}}_{\nu_i}^{\epsilon(\nu_i)} \cup \dagger\bar{\mathbf{L}}^{\text{slow}})$  induce an isomorphism

$$\lim_{\rightarrow} H^*(\dagger\bar{\mathbf{N}}, \dagger\bar{\mathbf{L}}_{\nu_i}^{\epsilon(\nu_i)} \cup \dagger\bar{\mathbf{L}}^{\text{slow}}) \cong H^*(\dagger\bar{\mathbf{N}}, \dagger\bar{\mathbf{L}}),$$

where we use Lemma B.6, the fact that  $\bigcup_{i=0}^I W_{\dagger\bar{\mathbf{N}}}^u(\dagger\bar{V}_i) \subset \dagger\bar{\mathbf{L}}^{\text{slow}}$  and that  $\dagger\bar{\mathbf{L}} = \dagger\bar{\mathbf{L}}^{\text{slow}} \cup \dagger\bar{\mathbf{L}}^{\text{fast}}$ . On the other hand, by the standard continuation theorem for the Conley index, for  $(\nu, \epsilon), (\nu', \epsilon') \in G$ , we have

$$CH^*(\text{Inv}(\dagger\bar{\mathbf{N}}, \psi_{\nu}^{\epsilon})) \cong CH^*(\text{Inv}(\dagger\bar{\mathbf{N}}, \psi_{\nu'}^{\epsilon'})),$$

which by Lemma B.4 is the same as

$$H^*(\dagger\bar{\mathbf{N}}, \dagger\bar{\mathbf{L}}_{\nu}^{\epsilon} \cup \dagger\bar{\mathbf{L}}^{\text{slow}}) \cong H^*(\dagger\bar{\mathbf{N}}, \dagger\bar{\mathbf{L}}_{\nu'}^{\epsilon'} \cup \dagger\bar{\mathbf{L}}^{\text{slow}}).$$

This implies

$$H^*(\dagger\bar{\mathbf{N}}, \dagger\bar{\mathbf{L}}_r^{\epsilon(r)} \cup \dagger\bar{\mathbf{L}}^{\text{slow}}) \cong H^*(\dagger\bar{\mathbf{N}}, \dagger\bar{\mathbf{L}})$$

and so  $(\dagger\bar{\mathbf{N}}, \dagger\bar{\mathbf{L}})$  is a singular index pair.  $\square$

## B.4 Proof of Propositions 5.12 and 5.13

We first verify the assumptions of Theorem B.7 to conclude that the pair  $(\dagger\bar{\mathbf{N}}, \dagger\bar{\mathbf{L}})$  is an index pair for the flow (B.12).

We show first that  $\dagger\bar{\mathbf{L}}$  is closed. Since  $\dagger\mathcal{V}_i^-$  is closed, clearly  $\dagger\bar{\mathbf{L}}^{\text{slow}} = \bigcup_{i=0}^I \bigcup_{y \in \dagger\mathcal{V}_i^-} \dagger\bar{\mathbf{N}}_y$  is closed.

We now consider the set  $\rho(\text{cl}(\dagger\bar{\mathbf{N}}^-), \dagger\bar{\mathbf{N}}, \varphi^0)$ . Observe that if  $(x, y) \in \dagger\bar{\mathbf{N}}^-$ , then  $\rho((x, y), \dagger\bar{\mathbf{N}}, \varphi^0) = (x, y)$ . So consider  $(x, y) \in \text{cl}(\dagger\bar{\mathbf{N}}^-) \setminus \dagger\bar{\mathbf{N}}^-$ . Then,  $x \in \dagger\bar{\mathbf{U}}_y^-(i) \cap \dagger\bar{\mathbf{B}}_y$  where  $y \in \widehat{\mathcal{U}}_i^{\text{out}}$  for some  $i$ . By (5.15) this implies that

$$y \in (\widehat{\mathcal{U}}_i^{\text{out}} \setminus \dagger\bar{\mathbf{B}}_i) \cup \dagger\bar{\mathbf{B}}_i^{\text{in}} \cup \dagger\bar{\mathcal{V}}_{i-1}^-.$$

If  $y \in \dagger\bar{\mathcal{V}}_{i-1}^-$ , then  $(x, y) \in \dagger\bar{\mathbf{L}}^{\text{slow}}$  which we discussed earlier.

If, on the other hand,  $y \in \dagger\bar{\mathcal{B}}^{\text{in}}$  then by assumption **(H2)** for the slow corridor

$$y \in \dagger\mathcal{R}_i^a \cup \dagger\mathcal{R}_i^b.$$

Therefore by Definition 5.1, the forward orbit of  $(x, y)$  leaves the set  $\dagger\bar{\mathbf{B}}_y$  in finite, uniformly bounded time. Finally, if  $y \in \dagger\bar{\mathcal{U}}_i^{\text{out}} \setminus \dagger\bar{\mathcal{B}}_i$  then  $(x, y) \in \dagger\bar{\mathbf{U}}_i \setminus \dagger\bar{\mathbf{B}}_i$  and the forward orbit of  $(x, y)$  also leaves the set  $\dagger\bar{\mathbf{U}}_i$  in finite, uniformly bounded time. Therefore,  $\rho((x, y), \dagger\bar{\mathbf{N}}, \varphi^0)$  is closed, which in turn implies that  $\rho(\text{cl}(\dagger\bar{\mathbf{N}}^-), \dagger\bar{\mathbf{N}}, \varphi^0)$  is closed.

Now we discuss the set  $W_{\dagger\bar{\mathbf{B}}_i}^u(\dagger\bar{\mathcal{U}}_i^{\text{out}})$ . By (5.14)

$$\dagger\bar{\mathcal{U}}_i^{\text{out}} \subset (\dagger\bar{\mathcal{U}}_i^{\text{out}} \setminus \dagger\bar{\mathcal{B}}_i) \cup \dagger\bar{\mathcal{B}}_i^{\text{out}} \cup \dagger\bar{\mathcal{V}}_{i-1}^-.$$

As above, if  $y \in \dagger\bar{\mathcal{V}}_{i-1}^-$  then  $(x, y) \in \dagger\bar{\mathbf{L}}^{\text{slow}}$  and we considered such points above. The case  $y \in \dagger\bar{\mathcal{U}}_i^{\text{out}} \setminus \dagger\bar{\mathcal{B}}_i$  was also discussed above. Finally, if  $y \in \dagger\bar{\mathcal{B}}_i^{\text{out}}$ , then by assumption **(H2)** for the slow corridor, we have

$$y \in \dagger\mathcal{R}_i^a \cup \dagger\mathcal{R}_i^b.$$

Therefore all trajectories in  $W_{\dagger\bar{\mathbf{B}}_i}^u(\dagger\bar{\mathcal{U}}_i^{\text{out}})$  leave the set  $\dagger\bar{\mathbf{N}}$  in finite time. It follows that  $W_{\dagger\bar{\mathbf{B}}(i)}^u(\dagger\bar{\mathcal{U}}_i^{\text{out}})$  is closed for each  $i$ . Therefore,  $\dagger\bar{\mathbf{L}}$  is closed.

Since the change (B.12) only effected the  $\epsilon$  terms in the flow (1.1), the maximal invariant set in  $\bigcup_i Y_\delta^i$  remains the same. It follows that all the arguments in Lemma 5.8 and Lemma 5.9 remain valid for the modified system (B.12) and therefore assumption (1) of Theorem B.7 is satisfied. Furthermore, by construction of (B.12) the set  $\bigcup_i C_i^o$  is now a part of a strict slow entrance set. In view of (B.8) and using Lemmas 5.8, 5.9, 5.10 and 5.11 assumptions (2) and (3) of Theorem B.7 are satisfied for the flow (B.12).

Thus we can conclude from Theorem B.7 that  $(\dagger\bar{\mathbf{N}}, \dagger\bar{\mathbf{L}})$  is singular index pair for flow (B.12).

To conclude the argument, we need to show that there is a homotopy from (B.12) to (1.1) such that the set  $\bigcup_i C_i^o$  is a C-slow entrance set. Then it follows from this and Lemmas 5.8, 5.9 that  $\dagger\bar{\mathbf{N}}$  is a singular isolating neighborhood throughout the homotopy. Consequently  $(\dagger\bar{\mathbf{N}}, \dagger\bar{\mathbf{L}})$  is a singular index pair for the original flow (1.1).

Consider a straight line homotopy

$$H(x, y, s) := sg(x, y) + (1 - s)(\Omega_\delta G(x, y) + (1 - \Omega_\delta)g(x, y)).$$

Since the homotopy effects only the  $\epsilon$  component of the flow,  $\bigcup_i C_i^o$  is the invariant set throughout the homotopy. The slow flow on the manifolds  $M_1^i$  and  $M_2^i$  is the same

$$\dot{y} := g(m_1^i(y), y) \quad \text{and} \quad \dot{y} := g(m_2^i(y), y),$$

respectively, throughout the homotopy. Since calculation to show that  $\bigcup_i C_i^o$  consists of C-slow entrance points only depends on the behavior of  $\omega$ -limit set under the slow flow, we see that this behavior does not change throughout the homotopy. Finally, Lemma 5.8 shows that  $\bigcup_i C_i^o$  consists of C-slow entrance points for  $s = 1$ .  $\square$

## References

- [1] L. Arnold, C. Jones, K. Mischaikow, G. Raugel, *Dynamical Systems Montecatini Terme 1994*, R. Johnson, ed., Lect. Notes Math. 1609, Springer-Verlag, 1995.
- [2] R. C. Churchill, Isolated invariant sets in compact metric spaces, *J. Diff. Eqs.* **12**, 330–352 (1972).
- [3] C. Conley, *Isolated Invariant Sets and the Morse Index*, CBMS Reg. Conf. Ser. in Math., 38, AMS, Providence, 1978.
- [4] C. Conley, A qualitative singular perturbation theorem, *Global Theory of Dynamical Systems*, Z. Nitecki and C. Robinson, eds., Lect. Notes Math. 819, Springer-Verlag, 1980, 65–89.
- [5] C. Conley and P. Fife, Critical manifolds, travelling waves, and an example from population genetics, *J. Math. Biology* (1982), 14, 159–176.
- [6] N. Fenichel, Geometric singular perturbation theory for ordinary differential equations, *J. Diff. Eqs.* **31** (1979), 53–98.
- [7] A. Floer, A refinement of the Conley index and an application to the stability of hyperbolic invariant sets, *Erg. Thy. & Dyn. Sys.* **7** (1987), 93–103.
- [8] R. Gardner and J. Smoller, The existence of periodic travelling waves for singularly perturbed predator-prey equations via the Conley index, *J. Diff. Eqs.* **47** (1983), 133–161.
- [9] T. Gedeon, H. Kokubu, K. Mischaikow, H. Oka, and J. Reineck, The Conley index for fast-slow systems I: One-dimensional slow variable, *J. Dynamics & Diff. Eqs.*, **11** (1999), 427–470.
- [10] M. Gameiro, T. Gedeon, W. Kalies, H. Kokubu, K. Mischaikow, and H. Oka, Topological horseshoes of traveling waves for a fast-slow predator-prey system, preprint, 2005.
- [11] C.K.R.T Jones and N. Kopell, Tracking invariant manifolds with differential forms in singularly perturbed systems, *J. Diff. Eqs.* **108** (1994), 64–88.
- [12] C. McCord and K. Mischaikow, Connected simple systems, transition matrices and heteroclinic bifurcations, *Trans. AMS* **333** (1992), 397–422.

- [13] C. McCord and K. Mischaikow, Equivalence of topological and singular transition matrices in the Conley index, *Mich. Math. J.* **42** (1995), 387–414.
- [14] C. McCord, K. Mischaikow, and M. Mrozek, Zeta functions, periodic trajectories, and the Conley index, *J. Diff. Eqs.* **121** (1995), 258–292.
- [15] K. Mischaikow, and M. Mrozek, Conley index, *Handbook of dynamical systems, Vol. 2*, p. 393–460, North-Holland, Amsterdam, 2002
- [16] K. Mischaikow, M. Mrozek and J. Reineck, Singular index pairs, *J. Dynamics & Diff. Eqs.*, **11** (1999), 399–425.
- [17] J. Rinzel, Models in neurobiology, *Nonlinear phenomena in physics and biology* (Eds. R.H. Enns, B.L. Jones, R.M. Miura and S.S. Rangnekar), pp. 345–367, Plenum, New York, 1981.
- [18] J. Rinzel and B. Ermentrout, Analysis of neural excitability and oscillations, *Methods in Neuronal Modeling: from Synapses to modeling* (Eds. Ch. Koch and I. Segev), MIT Press, 1991.
- [19] D. Salamon, Connected simple systems and the Conley index of isolated invariant sets, *Trans. AMS* **291** (1985), 1–41.
- [20] E. Spanier, *Algebraic Topology*, McGraw Hill, 1966; Springer-Verlag, New York, 1982.