

Oscillations in multi-stable monotone systems with slowly varying feedback

Tomáš Gedeon *

Department of Mathematical Sciences
Montana State University, Bozeman, MT
gedeon@math.montana.edu

and

Eduardo D. Sontag †
Department of Mathematics
Rutgers University, New Brunswick, NJ

November 30, 2006

Abstract

The study of dynamics of gene regulatory networks is of increasing interest in systems biology. A useful approach to the study of these complex systems is to view them as decomposed into feedback loops around open loop monotone systems. Key features of the dynamics of the original system are then deduced from the input-output characteristics of the open loop system and the sign of the feedback. This paper extends these results, showing how to use the same framework of input-output systems in order to prove existence of oscillations, if the slowly varying strength of the feedback depends on the state of the system.

1 Introduction

One of the most important challenges facing biologists and mathematicians in the postgenomic era is to understand how the behaviors of the cells arise from properties of complex signalling networks of proteins.

Networks that support bistable ([27, 29, 18, 6, 7, 30, 28]) and periodic ([14]) behaviors have attracted much attention in recent years. Bistable systems are thought to be involved in the generation of a switch-like biochemical responses ([18, 6]) as well as establishment of cell cycle oscillations and mutually exclusive cell cycle phases ([30, 28]).

*This research partially supported by grants NSF EIA-BITS-42611, NIH-NCRR P20 RR16455-04 and DMS/NIH-4W0467.

†This research partially supported by grants NSF DMS-0614371 and NSF DMS-0504557

In the recent work [2], Angeli and the second author developed a method that allows the detection of bistability in certain networks with feedback by studying the properties of the open loop system. The theory applies to systems that can be represented as a positive feedback loop around a monotone system with well-defined steady-state responses to constant inputs. The follow-up paper [5] described how this approach can be fruitfully applied in interesting biological situations, and [15] developed extensions of the basic framework. In principle, this approach applies to networks of arbitrary complexity. See [33] for a survey-level discussion of the topic.

Biologically, relaxation oscillators appear to underlie many important cell processes, such as the early embryonic cell cycle in frog eggs (*Xenopus* oocytes), cf. [30, 28]. Mathematically, a typical way in which relaxation (or “hysteresis-driven”) oscillators arise is through the interplay of a slowly acting parameter adaptation law and the dynamics of a bistable system. Let us briefly review the (well-known) intuitive picture.

Suppose that a certain one-dimensional system $\dot{x} = f_\lambda(x)$ has a bifurcation diagram that looks like the curve shown in Figure 1, where the horizontal axis indicates the parameter λ , with solid arrows showing, for each value of the parameter, in which direction the state x will move. Note the bistable region in the middle range of parameter space, where two stable (and one unstable) states x exist for each parameter value, such as for instance for $\lambda = q$.

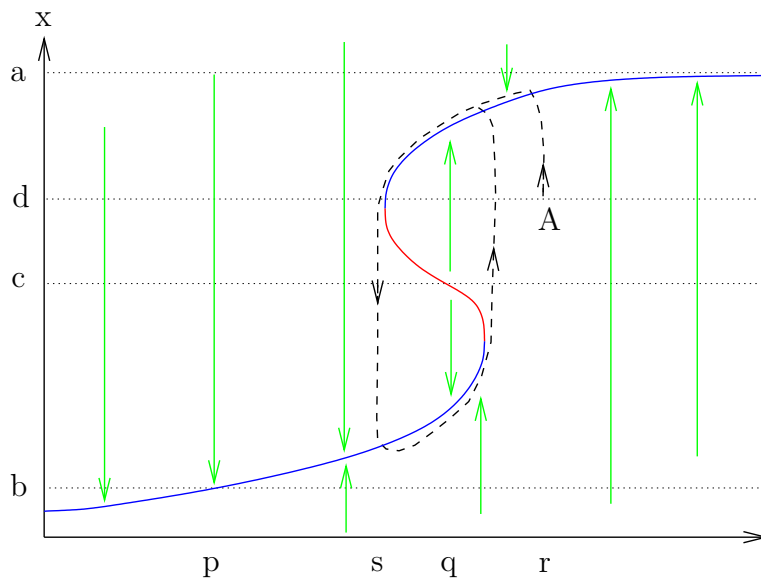

Figure 1: Relaxation from bistability

For example, still referring to Figure 1, if the parameter value is $\lambda = p$, the point $x = a$ will converge towards $x = b$ as the time $t \rightarrow \infty$; when the parameter is $\lambda = q$, the point $x = c$ is unstable; and so forth. Now suppose that the parameter itself is a function of the state x , with the “negative feedback” rule that the parameter will *slowly* decrease when x is larger than $x = c$ but will slowly increase when $x < c$. Let’s now analyze, for this feedback situation, what happens when the initial state is $x = d$ and the initial parameter

is $\lambda = r$ (point labelled “A” in the (λ, x) plane). The state x will move toward the positive direction, approaching an equilibrium (dashed curve). However, the parameter will slowly decrease, so that the equilibrium being approached keeps decreasing. In effect, the trajectory in the (λ, x) plane will tend to follow the bifurcation curve, until a point at which there are no stable equilibria nearby (parameter value “s”), A fast transition will occur towards the bottom branch. Now the state is less than c , so the feedback rule forces the parameter to increase, rather than decrease. There results an oscillation as shown by the dashed curve. For systems in dimension 1, a rigorous proof that a periodic orbit indeed exists for the joint (λ, x) dynamics can be based upon phase-plane techniques via the Poincaré-Bendixon Theorem, or using singular perturbation tools.

In essence, the techniques from [2] allow one to analyze the dynamics of $\dot{x} = f_\lambda(x)$, for states x of arbitrary dimension, using phase-plane-like techniques, where instead of the (λ, x) plane of Figure 1 one uses the (λ, u) space, and u is an “input” associated to the full system. In the case when u is scalar, the (λ, u) space is a plane and the the analysis required is as simple as for Figure 1. Bifurcation diagrams such as the one shown in Figure 1 are used to predict the behavior of the whole system.

This suggests that a slow feedback adaptation, acting entirely analogously to the description for one-dimensional systems, should again result in periodic orbits in this far more general situation. This fact would represent another instance of the principle that monotone input/output systems, as components of larger systems, behave in some sense like one-dimensional subsystems. The purpose of this paper is to provide a proof of this fact. Our proof is based upon a combination of i/o monotone systems theory and Conley Index theory. We also illustrate our results with the analysis of a model of the mitogen-activated protein kinase (MAPK) cascade in eukaryotic cells [18, 6, 7, 5]. We show that if the strength of the feedback from p42 MAPK to Mos depends on the state of the system, then the cascade is able to exhibit periodic behavior.

We observe that a totally different mechanism for the emergence of oscillations in feedback loops around monotone systems arises from *negative* feedback. There is by now a rich set of results characterizing conditions for *non*-oscillation in such negative feedback loops, see e.g. [1, 16, 13, 17]. When these conditions fail, there often result oscillations, at least if delays are inserted in the feedback loop ([3]). This other mechanism is closely related to Hopf bifurcations, in contrast to the relaxation oscillation framework studied in the present paper.

2 Preliminaries

We consider a finite-dimensional controlled system

$$\dot{x} = f(x, u), \quad y = h(x) \tag{1}$$

where $u(t) \in U \subseteq \mathbf{R}^m$ is the input, $y(t) \in Y \subseteq \mathbf{R}^m$ is the output, f, h are at least C^2 , and the state space variable $x(t) \in X \subseteq \mathbf{R}^n$. We assume that U, Y, X lie in the closure of their interiors. We assume that the input space and the output space have the same dimension, because we will investigate also a *closed loop system*, where, in addition to (1), we set

$$u = \lambda y. \tag{2}$$

Here λ is a scalar parameter, where in case $n > 1$, λ is understood to be a matrix λI . In order for (2) to be well defined we assume that $\lambda \in L$ a real interval and that $\bigcup_{\lambda \in L} \lambda Y \subset U$.

Our main motivation is the study of gene regulatory networks [5, 8], where often systems of the form (1),(2) have an additional structure of *monotone systems*. We now recall necessary definitions and for more background we refer the reader to [1, 31].

A *cone* is a closed, convex set with nonempty interior and with $\alpha K \subset K$ for $\alpha \in \mathbf{R}^+$ and $K \cap (-K) = \{0\}$. If a space Z is endowed with a cone K_z we will write

$$x \succeq y \text{ if, and only if, } x - y \in K_z \quad \text{and} \quad x \succ y \text{ if, and only if, } x - y \in \text{int}K_z.$$

We assume that the input space U , the state space X and the output space Y each has a distinguished cone $K_u \in U$, $K_x \in X$ and $K_y \in Y$.

We say that the controlled dynamical system (1) is a *monotone system with outputs* if the following two implications hold

$$\begin{aligned} u_1(t) \succeq u_2(t) \forall t, x_1 \succeq x_2 &\implies \varphi(t, x_1, u_1) \succeq \varphi(t, x_2, u_2) \\ x_1 \succeq x_2 &\implies h(x_1) \succeq h(x_2) \end{aligned}$$

where φ is the flow generated by (1), and the \succeq is with respect to appropriate cones. We say that the controlled dynamical system is *strongly monotone* if it is monotone and

$$u_1(t) \succeq u_2(t) \forall t, x_1 \succeq x_2 \implies \varphi(t, x_1, u_1) \succ \varphi(t, x_2, u_2)$$

Infinitesimal characterizations of monotonicity, which are more suitable for verification, can be found in [1] and [31]. We say that two points $x, y \in Z$ are *order related* if either $x \succ y$ or $y \succ x$ with respect to cone K_z .

The most important set of questions in this context concerns the predictability of the closed loop dynamics

$$\dot{x} = f(x, \lambda h(x))$$

based on the properties of the open loop system (1),(2).

Definition 2.1 We say that the controlled dynamical system (1) is endowed with *input-state characteristic* $k_x(u) : U \rightarrow X$ if for each constant input $u(t) \equiv \bar{u}$ there exists a (necessary unique) globally asymptotically stable equilibrium $k_x(\bar{u})$ of system (1). We also define the *input-output characteristic* as

$$k(u) := h(k_x(u)), \quad k : U \rightarrow U.$$

Lemma 2.2 [1, Proposition V.5] *The input-state characteristic $k_x(u)$ is a continuous function, which is monotone i.e $u \succeq_{K_u} v$ implies $k_x(u) \succeq_{K_x} k_x(v)$.*

3 Statement of the main result

The goal of this paper is to prove the existence of a periodic orbit in a closed loop system with a variable feedback strength

$$\begin{aligned}\dot{x} &= f(x, \lambda h(x)), \\ \dot{\lambda} &= -\epsilon q(x, \lambda)\end{aligned}\tag{3}$$

where $q(x, \lambda) : \mathbf{R}^n \times \mathbf{R} \rightarrow \mathbf{R}$ is a suitable function that will be specified later. The function $q(x, \lambda)$ can always be constructed so that $q(x, 0) = 0$ which implies $\lambda(t) \geq 0$ for all $t > 0$ if $\lambda(0) \geq 0$. This is often desirable in biological applications.

The system (3) has two time scales. Setting $\epsilon = 0$ we obtain a fast subsystem

$$\dot{x} = f(x, \lambda h(x))\tag{4}$$

where λ is a parameter. We will explore the correspondence between dynamics of the parameterized system (4) and the parameterized system

$$\dot{u} = k(u) - \frac{1}{\lambda}u.\tag{5}$$

We are ready to state our main Theorem. Our approach is especially useful when $m \ll n$ and thus the dimension of the input and the output space are much smaller than that of the state space X . Thus the dimensionality of the system (5) is much smaller than that of (4). Therefore we impose all technical assumptions of the next Theorem 3.1 on system (5), but the conclusions are drawn about the system (3). In the applications to gene regulation, the input-output function $k(u)$, as well as the strength λ of the feedback, are often experimentally accessible and controllable.

Theorem 3.1 *Assume that the system (1) is monotone and is endowed with an input-state characteristic $k_x(u)$. Further assume that*

- *for all λ the system (4) is strongly monotone and its solutions are bounded;*
- *there are values $0 < \lambda_{min} < \lambda_1 < \lambda_2 < \lambda_{max}$ in L such that (5) has one stable equilibrium for $\lambda = \lambda_{min}$, two stable and one unstable equilibrium for $\lambda \in (\lambda_1, \lambda_2)$ and one stable equilibrium for $\lambda = \lambda_{max}$;*
- *for each $\lambda \in [\lambda_{min}, \lambda_{max}]$ these equilibria are order-related with respect to the cone K_u ;*
- *the set of equilibria is connected.*

Then, for a generic function f , there is a function $q(x, \lambda)$ with $q(x, 0) = 0$, and an ϵ_0 , such that for all ϵ with $0 < \epsilon \leq \epsilon_0$ there is a periodic orbit of the system (3).

If, in addition, the control is scalar ($m = 1$) then the function $q(x, \lambda)$ can be constructed as

$$q(x, \lambda) = \lambda(h(x) - h(x_0)) = u - u_0.$$

where (λ_0, u_0) an unstable equilibrium of (5) and $x_0 = k_x(u_0)$.

Remark 3.2 Notice that the Theorem is not necessarily true for *all* nonlinearities f , but only for an open and dense subset of C^2 functions $\mathbf{R}^{n+m} \rightarrow \mathbf{R}^n$ in the compact-open topology. In fact, we need the following generic properties in the proof:

1. the input-state characteristic k_x is not constant on any open set in \mathbf{R}^m ;
2. the limit-point bifurcations of equilibria in the fast subsystem (4) with the bifurcation parameter λ are generic;
3. homoclinic orbits, if they exist, are isolated;
4. solutions of (4) with $\lambda = \lambda_1$ and $\lambda = \lambda_2$ on the unstable manifold of the semi-stable equilibrium at the limit-point bifurcation converge to the set of equilibria. Recall that by [31, Theorem 4.3] in a strongly monotone system for a generic $x \in \mathbf{R}^n$, $\omega(x)$ is contained in the set of equilibria. Therefore this assumption is generic in the class of functions satisfying assumption 1 of Theorem 3.1.

Remark 3.3 We will show below that the assumptions of Theorem 3.1 imply that there is an S-shaped set of equilibria of (5) in $U \times \mathbf{R}$. We will call the two branches that contain stable equilibria upper V_{top} and lower branch V_{bot} . The assumption that the equilibria are order related is used to show that there are corresponding disjoint equilibria branches of (4) in $X \times \mathbf{R}$. Since the branches are disjoint, we construct the function $q(x, \lambda) : X \times \mathbf{R}$ in such a way that the upper branch of equilibria belongs to the set where $q(x, \lambda) > 0$ and the lower branch of equilibria to the set where $q(x, \lambda) < 0$.

We now outline the proof of the main result. In section 4 we describe what the assumptions of Theorem 3.1 imposed on the system (5) imply for the system (4). In section 5 we formulate a simple two dimensional model which exhibits bistability and an S-shaped curve of equilibria. Using geometrical techniques we show that such system admits a positively invariant set in the shape of an annulus. Existence of such set together with a Poincaré section implies existence of a periodic orbit in the model problem in \mathbf{R}^2 . There is generalization of this result to higher dimensional spaces, based on the Conley index theory, due to McCord *et. al.* [26]. We verify the assumption of this result in a couple of steps. As the first step we identify a local 2-dimensional manifold in the neighborhood of the equilibria of the system (4) which can be mapped diffeomorphically to a neighborhood of the set of equilibria of the model problem. This map respects the direction of the flow.

The inverse image by this map takes the annular neighborhood of the equilibria of the model problem to a set, which can be extended to a neighborhood of the equilibria of (4). We show that, for all ϵ small enough, this neighborhood is an isolating neighborhood for system (3) and compute its Conley index. After verifying that the neighborhood admits a Poincaré section, we conclude that there is a periodic orbit in the neighborhood for all sufficiently small ϵ .

4 Correspondence between (5) and (4)

Definition 4.1 A vector field $\dot{u} = \phi(\lambda, u)$, where $\phi : \mathbf{R} \times \mathbf{R} \rightarrow \mathbf{R}$, undergoes a *generic limit point bifurcation* at (λ^*, u^*) when

$$\phi(\lambda^*, u^*) = 0 \quad , \quad \frac{d\phi}{du}(\lambda^*, u^*) = 0, \quad \phi_{uu} \neq 0 \quad \text{and} \quad \phi_\lambda \neq 0.$$

Definition 4.2 A limit point bifurcation of vector fields in \mathbf{R}^n , generated by $\dot{u} = g(\lambda, u)$, is generic, if the Lyapunov-Schmidt reduction $\phi(\lambda, u)$ to the one-dimensional kernel of $dg_u(\lambda^*, u^*)$ satisfies Definition 4.1.

Lemma 4.3 *Assume all assumptions of Theorem 3.1.*

1. *If the pair $(\lambda^*, u^*) \in \Lambda \times \mathbf{R}^m$ is an equilibrium of (5) then $(\lambda^*, k_x(u^*)) \in \Lambda \times \mathbf{R}^n$ is an equilibrium (4). On the other hand, if $(\lambda^*, x^*) \in \Lambda \times \mathbf{R}^n$ is an equilibrium (4) then there exists u^* such that $x^* = k_x(u^*)$ and (λ^*, u^*) is an equilibrium of (5).*
2. *The system (5) undergoes a limit point bifurcation at $\lambda = \lambda^*$, if and only if, (4) undergoes a limit point bifurcation at the same value of $\lambda = \lambda^*$.*

Proof. **1.** The equilibria of (4) satisfy the equation $f(x^*, \lambda^* h(x^*)) = 0$. This means that if we apply the constant input

$$u^* := \lambda^* h(x^*), \quad (6)$$

then the system (1) converges to the equilibrium x^* . By the definition of the function k_x this means that $x^* = k_x(u^*)$. Inserting the last expression into (6) we get $u^* = \lambda h(k_x(u^*)) = \lambda k(u^*)$, which implies that u^* is an equilibrium of (5). This shows that if (λ^*, x^*) is an equilibrium of (4) then there exists u^* with $x^* = k_x(u^*)$ and (λ^*, u^*) is an equilibrium of (5).

Now we assume that (λ^*, u^*) is an equilibrium of (5). Then $u^* = \lambda h(k_x(u^*))$ by the definition of the function k . Set $x^* := k_x(u^*)$. By definition of the I/S function k_x we have $f(k_x(u), u) \equiv 0$ and so $f(k_x(u^*), u^*) = 0$. Taking into account the definition of x^* , this equation can be rewritten as $f(x^*, \lambda h(x^*)) = 0$. This shows that $(\lambda^*, k_x(u^*))$ is an equilibrium of (4).

2. The normal form of the limit point bifurcation [19, Proposition 9.1] that we can parameterize the equilibrium set $f(x^*, \lambda^* h(x^*)) = 0$ of (4) in a neighborhood of a limit point bifurcation by a C^2 function $(0, 1) \rightarrow \Lambda \times \mathbf{R}^{n+m}$, $t \rightarrow (\lambda^*(t), x^*(t))$. Since k_x is continuous by Lemma 2.2, it follows from **1.** of this Lemma that there is a corresponding parameterization $t \rightarrow (\lambda^*(t), u^*(t))$ of equilibria of (5) such that the equilibria of (4) are then parameterized by the induced parametrization $t \rightarrow (\lambda^*(t), k_x(u^*(t)))$. The limit point bifurcation happens at a parameter value t^* that satisfies $\frac{d\lambda^*(t^*)}{dt} = 0$. Since this condition holds at the same value t^* for both parameterizations, the limit point bifurcations of (4) happens at the same values λ_1, λ_2 as limit point bifurcations of (5). \square

Set

$$g(\lambda, u) := k(u) - \frac{1}{\lambda}u. \quad (7)$$

It follows from the assumptions of Theorem 3.1 that g undergoes a limit point bifurcation at λ_1 and at λ_2 .

If (λ, u) is a regular zero of g , that is, $g(\lambda, u) = 0$ and $dg_u(\lambda, u)$ is nonsingular, then by the Implicit Function Theorem there is a C^2 function $u : (\lambda - \epsilon, \lambda + \epsilon) \rightarrow \mathbf{R}^m$ such that $g(\lambda, u(\lambda)) = 0$. It follows from the assumptions on genericity of f that the limit point bifurcation in the system (4) is generic at λ_1 . Therefore the equilibria of (4), and, as a consequence of Lemma 4.3.2, the zero set of $g(\lambda, u) = 0$ as well, can be parameterized by a C^2 function $(0, 1) \rightarrow [\lambda_1, \lambda_1 + \epsilon) \times \mathbf{R}^m$, $t \rightarrow (\lambda(t), u(t))$. A similar function exists in the

neighborhood $(\lambda_2 - \epsilon, \lambda_2] \times \mathbf{R}^m$ of the limit point bifurcation at λ_2 . Since the set of equilibria is connected we paste all local functions together to obtain a parameterization of the set of equilibria of (5) by a C^2 embedding

$$z : [0, 1] \rightarrow \Lambda \times \mathbf{R}^m \quad (8)$$

which maps $t \rightarrow (\lambda(t), u(t))$. There are two values $t_2 < t_1 \in [0, 1]$ that correspond to limit point bifurcations at λ_2 and λ_1 , respectively. That is, the lambda coordinate of $z(t_2)$ is λ_2 and of $z(t_1)$ is λ_1 . Let $V := z([0, 1])$, $V_{bot} := z([0, t_2])$, $V_{mid} := z([t_2, t_1])$ and $V_{top} := z([t_1, 1])$ be the equilibria branches of (5) in $\Lambda \times \mathbf{R}^m$.

Definition 4.4 We define sets

$$M_* := \{(\lambda, k_x(u)) \mid (\lambda, u) \in V_*\}$$

where $*$ = *mid, top, bot*. Observe that $M_* \subset \Lambda \times \mathbf{R}^n$.

It follows from Lemma 4.3.1 that the set M consists of equilibria of the system (4). Next, we address the stability of these equilibria.

Lemma 4.5 *Assume all assumptions of Theorem 3.1.*

1. *If $v \in \mathbf{R}^m$ spans the kernel of $Dg_u(\lambda^*, u^*)$ then $Dk_x v \in \mathbf{R}^n$ spans the kernel of Df_x at $(\lambda^*, k_x(u^*))$.*
2. *(λ^*, u^*) is a stable equilibrium of (5) if, and only if, $(\lambda^*, k_x(u^*))$ is a stable equilibrium (4).*
3. *If for every $\lambda \in \Lambda$ the equilibria of (5) are order related, then $M_{bot} \cap M_{top} = \emptyset$.*

Proof. 1. Along the curve $z(t)$ of equilibria of (5) we have

$$h(k_x(u(t))) - \frac{1}{\lambda(t)}u(t) \equiv 0$$

for all $t \in [0, 1]$ and by the chain rule

$$Dh(k_x(u(t))) \circ Dk_x \frac{du}{dt} + \frac{1}{\lambda^2(t)} \frac{d\lambda}{dt} u(t) - \frac{1}{\lambda(t)} \frac{du}{dt} \equiv 0. \quad (9)$$

At the limit point bifurcation (λ^*, u^*) we have $\frac{d\lambda}{dt}(\lambda^*, u^*) = 0$, from which we obtain

$$(Dh(k_x(u^*)) \circ Dk_x(u^*) - \frac{1}{\lambda(t)}I) \frac{du}{dt} = 0. \quad (10)$$

Since (compare (7))

$$Dg_u(\lambda^*, u^*) = Dh(k_x(u^*)) \circ Dk_x(u^*) - \frac{1}{\lambda(t)}I$$

we see that the vector

$$v := \frac{du}{dt}$$

is a zero eigenvector of $Dg_u(\lambda^*, u^*)$. By assumption this is the unique zero eigenvector of $Dg_u(\lambda^*, u^*)$.

Now we analyze the system (4). The equilibria of (4) satisfy the identity

$$f(x(t), \lambda h(x(t))) \equiv 0.$$

We differentiate to obtain

$$Df_x \frac{dx}{dt} = Df_1 \frac{dx}{dt} + (Df_2) \left(\frac{d\lambda}{dt} h(x(t)) + \lambda \frac{dh}{dx} \frac{dx}{dt} \right) \equiv 0, \quad (11)$$

where Df_i , $i = 1, 2$ denotes the derivative of f with respect to the i -th argument. At the bifurcation point $\frac{d\lambda}{dt} = 0$ and we get

$$Df_x \frac{dx}{dt} = [Df_1 + Df_2 \lambda \frac{dh}{dx}] \frac{dx}{dt} = 0.$$

Since $x(t) = k_x(u(t))$ along the set of equilibria, the null vector at the bifurcation is

$$\frac{dx}{dt} = Dk_x \frac{du}{dt} = Dk_x v.$$

Therefore $Dk_x v$ spans the kernel of Df_x at $(\lambda^*, k_x(u^*))$.

2. This is the result [15, Theorem 2].

3. Assume that $M_{top} \cap M_{bot} \neq \emptyset$. By the definition of branches M_{bot} and M_{top} this means there are equilibria $(\lambda_1, u_1) \in U_{bot}$ and $(\lambda_2, u_2) \in U_{top}$ of (5) such that $(\lambda_1, k_x(u_1)) = (\lambda_2, k_x(u_2))$. This implies $\lambda_1 = \lambda_2$ and $k_x(u_1) = k_x(u_2)$. Since k_x is monotone by Lemma 2.2, we must have $k_x(u_1) = k_x(u) = k_x(u_2)$ for any constant input u satisfying $u_1 \succ u \succ u_2$. By the assumption the equilibria u_1 and u_2 at the parameter value λ are order related, let us say $u_1 \succ u_2$ and $u_1 \neq u_2$. Therefore the set of such u contains an open set in \mathbf{R}^m . This is a contradiction with the assumption that k_x is not constant on open sets, see Remark 3.2. \square

We summarize the results of this section in a Proposition.

Proposition 4.6 *Assume all assumptions of Theorem 3.1. Then there is an S-shaped curve of equilibria $M = M_{bot} \cup M_{mid} \cup M_{top}$ in $\Lambda \times \mathbf{R}^n$ and a function $q(x, \lambda) : \mathbf{R}^n \times \Lambda \rightarrow \mathbf{R}$ such that*

1. at $\lambda_1, \lambda_2 \in \Lambda$ a generic limit point bifurcations take place;
2. the relative interior of M_{top} and M_{bot} consist of stable equilibria of (4);
3. $q(x, \lambda) > 0$ on M_{top} , $q(x, \lambda) < 0$ on M_{bot} and the set

$$\mathcal{G} := \{(x, \lambda) \in \mathbf{R}^n \times \Lambda \mid q(x, \lambda) = 0\}$$

has a distance from $M_{bot} \cup M_{top}$ bounded away from 0;

$$4. \quad q(x, 0) = 0.$$

Proof. By the discussion after Lemma 4.3 there is an S -shaped curve of equilibria of the system (5) in $\Lambda \times \mathbf{R}^m$ and the bifurcations at λ_1, λ_2 are generic limit point bifurcations. By the definition of the set M and Lemma 4.3.1, M consists of equilibria of (4) and by Lemma 4.3.2 and 4.5.1 there are generic limit point bifurcations at λ_1, λ_2 . By Lemma 4.5.2 the relative interior of M_{top} and M_{bot} consists of stable equilibria of (4) since by assumption the relative interior of V_{top} and V_{bot} consists of stable equilibria of (5).

Since by Lemma 4.5.3 $M_{bot} \cap M_{top} = \emptyset$ there exists a separating n dimensional manifold $\mathcal{G} \subset \mathbf{R}^n \times \Lambda$ that is given by $q(x, \lambda) = 0$ for some real-valued function q . Without loss of generality we may assume that $q(x, \lambda) > 0$ on M_{top} and $q(x, \lambda) < 0$ on M_{bot} . Since \mathcal{G} is closed, the distance from \mathcal{G} to either M_{top} or M_{bot} is bounded below by a nonzero constant. Finally, we may select function q with additional property that $q(x, 0) = 0$ in order for λ in the equation (3) to remain positive. Since all the equilibria satisfy $\lambda > 0$, we can guarantee such property by modifying the function q locally in the neighborhood of $\lambda = 0$. \square

5 Planar problem

Define a model planar problem

$$\begin{aligned} \dot{y} &= \zeta - y(y^2 - 1) \\ \dot{\zeta} &= -\epsilon y. \end{aligned} \tag{12}$$

The fast subsystem is obtained by setting $\epsilon = 0$ in (12)

$$\begin{aligned} \dot{y} &= \zeta - y(y^2 - 1) =: \zeta - G(y) \\ \dot{\zeta} &= 0 \end{aligned} \tag{13}$$

with $\zeta \in [-1, 1]$. Let $S := \{(\zeta, y) \in \mathbf{R}^2 \mid \zeta = G(y)\}$. The set S has three branches S_{bot}, S_{mid} and S_{top} defined by $y < -1/\sqrt{3}$, by $1/\sqrt{3} > y > -1/\sqrt{3}$ and by $y > 1/\sqrt{3}$, respectively. We denote by Z a curve in \mathbf{R}^2 depicted in Figure 2.A, that consists of $S_{bot} \cup S_{top}$ and the two vertical connecting pieces.

We now recall a classical construction, where we follow Jones [22]. Similar constructions also appear in Lefschetz [23] and Hale [20].

Lemma 5.1 *For any $\delta > 0$ there exists an $\epsilon_0 > 0$ and an open set N , lying entirely within a distance δ of Z , that is positively invariant for (12).*

Proof. The construction is seen most easily with the aid of a picture, see Figure 2.B. We construct the boundary of the set N . Draw graphs of $\zeta = G(y) \pm h$; take a point A on the graph of $\zeta = g(y) - h$ just above (in y -coordinate) the left turning point of $\zeta = g(y) - h$, draw a line with positive slope to a point B on the horizontal axis, and then draw a vertical line to a graph $\zeta = G(y)$ at point C . This is followed by a horizontal line to a point D on graph of $\zeta = G(y) + h$ and then piece of graph of $\zeta = G(y) + h$ to a point E just below of the

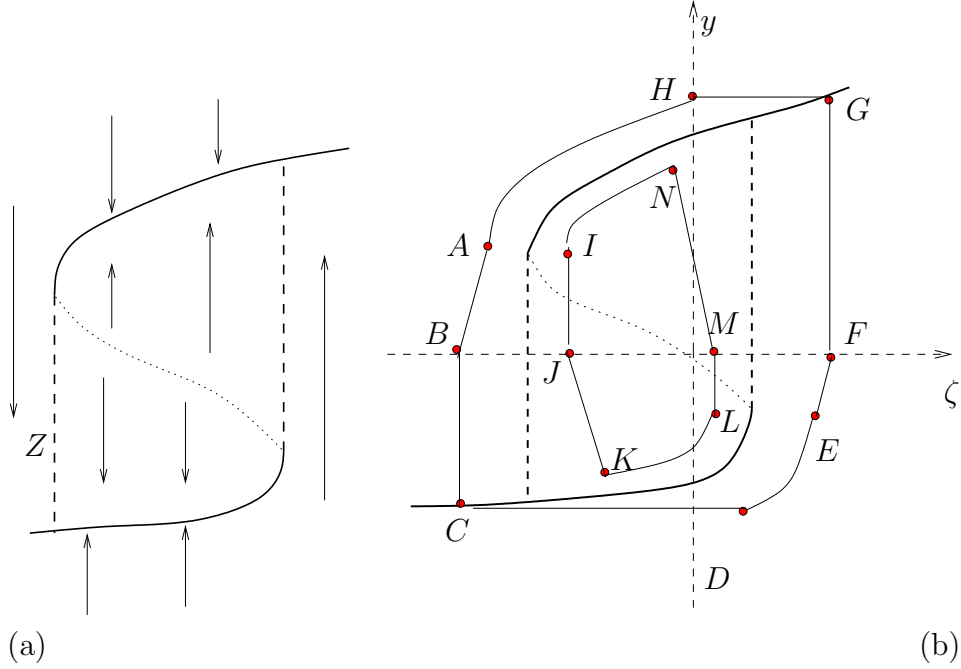

Figure 2: (a) The Z curve, (b) The set N in the neighborhood of the Z curve, that is positively invariant under the flow of (12)

right turning point of $\zeta = G(y) + h$. This point is symmetric to the point A and we finish the construction in a symmetric way by constructing points F, G and H . This finishes the outer boundary of N . The inner boundary consists of 2 pieces of graphs $\zeta = G(y) \pm h$, two vertical pieces and two pieces with negative slope, see Figure 2.B.

Now we show that the flow of (12) is pointing inward on the outer boundary of N . As a guidance we will use the vector field generated by (13); if it points inward on the boundary of N , so does the vector field of (12) for small ϵ . On the segment AB the slope is positive and vector field of (13) is vertical and pointing down so it points in on AB . Analogous reasoning applies for segments CD and DE , using the fact that the slope is positive on DE , since E is below the right turning point of $\zeta = G(y) + h$. By symmetry, the vector field points in on EF, GH and HA . The argument for BC and FG cannot be made using (13), since these lines are vertical. However, the second equation in (12) causes the vector field to point right along BC and left along FG , as desired.

Analogous arguments can be used for the inner boundary and by choosing h sufficiently small, we can make N to be in a δ neighborhood of Z for any $\delta > 0$. \square

6 Correspondence between (13) and (4)

The essential step in description of the correspondence between (13) and (4) is to define special coordinates in the neighborhood of the set of equilibria M . We start by using the

Lyapunov-Schmidt reduction ([19]) at the limit point bifurcation (λ_1, x_1) . Since the limit point bifurcation at λ_1 is generic, by [19, Proposition 9.1] in the neighborhood U_1 of the point (λ_1, x_1) there are local coordinates $(\lambda, v_1, v_2) \in \mathbf{R} \times \mathbf{R} \times \mathbf{R}^{n-1}$ in which the flow of (4) has the form

$$\begin{aligned}\dot{v}_1 &= (\lambda - \lambda_1) - v_1^2 \\ \dot{v}_2 &= A_1(\lambda)(v_1, v_2)^T + h_1(\lambda, v_1, v_2)\end{aligned}$$

where $h_1(\lambda, v) = O(\|v\|^2)$ as $\|v\| \rightarrow 0$. Since we assume that M_{bot} consists of stable points, all eigenvalues of $A_1(\lambda)$ are negative and bounded away from zero.

Similarly, near (λ_2, x_2) there are local coordinates $(\lambda, w_1, w_2) \in \mathbf{R} \times \mathbf{R} \times \mathbf{R}^{n-1}$ in a neighborhood U_2 of (λ_2, x_2) in which the flow of (4) has the form

$$\begin{aligned}\dot{w}_1 &= (\lambda_2 - \lambda) - w_1^2 \\ \dot{w}_2 &= A_2(\lambda)(w_1, w_2)^T + h_2(\lambda, w_1, w_2),\end{aligned}\tag{14}$$

with h_2 and A_2 having the same properties as h_1 and A_1 respectively. By taking U_1 and U_2 smaller, if necessary, we can assure that $U_i \cap \mathcal{G} = \emptyset$ for $i = 1, 2$.

Now we prove a global result which uses in an essential way the fact that for each fixed λ the system (4) is monotone.

Lemma 6.1 *Assume all assumptions of Theorem 3.1. Take x in the branch of the unstable manifold of a point $w \in M_{mid} \cap U_2$ that leaves U_2 in finite time. Then $\omega(x) \subset M_{top}$. Similarly, for x in the branch of the unstable manifold of a point $w \in M_{mid} \cap U_1$ that leaves U_1 in finite time, we have $\omega(x) \subset M_{bot}$.*

Proof. We prove only the first part, since the proof of the second part is analogous. Let

$$\pi : \mathbf{R}^n \times \Lambda \rightarrow \Lambda$$

be the coordinate projection. The system (4) generates a parameterized flow ψ , that is, for each λ fixed, the flow preserves the λ -slice of the phase space. We denote the induced flow by ψ^λ . Let $(\mu, \lambda_2]$ be the set of all values of λ in $\Pi(U_2)$ smaller than λ_2 .

Take arbitrary $\lambda \in (\mu, \lambda_2]$. Then by (14) there are two equilibria w_{mid}^λ and w_{bot}^λ in U_2 ; the second being stable and the first one with one-dimensional unstable manifold. Further, one branch of the unstable manifold of w_{mid}^λ connects to w_{bot}^λ . We denote by Ξ^λ the other branch of $W^u(w_{mid}^\lambda)$. By the assumptions of Theorem 3.1 there exist three equilibria of ψ^λ ; the third one lies on M_{top} and we denote it by w_{top}^λ .

We now show that there is an interval $(\nu, \lambda_2] \subset (\mu, \lambda_2]$ such that for all $\lambda \in (\nu, \lambda_2]$ and all $x^\lambda \in \Xi^\lambda$, $\omega(x^\lambda) = w_{top}^\lambda$.

First, for a generic f (see Remark 3.2.4) and all $x^{\lambda_2} \in W^u(w_{mid}^{\lambda_2}) = \Xi^{\lambda_2}$ the omega-limit set $\omega(x^{\lambda_2})$ is contained in the set of equilibria. Further, by assumption the flow ψ^λ is strongly monotone. It follows from [31, Theorem 4.3] that for a generic $x \in \mathbf{R}^n$, $\omega(x)$ is contained in the set of equilibria. Therefore there is $\mu_1 < \lambda_2$ such that for all $\lambda \in (\mu_1, \lambda_2]$ and all $x^\lambda \in \Xi^\lambda$, $\omega(x^\lambda)$ is contained in the set of equilibria.

Since the bifurcation at $\lambda = \lambda_2$ is generic (see Remark 3.2.2), there is no homoclinic orbit to $w_{mid}^{\lambda_2}$. Further, for a generic f , (see Remark 3.2.3) the homoclinic orbits are isolated. Therefore there is an μ_2 with $\mu_1 \leq \mu_2 < \lambda_2$ such that for all $\lambda \in (\mu_2, \lambda_2]$ and any $x^\lambda \in \Xi^\lambda$, the omega-limit set $\omega(x^\lambda) \neq w_{mid}^\lambda$.

Finally, since by assumption all solutions of (4) are bounded, for all $\lambda \in (\mu_2, \lambda_2]$ and all $x^\lambda \in \Xi^\lambda$ either $\omega(x^\lambda) = w_{top}^\lambda$ or $\omega(x^\lambda) = w_{bot}^\lambda$. We first note that these conditions are open, that is, if $\omega(x^{\lambda_0}) = w_{top}^{\lambda_0}$, then for all λ with $|\lambda - \lambda_0|$ sufficiently small we have $\omega(x^\lambda) = w_{top}^\lambda$ for all $x \in \Xi^\lambda$. Therefore there is either a ν with $\mu_2 \leq \nu < \lambda_2$ such that for all $\lambda \in (\nu, \lambda_2]$ and all $x^\lambda \in \Xi^\lambda$ we have $\omega(x^\lambda) = w_{top}^\lambda$, or there is a sequence $\{\zeta_n\}_{n=1}^\infty \subset (\mu_2, \lambda_2]$ such that $\lim_{n \rightarrow \infty} \zeta_n = \lambda_2$ such that for all $x^{\zeta_n} \in \Xi^{\zeta_n}$, $\omega(x^{\zeta_n}) = w_{bot}^{\zeta_n}$.

We assume the second case and show that this leads to a contradiction. Observe that in the second case all solutions on both branches of $W^u(w_{mid}^{\zeta_n})$ converge to the point $w_{bot}^{\zeta_n}$, and this is true for all n . By continuity and by the fact that the bifurcation at λ_2 is generic, there exists a periodic orbit for $\lambda > \lambda_2$, with $\lambda - \lambda_2 \ll 1$. See Figure 3.

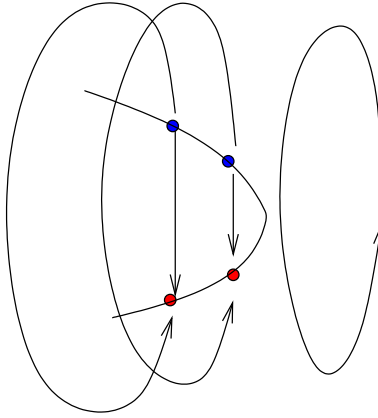

Figure 3: Limit point bifurcation gives rise to a stable periodic orbit

Again, since the bifurcation at λ_2 is generic limit point bifurcation and since the branch M_{bot} consists of stable equilibria, this periodic orbit must be stable for $\lambda > \lambda_2$, with $\lambda - \lambda_2 \ll 1$. This contradicts the fact that the stable periodic orbits do not exist in monotone dynamical systems [31, Theorem 4.3]. Therefore there is an interval $(\nu, \lambda_2]$ such that for all $\lambda \in (\nu, \lambda_2]$ and all $x^\lambda \in \Xi^\lambda$ $\omega(x^\lambda) = w_{top}^\lambda$. The result now follows if we choose U_2 satisfying $\pi(U_2) \subset (\nu, \infty)$. \square

Let

$$\mathcal{M} := M_{top} \cup M_{bot} \cup (M_{mid} \cap (U_1 \cup U_2)).$$

We extend the local coordinates defined around the bifurcation points to a neighborhood of \mathcal{M} .

Lemma 6.2 *There is a neighborhood U of \mathcal{M} with $U_1 \cup U_2 \subset U$ and coordinates $(\lambda, u, v) \in \mathbf{R} \times \mathbf{R} \times \mathbf{R}^{n-1}$ in U in which the flow has the form*

$$\dot{u} = h(\lambda, u)$$

$$\dot{v} = A(\lambda)(u, v)^T + H(\lambda, u, v)$$

such that

1. $u = v_1$ and $v = v_2$ in U_1 ;
2. $u = w_1$ and $v = w_2$ in U_2 ;
3. $H(\lambda, u, v) = O(\|(u, v)\|^2)$ as $\|(u, v)\| \rightarrow 0$.

Proof. We first review the information about the set of equilibria M . By Proposition 4.6 there are generic limit-point bifurcations at $\lambda_i, i = 1, 2$, the equilibria in the relative interior of $M_{bot} \cup M_{top}$ are stable. Since limit point bifurcations in U_1 and U_2 are generic, each equilibrium $w \in M_{mid} \cap (U_1 \cup U_2)$ has one-dimensional unstable manifold.

Now we extend coordinates $(w_1, w_2) \in U_2$ to a neighborhood of M_{bot} . Let A_w be the linearization of (4) at $w = M_{bot} \cap \pi^{-1}(\lambda)$. Then the map $x \rightarrow A_w x$ is monotone with respect to K_X ([2, Lemma 6.4]) and the matrix A_w admits a Perron-Frobenius eigenpair (μ_w, e_w) . Since the equilibrium w is stable, the eigenvalue $\mu_w \leq 0$. We would like to select a one dimensional stable manifold that is tangent to the eigenvector e_w which changes continuously with the base point w . Unfortunately, such manifold is not unique, as one can see from the following example in the plane. Consider the vector field

$$\dot{x}_1 = -x_1, \quad \dot{x}_2 = -2x_2.$$

In this example, the choice of two points, one in the left and one in the right half-plane determines unique manifold, that is tangent to x_1 axis in the origin. A result of Brunovsky [9] generalizes this observation. Let $\Sigma_1 = \{\mu_w\}$ and let Σ_2 contains the rest of the spectra of A_w . Assume for the moment that there is β, γ, μ such that $\lambda < \beta < \gamma < \mu_w < \mu < 0$ for all $\lambda \in \Sigma_2$. Let P_i be spectral projection corresponding to Σ_i , let $X_i = P_i X$ and $A_i = P_i A_w$. By the standard theory, there are local coordinates x_1, x_2 in the neighborhood of w such that

$$\gamma|x_1|^2 < \langle x_1, A_1 x_1 \rangle < \mu|x_1|^2, \quad \langle x_2, A_2 x_2 \rangle < \beta|x_2|^2.$$

For given η let $\Gamma_\eta := \{x_1 : |x_1| = \eta\}$ which in our case is a two point set, since $x_1 \in \mathbf{R}$. Then a result of Brunovsky [9] states, that for sufficiently small η and any function $\sigma : \Gamma_\eta \rightarrow X_2$, there is a unique manifold O_w , tangent to e_w , such that $graph(\sigma) \subset O_w$. In our case, the function σ has only two values, one for $x_1 = \eta$ and one for $x_1 = -\eta$.

An important observation is that the manifold changes continuously with the point $w \in M_{bot}$, if the function σ changes continuously.

We assumed in the above argument that μ_w is an isolated point of the spectra. If μ_w has higher multiplicity k , the set Σ_1 would have dimension k . Non-uniqueness is still present, but once we select a particular k -dimensional manifold tangent to the eigenspace corresponding to Σ_1 , this manifold is foliated by one dimensional sub-manifolds, since all eigenvalues in Σ_1 are identical. Thus we specify a continuous function σ to select a continuous set of k dimensional manifolds parameterized by the base point w , and then select one dimensional sub-manifolds in such a way that they change continuously as a function of $w \in M_{bot}$.

We will now select a particular one dimensional manifold for each $w \in M_{bot}$. By Lemma 6.1, if $\lambda \in U_1$ and $\lambda_1 < \lambda$ then one branch of the unstable manifold of w_{mid} at

this λ has to connect to w_{bot} . By continuity, all points (x, λ) on such a branch of W_{mid}^u , with $\lambda < \lambda_1$ and $\|x - x^*\| < \epsilon$ converge to M_{bot} and we can assume without loss that this is true for all $(x, \lambda) \in U_1$. We select the one dimensional manifolds along M_{bot} in such a way that they coincide with the unstable manifold $W^u(w_{mid})$ for all $w_{mid} \in M_{mid} \cap U_1$ and extend this choice continuously for $\lambda < \lambda_1$. We select variables u along these sub-manifolds and select v to be the complementary variables.

A similar construction allows the extension of the local coordinates v_1, v_2 from U_2 to a neighborhood of M_{top} . The result now follows. \square

Definition 6.3 Using the coordinates of Lemma 6.2, define a 2-dimensional manifold in the neighborhood U of \mathcal{M} (see Figure 4),

$$\mathcal{U} := \{(\lambda, u, v) \in U \mid v = 0\}.$$

Having defined local coordinates in neighborhood U of \mathcal{M} we relate them to local coordinates in the neighborhood of S . Recall that ψ denotes the parameterized flow of (4) and let φ denotes the parameterized flow of (13).

Define a mapping $F : \mathcal{U} \rightarrow \mathbf{R}^2$ in two stages. First, since (13) undergoes a generic limit point bifurcation at $\zeta = \pm 1/\sqrt{3}$ and the parameterization e of M is continuous, there exists a diffeomorphism F taking M to S in such a way that M_{top}, M_{bot} and M_{mid} map to S_{top}, S_{bot} and S_{mid} , respectively and $F(\mathcal{G} \cap M_{mid}) = (0, 0)$. Take an arbitrary $w_{top}^{\lambda_0} \in M_{top}$. Take B a neighborhood of λ_0 in (λ, ∞) and let $\mathcal{U}_B := \{(\lambda, u, v) \in U \mid \lambda \in B, v = 0\}$ be a 2-dimensional manifold, that is foliated by one-dimensional stable sub-manifolds $W^s(w_{top}^\lambda)$, $\lambda \in B$. There is also a neighborhood $\bar{U} \in \mathbf{R}^2$ of $F(w_{top}^{\lambda_0})$ that is foliated by the stable manifolds of points $F(w_{top}^\lambda)$, $\lambda \in B$. We extend F to \mathcal{U}_B in such a way that it maps flow lines of ψ on \mathcal{U}_B to flow lines of φ on \bar{U} and preserves the direction of the flow. By a similar argument we can define the map F on a neighborhood \mathcal{U}_B of an arbitrary point $w_{bot}^{\lambda_0}$.

If $w_{mid}^{\lambda_0} \in M_{mid} \cap U_1$ or $w_{mid}^{\lambda_0} \in M_{mid} \cap U_2$, then there is a 2-dimensional manifold \mathcal{U}_B , given by $v = 0$, such that $B := \Pi(\mathcal{U})$ is a neighborhood of λ_0 . The manifold \mathcal{U}_B is foliated by unstable manifolds $W^u(w_{mid}^\lambda)$ with $\lambda \in B$. There is also a neighborhood of $\bar{U} \in \mathbf{R}^2$ of $F(w_{mid}^{\lambda_0})$ that is foliated by unstable manifolds of points $F(w_{mid}^\lambda)$ with $\lambda \in \Pi(B)$. We can again extend F to \mathcal{U}_B in such a way that it maps flow lines of ψ on \mathcal{U}_B to flow lines of φ in \bar{U} and preserves direction of the flow.

Finally, since both systems undergo generic limit point bifurcations, the map F can be defined in the union $U_1 \cup U_2$.

Definition 6.4 ([24]) Two C^r flows φ on M and ψ on N are C^m orbit equivalent ($m \leq r$) if there is a C^m diffeomorphism $h : M \rightarrow N$ such that $\chi(t) = h \circ \psi(t) \circ h^{-1}$ is a time re-parameterization of the flow φ .

We summarize our construction in the following Lemma.

Lemma 6.5 *The flow ψ restricted to the \mathcal{U} , is orbit equivalent to the flow φ in the neighborhood of S , via the map F .*

By Lemma 6.1 the omega limit set of $x \in \mathcal{U} \cap U_1$ lies in M_{bot} and the omega limit set of $x \in \mathcal{U} \cap U_2$ lies in M_{top} .

We now show that the map F can be extended the set

$$\bigcup_{x \in U_2 \cup U_1} \bigcup_{t \geq 0} \psi(t, x).$$

By Lemma 6.5 there is a flow $\chi(t)$ on \mathbf{R}^2 defined by $\chi(t) = F \circ \varphi(t) \circ F^{-1}$ and an increasing function $\tau(t)$ such that

$$\varphi(\tau(t)) = \chi(t).$$

Fix $\lambda \in \pi(U_1)$, $\lambda > \lambda_1$. For such λ the flow ψ^λ has equilibria $w_{mid}^\lambda \in M_{mid}$, $w_{bot}^\lambda \in M_{bot}$ and one branch of the unstable manifold connects w_{mid}^λ to w_{bot}^λ . We denote this branch by $\bar{W}^u(w_{mid}^\lambda)$. Fix a point $x^\lambda \in \bar{W}^u(w_{mid}^\lambda) \cap U_1$ and observe that there are intervals $(-\infty, a^\lambda)$ and (b^λ, ∞) such that $\psi(t, x^\lambda) \in U$ for $t \in (-\infty, a^\lambda) \cup (b^\lambda, \infty)$. It is on these intervals that the function $\tau(t)$ is defined.

By the construction of the neighborhood U_1 we have $\mathcal{G} \cap U_1 = \emptyset$. Since $q(\alpha(x^\lambda), \lambda) < 0$ and $q(\omega(x^\lambda), \lambda) > 0$ for α - and ω - limit sets of x^λ , there is at least one time $T^\lambda \in [a^\lambda, b^\lambda]$ such that $\psi(T^\lambda, x^\lambda) \in \mathcal{G}$. By the flow box theorem the flow emanating from all such $x^\lambda \in \bar{W}^u(w_{mid}^\lambda)$ is parallelizable. Therefore, by changing the function q if necessary, we can assure that this time T^λ is in fact unique for every $x^\lambda \in \bar{W}^u(w_{mid}^\lambda)$, where $w_{mid}^\lambda \in M_{mid} \cap U_1$. Now we extend the function $\tau(t) = \tau(\lambda, t)$ continuously and monotonically to

$$(\pi(\Lambda) \cap \{\lambda > \lambda_1\}) \times [a^\lambda, b^\lambda]$$

in such a way that

$$F(\lambda, \psi(T^\lambda, x^\lambda)) = (\lambda, 0). \quad (15)$$

Finally, for a pair (λ, y) where $\lambda > \lambda_1$, $\lambda \in \pi(\Lambda)$ and $y = \psi^\lambda(t, x^\lambda)$ for some $t \in [a^\lambda, b^\lambda]$ we define

$$F(\lambda, y) := \varphi(\tau(t), F(\lambda, \psi^\lambda(-t, y))).$$

Since we renormalized the time in the interval $[a^\lambda, b^\lambda]$, this map is well defined. A similar extension can be done for $\lambda \in \pi(U_2)$, $\lambda < \lambda_2$ and $x^\lambda \in W^u(M_{mid})$. The choice (15) implies that the map F maps points lying on \mathcal{G} into the line $y = 0$ in \mathbf{R}^2 .

Now we consider $\lambda \in \pi(U_1)$, $\lambda < \lambda_1$. By making the neighborhood U_1 smaller, if necessary, we can assure that for (λ, x^λ) such that $x^\lambda \in \mathcal{U} \cap U_1$ and $\lambda < \lambda_1$, $\omega(x^\lambda) \in M_{bot}$. This follows by continuity on initial conditions and the fact that M_{bot} consists of stable equilibria. The analogous construction to the one above allows an extension of F to all trajectories starting at such pairs (λ, x^λ) ; this obviously also holds in the neighborhood U_2 of the other turning point.

We call the resulting map, defined on

$$\mathcal{H} := \mathcal{U} \cup \bigcup_{x \in U_2 \cup U_1} \bigcup_{t \geq 0} \psi(t, x),$$

again F . Observe that the range F contains a neighborhood of the curve Z in Figure 2.

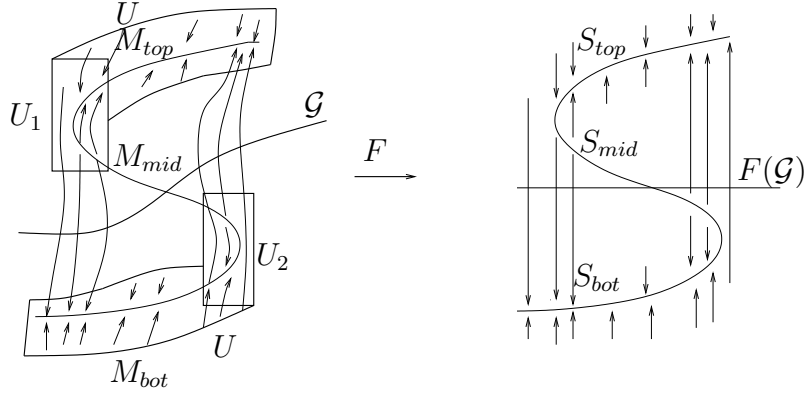

Figure 4: Map F maps the 2-dimensional manifold in the neighborhood of the set M to its image in \mathbf{R}^2 . The flow ψ (left figure), generated by (4), is orbit equivalent to the flow φ (right figure), generated by (13). The neighborhoods U_1 and U_2 of the turning points on M are also indicated.

6.1 Lifting of the planar problem.

Let ψ_ϵ denotes the flow of (3) and let φ_ϵ denotes the flow of (12).

A set \mathcal{N} is an *isolating neighborhood* if $\text{Inv } \mathcal{N} \subset \text{int } \mathcal{N}$; that is, if the maximal invariant set S in N lies in the interior of \mathcal{N} .

An isolating neighborhood N is an *isolating block* if $\partial N = N^+ \cup N^-$, where N^- is the *immediate exit set* and N^+ is the *immediate entrance set*

$$\begin{aligned} N^- &:= \{x \in N \mid \varphi([0, t], x) \not\subset N \text{ for all } t > 0\} \\ N^+ &:= \{x \in N \mid \varphi([t, 0], x) \not\subset N \text{ for all } t < 0\}; \end{aligned}$$

and both N^+ and N^- are subsets of local sections of the flow.

Lemma 6.6 *Let $N' := F^{-1}(N) \subset \mathcal{H}$, where $N \subset \mathbf{R}^2$ is the neighborhood of the Z-curve constructed in Lemma 5.1.*

Then there is an neighborhood \mathcal{N} of N' in $\Lambda \times \mathbf{R}^n$ and ϵ_0 , such that \mathcal{N} is positively invariant under ψ_ϵ , for all $\epsilon < \epsilon_0$ and ϵ_0 sufficiently small. In particular, \mathcal{N} is an isolating block under ψ_ϵ .

Proof. We will extend the set $N' \subset \mathcal{H}$ to its neighborhood $\mathcal{N} \in \Lambda \times \mathbf{R}^n$, i.e. a set with a nonempty interior, in such a way that the flow ψ_ϵ on the boundary is transversal inward. This will imply that \mathcal{N} is an isolating block.

We start with the neighborhood U_1 and use the local coordinates of Lemma 6.2. Since the matrix A_1 has spectrum bounded away from zero, there is $\eta > 0$ and the set

$$K_1 := \{(u, v) \in U_1 \mid u \in N' \cap U_1, |v| \leq \eta_1\},$$

such that ψ_ϵ points inward on the part of the boundary ∂K_1 given by

$$\{(u, v) \in U_1 \mid u \in N' \cap U_1, |v| = \eta_1\}.$$

Now we need to check the other parts of the boundary. Lemma 6.5 and continuity implies that for sufficiently small η the flow ψ points inward on $\partial K_1 \cap F^{-1}(AB)$, where AB is the segment of the boundary of N in \mathbf{R}^2 , see Figure 2. Therefore ψ_ϵ for small ϵ points also inward on $\partial K_1 \cap F^{-1}(AB)$. On $\partial K_1 \cap F^{-1}(IJ)$, which is by construction a $\lambda = \text{const}$ hyperplane, the flow ψ_ϵ points inward since the map F maps \mathcal{G} to $y = 0$ line and thus $\dot{\lambda} < 0$ on $\partial K_1 \cap F^{-1}(IJ)$. Observe now that $W^u(M_{mid}) \cap \partial K_1 \neq \emptyset$ and therefore there is a neighborhood B_1 of $W^u(M_{mid}) \cap \partial K_1$ such that the vector field of (3) points outward in B_1 . The last part of the boundary ∂K_1 is the part where $M_{top} \cap \partial K_1 \neq \emptyset$. We now extend K_1 along M_{top} so that this will not be part of $\partial \mathcal{N}$. Along the branch M_{top} the equilibria are stable and there is a neighborhood of $M_{top} \cap N'$ of the form

$$\bar{K}_1 := \{(u, v) \in U \mid u \in N', |v| \leq \eta'_1\},$$

which coincides with K_1 in U_1 . Again we choose η'_1 small enough so that ψ_ϵ on the subset of $\partial \bar{K}_1$ of the form

$$\{(u, v) \in U \mid u \in N', |v| = \eta'_1\}$$

points inward. Similar observations as above show that ψ_ϵ points inward on $\partial(K_1 \cup K'_1)$ except for the set $B_1 \subset \partial K_1$.

A similar construction can be done in the neighborhood U_2 of the other bifurcation point to construct K_2 and then extend K_2 to a neighborhood \bar{K}_2 of $M_{bot} \cap N'$. Then flow ψ_ϵ points inward along the boundary $\partial(K_2 \cup K'_2)$, except a neighborhood $B_2 \subset \partial K_2$ of $W^u(M_{mid}) \cap \partial K_2$.

The last step in the construction of the set \mathcal{N} is to extend N' along the pre-images by F of the vertical connections from the turning points to the other branch of S .

Take the set $B_1 \subset K_1$ and flow it forward by the flow ψ . Observe that B_1 is a neighborhood of a collection of orbits for which the omega-limit set lies in M_{top} and $M_{top} \subset \bar{K}_2$. By choosing η smaller, if necessary, we can assure that $\psi(x, t(x)) \in \text{int} \bar{K}_2$ for all $x \in B_1$ and some $t(x)$, which depends on x . The flow ψ between B_1 and the arrival in \bar{K}_2 is a parallelizable flow. Take \bar{B}_1 a neighborhood of the set B_1 and set

$$\bar{X} := \bigcup_{x \in \bar{B}_1, t \in [0, t(x)]} \psi(t, x), \quad X := \bigcup_{x \in B_1, t \in [0, t(x)]} \psi(t, x).$$

We shave the set \bar{X} in the way indicated in Figure 5 (b) in such a way that the flow ψ points inward along its boundary. The same property then holds for ψ_ϵ for small ϵ .

We call this set K'_1 and construct an analogous set K'_2 by flowing the exit set B_2 of K_2 until it enters \bar{K}_1 . Set

$$\mathcal{N} := K_1 \cup K'_1 \cup \bar{K}_1 \cup K_2 \cup K'_2 \cup \bar{K}_2.$$

By construction the flow ψ_ϵ points inward along the boundary $\partial \mathcal{N}$. □

7 The Conley Index theory

We recall basic definitions of the Conley index theory. Recall that a set \mathcal{N} is an isolating neighborhood if $\text{Inv} \mathcal{N} \subset \text{int} \mathcal{N}$; that is, if the maximal invariant set S in N lies in the interior of \mathcal{N} . Such set S is an *isolated invariant set*.

The pair of compact sets $L \subset N$ is an *index pair* for an isolated invariant set S if

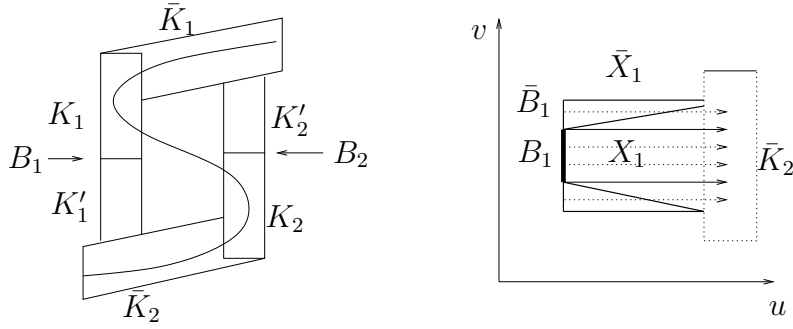

Figure 5: (a) A projection of various sets into 2-dimensional manifold $\bar{\mathcal{U}}$. (b) Shaving between flow boxes X and \bar{X} . The picture on the right is in complementary directions to the picture on the left.

1. $S = \text{Inv}(cl(N \setminus L))$ and $N \setminus L$ is a neighborhood of S ;
2. L is positively invariant in N , i.e. given $x \in L$ and $\varphi([0, t], x) \subset N$ then $\varphi([0, t], x) \subset L$;
3. L is an exit set for N , i.e. given N and $T > 0$ such that $\varphi(T, x) \notin N$, there is $t \in [0, T]$ such that $\varphi([0, t], x) \subset N$ and $\varphi(t, x) \in L$.

Observe that if N is an *isolating block* then (N, N^-) is an index pair.

The cohomological Conley index $CH(\mathcal{N})$ of an isolating neighborhood \mathcal{N} is defined as a cohomology

$$CH(\mathcal{N}) := H^*(N, L).$$

It can be shown [10], that the index is independent on the choice of the index pair and on the choice of the isolating neighborhood. In fact, it only depends on the maximal invariant set $S := \text{Inv}\mathcal{N}$ and so we use notation $CH(S)$ and talk about the Conley index of an isolated invariant set S .

Given isolating neighborhood \mathcal{N} and the flow φ , we say that Σ is a Poincaré section for φ in \mathcal{N} if $\Sigma \cap N$ is closed and for every $x \in N$

$$\varphi(x, (0, \infty)) \cap \Sigma \neq \emptyset.$$

Now we are ready to recall a theorem relating Conley index of \mathcal{N} to the existence of a periodic orbit in \mathcal{N} .

Theorem 7.1 [26, Theorem 1.3] *Assume X is an absolute neighborhood retract and $\Psi : X \times [0, \infty) \rightarrow X$ is a semi-flow with compact attraction. If N is an isolating neighborhood for ψ which admits a Poincaré section Σ and either*

$$\dim CH^{2n}(N, \Psi) = \dim CH^{2n+1}(N, \Psi) \quad \text{for } n \in \mathbb{Z}$$

or

$$\dim CH^{2n}(N, \Psi) = \dim CH^{2n-1}(N, \Psi) \quad \text{for } n \in \mathbb{Z}$$

where not all the above dimensions are zero, then Ψ has a periodic trajectory in N .

8 Proof of Theorem 3.1

We apply the Theorem 7.1 to the neighborhood $\mathcal{N} \in \Lambda \times \mathbf{R}^n$ and the flow $\Psi := \psi_\epsilon$ for sufficiently small ϵ . First we observe that $\Lambda \times \mathbf{R}^n$ is an absolute neighborhood retract and all flows ψ_ϵ are trivially semi-flows with compact attraction.

Next we verify that \mathcal{N} admits a Poincaré section. We start with the set B_1 defined in Lemma 6.6. All trajectories starting at B_1 must enter the set \bar{K}_2 in finite time. Since $\dot{\lambda} > 0$ in \bar{K}_2 and the flow on the boundary of \mathcal{N} points inward, these solutions have to enter K_2 in finite time. In K_2 we still have $\dot{\lambda} > 0$, so there are no invariant set in K_2 . Since B_2 is the exit set of K_2 , all the trajectories entering K_2 have to leave through B_2 in finite time. Therefore all trajectories starting at B_1 arrive at B_2 in finite time. A symmetric argument starting at B_2 finishes the proof that B_1 is a Poincaré section of \mathcal{N} .

We can make a cohomology calculation for the flow (12). Since N is an annulus in the plane

$$H^*(N) = \begin{cases} Z & \text{for } * = 0, 1 \\ 0 & \text{otherwise.} \end{cases}$$

Now we compute the Conley index of \mathcal{N} . By Lemma 6.6 \mathcal{N} is an isolating block and the flow on the boundary is inward. It follows that (\mathcal{N}, \emptyset) is an index pair. Therefore

$$CH^*(\mathcal{N}) = H^*(\mathcal{N}, \emptyset).$$

By construction of \mathcal{N} this set is a topological product of the set N' and a small $n - 1$ dimensional disc D^{n-1} in the v -directions. Therefore

$$H^*(\mathcal{N}, \emptyset) = H^*(\mathcal{N}) = H^*(N' \times D^{n-1}) = H^*(N') = H^*(F^{-1}(N)).$$

Finally, since F is a homeomorphism we have

$$H^*(F^{-1}(N)) = H^*(N).$$

Therefore $CH^*(\mathcal{N}) = H^*(N)$ and the Conley index satisfies the index assumptions of Theorem 7.1. Since \mathcal{N} admits a Poincaré section, Theorem 7.1 implies existence of a periodic orbit in \mathcal{N} for all sufficiently small ϵ . \square

9 An application

In this section we apply Theorem 3.1 to a well-known model of mitogen-activated protein kinase (MAPK) cascades in eukaryotic cells ([18, 6, 7, 5]), and specifically in *Xenopus* oocytes. All enzymatic reactions are considered fast, and hence a quasi-steady state approximation allows them to be modelled by Michaelis-Menten expressions for reaction rates, as functions of protein substrate concentrations. (For a similar model, but using negative feedback rather than positive feedback, see [25].) MEK is assumed to activate p42 MAPK by a nonprocessive, dual phosphorylation mechanism, so (see for instance [5]) we suppose there are three main MAPK species: unphosphorylated MAPK (z_1), MAPK-YP (z_2), and MAPK-YP/TP (z_3).

Dephosphorylations are assumed to occur in separate steps, as indicated from experiments in *Xenopus* oocytes and extracts ([32]). Similarly, there are three forms of MEK (y_1, y_2, y_3). Activation of Mos (concentration of active Mos is indicated by x) is known to be a function of many regulatory processes. As in [5], we assume that the amount of active Mos is directly stimulated by active MAPK (z_3). Such a positive feedback loop from MAPK (or from some species downstream from MAPK) into Mos is known to operate in intact oocytes ([18]).

With parameters as in [5], we obtain the following model, after eliminating y_2 and z_2 by use of stoichiometry conservation laws (total MAPK = 300, total MEK = 1200). It is five-variable system of differential equations that describes the dynamics of the cascade:

$$\begin{aligned}\dot{x} &= -\frac{V_2x}{K_2+x} + V_0z_3 + V_1 \\ \dot{y}_1 &= \frac{V_6(1200-y_1-y_3)}{K_6+(1200-y_1-y_3)} - \frac{V_3xy_1}{K_3+y_1} \\ \dot{y}_3 &= \frac{V_4x(1200-y_1-y_3)}{K_4+(1200-y_1-y_3)} - \frac{V_5y_3}{K_5+y_3} \\ \dot{z}_1 &= \frac{V_{10}(300-z_1-z_3)}{K_{10}+(300-z_1-z_3)} - \frac{V_7y_3z_1}{K_7+z_1} \\ \dot{z}_3 &= \frac{V_8y_3(300-z_1-z_3)}{K_8+(300-z_1-z_3)} - \frac{V_9z_3}{K_9+z_3},\end{aligned}$$

where $V_0 = 0.0015$, $V_1 = 0.09$, $V_2 = 1.2$, $V_3 = V_4 = 0.64$, $V_5 = V_6 = 5$, $V_7 = V_8 = 0.06$

$$V_9 = V_{10} = 5, \quad K_2 = 200, \quad K_3 = K_4 = K_5 = K_6 = 1200, \quad K_7 = K_8 = K_9 = K_{10} = 300.$$

We set the control $u := z_3$ in the first equation and let the output function $h(x, y_1, y_3, z_1, z_3) = z_3$. Therefore the variable feedback will be applied in the first equation which will change to

$$\dot{x} = -\frac{V_2x}{K_2+x} + \lambda V_0u + V_1.$$

The monotonicity and boundedness assumptions of Theorem 3.1 have been verified in ([5]). The input-output function $k(u) : \mathbf{R} \rightarrow \mathbf{R}$ has been computed numerically in Figure 5.C of the same paper. We will reproduce it here together with lines $z_3 = \frac{1}{\lambda}u$ for different value of the feedback parameter λ , see Figure 6.a.

The intersections of these lines with the graph of the input-output function $k(u)$ are the equilibria of (5) in Figure 6.b. These equilibria satisfy the rest of the assumptions of Theorem 3.1, except genericity. Since the function $k(u)$ is computed numerically and thus represents an approximation of the true input-output function, we can justifiably assume genericity of k . To construct the function q in (3) we choose $u_0 = 150$. By Theorem 3.1 the function q then has the form

$$q(x, y_1, y_3, z_1, z_3, \lambda) = \lambda(z_3 - 150).$$

We do not have biological justification for this adaptation law. We pick it in order to illustrate our theorem. However, the rate of synthesis of Mos could well be regulated by yet undiscovered feedback loops.

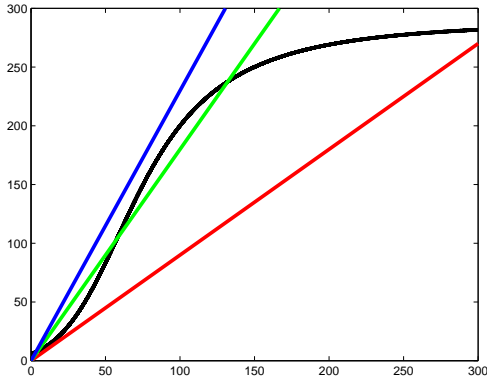

(a)

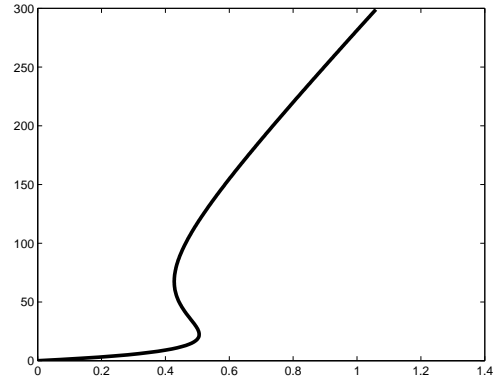

(b)

Figure 6: (a) The graph of the function $k(u)$ and lines with slopes 0.9, 1.8 and 2.3; (b) The set of equilibria of the system 5 as a function of λ . These are the intersections of the graph of $k(u)$ and the lines $\frac{1}{\lambda}u$.

With such q and $\epsilon = 0.000005$, the projections of solutions starting at four different initial conditions into the λ, z_3 plane is in the Figure 7.a. The time evolution of the variable y_3 for the same four initial conditions are shown in Figure 7.b. The matching colors in these two figures correspond to the same initial condition. These solutions converge to a periodic orbit predicted by Theorem 3.1.

References

- [1] D. Angeli and E.D. Sontag, Monotone control systems, *IEEE Trans. Automatic Control*, vol. 48, No. 10, pp. 1684-1698, (2003)
- [2] D. Angeli and E.D. Sontag, Multi-stability in monotone input/output systems, *Systems & Control Letters* **51**, 185-202, (2004).
- [3] D. Angeli and E.D. Sontag, An analysis of a circadian model using the small-gain approach to monotone systems, *Proc. IEEE Conf. Decision and Control, Paradise Island, Bahamas, Dec. 2004*, IEEE Publications, 2004, pp. 575–578.
- [4] D. Angeli, P. De Leenheer and E.D. Sontag, A small-gain theorem for almost global convergence of monotone systems, *Systems and Control Letters* **52**, 407–414, (2004).
- [5] D. Angeli, J.E. Ferrell Jr. and E. Sontag, Detection of multistability, bifurcations, and hysteresis in a large class of biological positive-feedback systems, *Proc. Natl. Acad. Sci.* vol. 101, no. 7, 1822-1827, (2004).
- [6] C.P. Bagowski and J.E. Ferrell Jr., Bistability in the JNK cascade, *Curr. Biol.* **11**, 1176-1182, (2001).

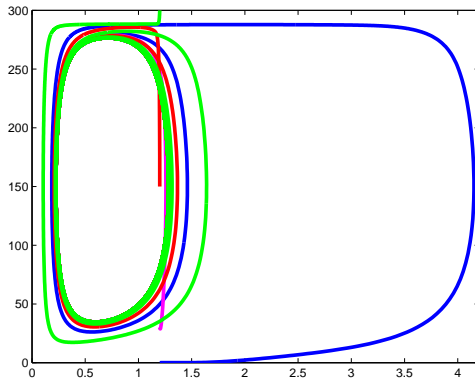

(a)

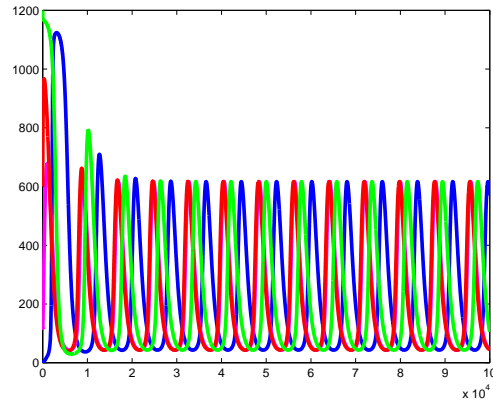

(b)

Figure 7: (a) Projections of solutions into λ, z_3 plane and (b) the y_3 as a function of time, for four different initial conditions. The matching colors in these two figures correspond to the same initial condition.

- [7] U.S. Bhalla, P.T. Ram, and R. Iyengar, MAP kinase phosphatase as a locus of flexibility in a mitogen-activated protein kinase signalling network, *Science* **297**, 1018-1023, (2002).
- [8] E. Boczko, T.G. Cooper, T. Gedeon, K. Mischaikow, D. Murdock, S. Pratap and S. Wells, Structure theorems and the dynamics of nitrogen catabolite repression in yeast, *Proc. Natl. Acad. Sci.* **102**, 5647-5652, (2005).
- [9] P. Brunovsky, Controlling nonuniqueness of local invariant manifolds, *Comenius University Preprint M6-91*, (1991)
- [10] C. Conley, *Isolated Invariant sets in Compact Metric Spaces*, CBMS Reg. Conf. Series in Math., 38, AMS, Providence 1978.
- [11] F.R. Cross, V. Archambault, M. Miller and M. Klovstad, Testing a mathematical model of the yeast cell cycle, *Mol.Biol.Cell* **13**, 52-70, (2002).
- [12] P. De Leenheer, D. Angeli, and E.D. Sontag, On predator-prey systems and small-gain theorems, *J. Mathematical Biosciences and Engineering* **2**, 25-42, (2005).
- [13] P. De Leenheer, M. Malisoff, A small-gain theorem for monotone systems with multi-valued input-state characteristics, submitted.
- [14] M.B. Elowitz and S. Leibler, A synthetic oscillatory network of transcriptional regulators, *Nature* **403** 335-338, (2000).
- [15] G. Enciso and E.D. Sontag, Monotone systems under positive feedback: Multi-stability and a reduction theorem, *Systems and Control Letters* **54** 159-168, (2005).
- [16] G. Enciso and E.D. Sontag, Global attractivity, I/O monotone small-gain theorems, and biological delay systems, *Discrete and Continuous Dynamical Systems*, in press.

- [17] G. Enciso, H.L. Smith and E.D. Sontag, Non-monotone systems decomposable into monotone systems with negative feedback, *J. Diff. Equations*, in press.
- [18] J.E. Ferrell and E.M. Machleder, The biochemical basis of an all-or-none cell fate switch in *Xenopus* oocytes, *Science* **280**, 895-898, 1998.
- [19] M. Golubitskii and D. Schaeffer, *Singularities and Groups in Bifurcation Theory*, Springer-Verlag 1984.
- [20] J. Hale, *Ordinary Differential Equations*, John Wiley & Sons Inc., 2nd edition, 1980.
- [21] P. Hartman, *Ordinary Differential Equations*, Wiley 1964.
- [22] C.K.R.T. Jones, *A geometric approach to applied dynamics and differential equations*, Lecture Notes 1996.
- [23] S. Lefschetz, *Differential Equations: Geometric Theory*, Dover 1977.
- [24] A. Katok and B. Hasselblatt, *Introduction to the Modern Theory of Dynamical Systems* Cambridge University Press 1995.
- [25] B.N. Kholodenko, Negative feedback and ultrasensitivity can bring about oscillations in the mitogen-activated protein kinase cascades, *Eur. J. Biochem.* **267**, 1583-1588, 2000.
- [26] Ch. McCord, K. Mischaikow and M. Mrozek, Zeta functions, periodic trajectories, and the Conley index, *J. Diff. Eq.*, **121** (1995), 258-292.
- [27] Novick, A. and Wiener, M., Enzyme induction as an all-or-none phenomena, *Proc. Natl. Acad. Sci.* **43**, 553-566, 1957.
- [28] J.R. Pomerening, E.D. Sontag, and J.R. Ferrell Jr., Building a cell cycle oscillator: hysteresis and bistability in the activation of Cdc2, *Nat. Cell Biol.* **5**, 346-351, (2003).
- [29] M. Ptashne, *A Genetic Switch: Phage and Higher Organisms*, Blackwell, Oxford, 1992.
- [30] W. Sha, J. Moore, K. Chen, Y.D. Lassaletta, C.S. Yi, J.J. Tyson, and I.C. Sible, Hysteresis drives cell-cycle transitions in *Xenopus Laevis* egg extracts, *Proc. Natl. Acad. Sci.* **100**, 975-980, (2002).
- [31] H. Smith, *Monotone Dynamical Systems*, AMS Mathematical Surveys and Monographs 41, 1995.
- [32] M.L. Sohaskey and J.E. Ferrell, Jr., Distinct, constitutively active MAPK phosphatases function in *Xenopus* oocytes: implications for p42 MAPK regulation in vivo, *Mol. Biol. Cell* **10**, 3729-3743, 1999.
- [33] E.D. Sontag, Some new directions in control theory inspired by systems biology, *IEEE Systems Biology* **1**, 9-18 (2004).